

Extreme 220GHz+Broadband Silicon Capacitor X2SC 0201M 22nF BV11



Rev. 2.05

General description

X2SC Capacitor targets Optical communication system such as ROSA/TOSA, SONET and all optoelectronics as well as High speed data system or products. The X2SC is suitable for DC blocking, feedback, coupling and bypassing applications in all broadband optoelectronics and High-speed data system. The unique technology of integrated passive device in silicon, developed by Murata Integrated Passive Solutions, offers unique performances with low insertion loss, low reflection and phase stability from 73 KHz to 220 GHz.

These capacitors in ultra-deep trenches in silicon have been developed in a semiconductor process, in order to integrate trench MOS capacitor providing high capacitance value of 22 nF (for kHz–MHz range) and high frequency MIM capacitors for low capacitance value for GHz range), combined in a 0201M [0.6x0.3mm] case.

The X2SC capacitor provides very high stability of the capacitance over temperature, voltage variation as well as a very high reliability.

X2SC capacitors have an extended operating temperature ranging from -55 to 150°C, with very low capacitance change over temperature.

Assembly: Suitable for surface mounted application on rigid PCB, ceramic substrate, FR4 (laminated) or flex platforms.

Bump finishing: SAC305 type 6 for pre-bumped version or ENIG for un-bumped version. Copper pads optional for embedding version, as an optional finishing.

Key features

- Ultra-Broadband performance up to 220 GHz
- Resonance free
- Phase stability
- Insertion loss < 1dB Typ. up to 140 GHz
- Ultra-high stability of capacitance value:
 - Temperature 70ppm/K (-55 °C to +150 °C)
 - Voltage <-0.1%/Volt
 - Negligible capacitance loss through ageing
- Low profile: 140 μm including bump height (SAC305 40μm bumps after reflow)
- Break down voltage : 11V
- Low leakage current < 100pA
- High reliability
- High operating temperature (up to 150 °C)
- Compatible with high temperature cycling during manufacturing operations (exceeding 300 °C)
- Compatible with EIA 01005 footprint and with EIA 0201 outline

Key applications

- ROSA/TOSA
- SONET
- High speed digital logic
- Microwave/millimetre system
- High volumetric efficiency (*i.e. capacitance per unit volume*)
- Broadband test equipment



Functional diagram

The next figure provides implementation set-up diagram.

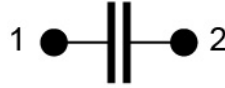

Figure 1 Block Diagram

Electrical performances

Symbol	Parameter	Conditions	Min.	Typ.	Max.	Unit
C	Capacitance value	@+25°C	-	22	-	nF
ΔC_P	Capacitance tolerance ⁽¹⁾	@+25°C	-15	-	+15	%
T _{OP}	Operating temperature		-55	20	150	°C
T _{STG}	Storage temperature ⁽²⁾		-70	-	165	°C
ΔC_T	Capacitance temperature variation	-55 °C to 150 °C	-	70	-	ppm/K
V _{DC}	Operating voltage ⁽³⁾		-	-	3.8 ⁽⁴⁾ 3.4 ⁽⁵⁾	V _{DC}
BV	Break down voltage	@+25°C	11	-	-	V
ΔC_{RVDC}	Capacitance voltage variation	From 0 V to RV _{DC} , @+25°C	-	-	-0.1	%/V _{DC}
IR	Insulation resistor	@RV _{DC} , +25°C, 120s	-	10	-	GΩ
Fc-3dB	Cut-off frequency at 3dB	@+25°C	-	73	86	kHz
IL	Insertion loss ⁽⁶⁾	@ 20 GHz, +25°C	-	0.2	-	dB
		@ 40 GHz, +25°C	-	0.3	-	dB
		@ 60 GHz, +25°C	-	0.4	-	dB
		@ 80 GHz, +25°C	-	0.5	-	dB
		@ 100 GHz, +25°C	-	0.6	-	dB
		@ 150 GHz, +25°C	-	0.8	-	dB
		@ 220 GHz, +25°C	-	2.5	-	dB
RL	Return loss ⁽⁶⁾	Up to 140 GHz, +25°C	10	-	-	dB
ESD	HBM stress ⁽⁷⁾	JS-001-2017	2	-	-	kV

Table 1 - Electrical performances

⁽¹⁾: other tolerance available upon request.

⁽²⁾: without packaging.

⁽³⁾: Lifetime is voltage and temperature dependent, please refer to application note 'Lifetime of 3D capacitors'.

⁽⁴⁾: 10 years of intrinsic life time prediction at 100°C continuous operation.

⁽⁵⁾: 10 years of intrinsic life time prediction at 150°C continuous operation.

⁽⁶⁾: simulation, to be optimized.

⁽⁷⁾: please refer to application note 'ESD Challenge in 3D Murata Integrated Passive technology'.

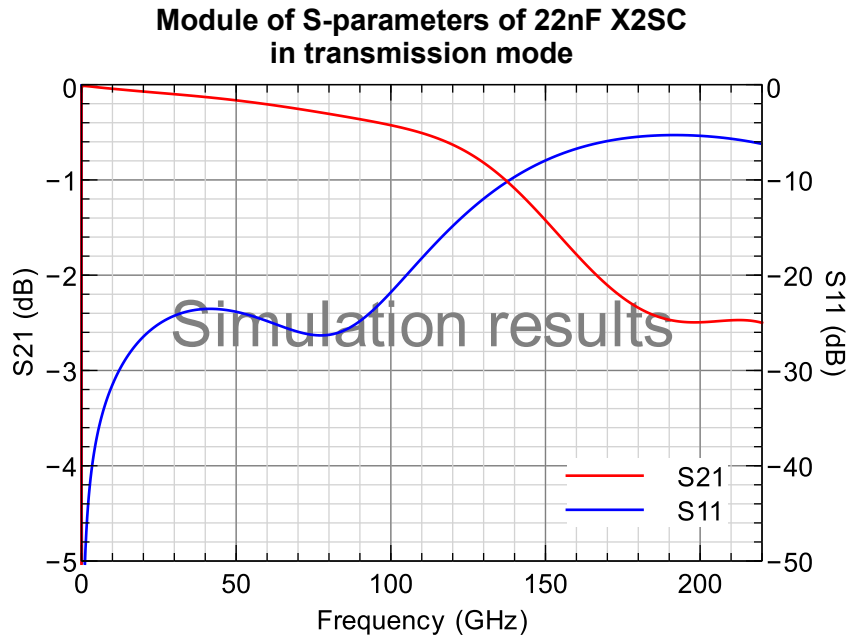
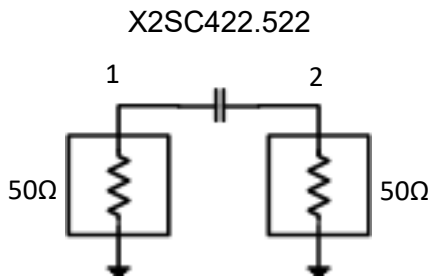

Figure 2 - 22nF X2SC simulated results
(module of S-parameters)

**Schematic of 22nF X2SC
in transmission mode**



10-mil thick Quartz substrate

coplanar waveguide (CPW) - line width = 0.180mm and gap = 0.20mm (nominal
50 Ohm characteristic impedance)

Figure 3 - 22nF X2SC measurement schematic

Example of 0201M surface mounted

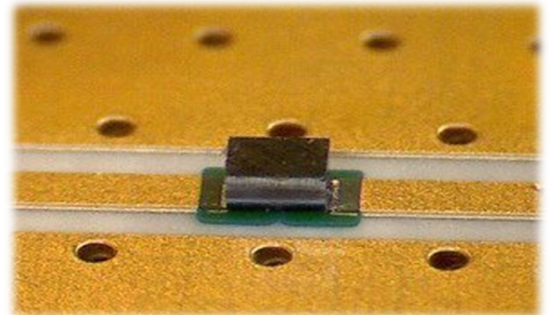

Figure 4 – micro picture of X2SC mounted on board
in coplanar mode



Pinning definition

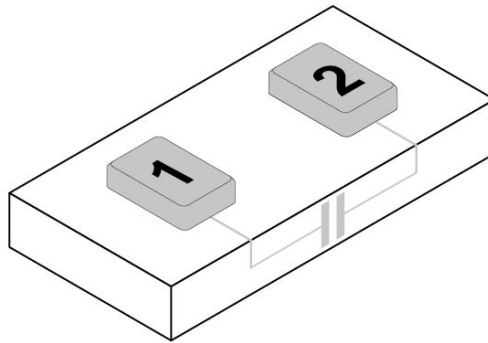

Figure 5 Pin configuration

pin #	Symbol	Coordinates X / Y
1	Signal	-150.0 / 0.0
2	Signal	150.0 / 0.0

Table 2 - Pining description. Reference (0,0) located at the centre of the die.

Ordering Information for X2SC422.522

Type number	Package		
	Packaging ⁽¹⁾	Finishing	Description
939120422522-T3S	7" T&R (1 000 pieces/reel) ^{(3) (5)}	SAC ⁽²⁾	X2SC 0201M - 22nF – 2 pads – 0.6 x 0.3 x 0.10 mm ⁽⁴⁾
939120422522-T5S	7" T&R (5 000 pieces/reel) ^{(3) (6)}	SAC ⁽²⁾	X2SC 0201M - 22nF – 2 pads – 0.6 x 0.3 x 0.10 mm ⁽⁴⁾
939120422522-T3N	7" T&R (1 000 pieces/reel) ^{(3) (5)}	ENIG ⁽²⁾	X2SC 0201M - 22nF – 2 pads – 0.6 x 0.3 x 0.10 mm ⁽⁴⁾
939120422522-T5N	7" T&R (5 000 pieces/reel) ^{(3) (6)}	ENIG ⁽²⁾	X2SC 0201M - 22nF – 2 pads – 0.6 x 0.3 x 0.10 mm ⁽⁴⁾

(1) Other Film Frame Carrier are possible on request

(2) SAC = ENIG (0.1µm Au / 5µm Ni) + SAC305 type 6 or ENIG 0.1µm Au / 5µm Ni

(3) Missing capacitors can reach 0.5%

(4) Refer to **Erreur ! Source du renvoi introuvable.**

(5) Dedicated for Pre-Production

(6) For all demands including Mass Production

Table 3 - Packaging and ordering information

Product Name	Die Name	Description
X2SC422.522	XQM0201522	X2SC 22nF/0201M/BV11 – 2 pads – 0.6 x 0.3 x 0.10 mm

Table 4 - Die information



Pad Metallization

The Surface Mounted Capacitor is delivered as standard with SAC305 type6 bumping or ENIG (0.1µm Au / 5µm Ni).

Other Metallization, such as Copper, Thick Gold or Aluminum pads are possible on request.

Silicon dies are not sensitive to humidity, please refer to applications notes 'Assembly Notes' section 'Handling precautions and storage'.

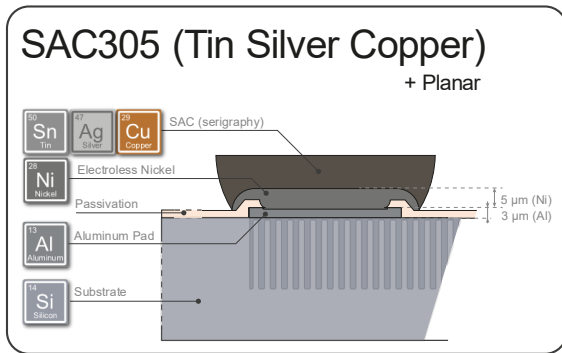

Figure 6 – Top electrode description of SAC305 pre-bumped version

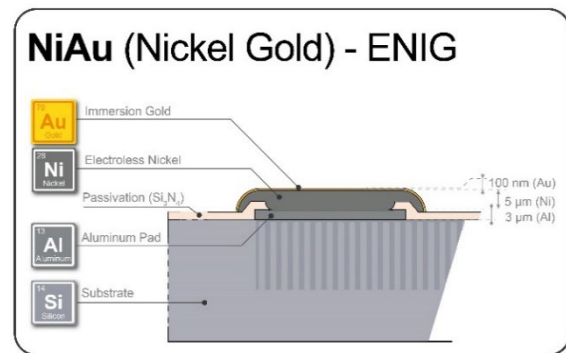

Figure 7 – Top electrode description of ENIG finishing version

Material regulation

This product is RoHS compliant at the time of publication. For further information about regulation compliancy, please ask your sales representative.



Package outline

The product is delivered as a bare silicon die.

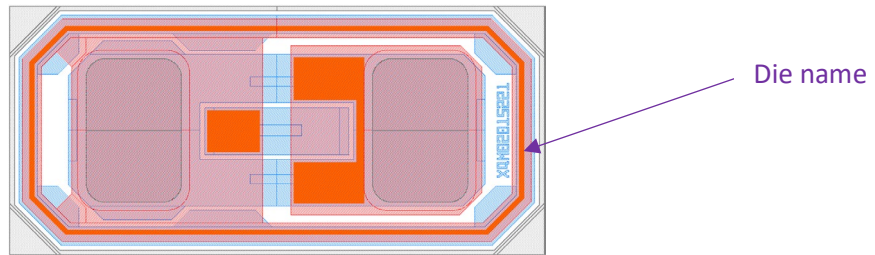

Figure 8 – Layout view

	L (mm)	W (mm)	T (mm)	c (mm)	p (mm)	e (mm)	t (mm)
Component dimension	0.60 ±0.02	0.30 ±0.02	0.11 max	0.10	0.20	0.15	0.04 ⁽¹⁾ 0.05 ⁽²⁾ 0.005 ⁽³⁾
Landing pad recommendation	/	/	/	0.114 min	0.186 max	0.164 min	/

- (1) Solder joint height after reflow on board.
- (2) Solder bump height before assembly
- (3) only with ENIG on optional version

Table 5 - Dimensions and tolerances

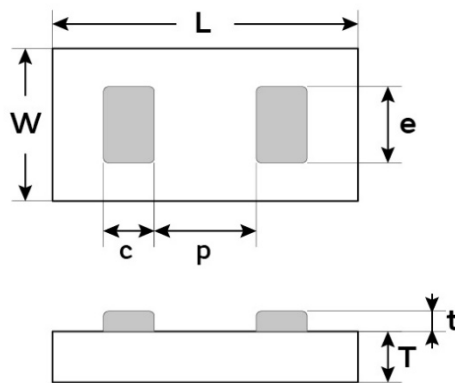

Figure 9 - Package outline drawing

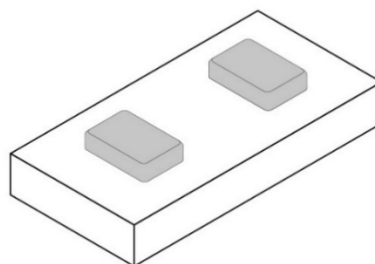

Figure 10 - Package isometric view



Assembly

X2SC series is compatible with standard reflow technology.

It is recommended to design mirror pads on the PCB.

For further information, please see our mounting application note.

The attachment techniques recommended by Murata on the customer's substrates are fully detailed in specific documents available on our website. To assure the correct use and proper functioning of Murata capacitors **please download the assembly instructions on <https://www.murata.com/en-us/products/capacitor/siliconcapacitors> and read them carefully.**



Figure 11 Scan this QR Code to access the Murata Silicon Capacitor web page

Extreme 220GHz+Broadband Silicon Capacitor X2SC 0201M 22nF BV11



Rev. 2.05

Packaging format

Please refer to application note 'Products Storage Conditions and Shelf Life'.

Tape and Reel: Dies are flipped in the tape cavity (bump down) with die ID located near the driving holes of the tape.

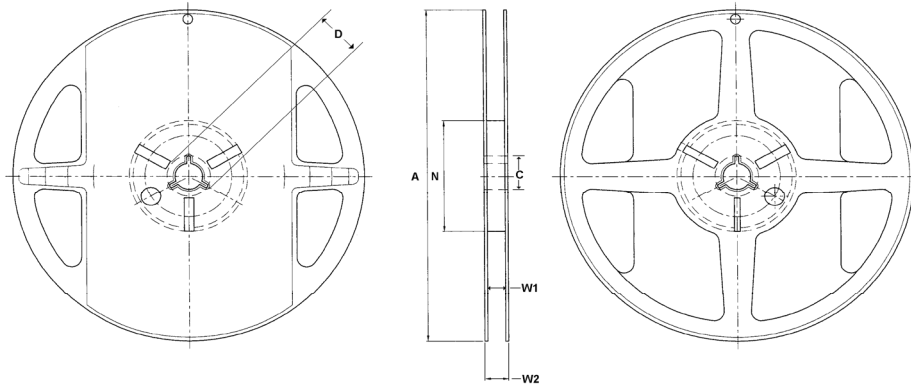

Figure 12 - Reel drawing

Tape Width	Diameter A	C	D	Hub N	W1	W2
8	178 (7 inches)	13.5	21	60	9.5	11.4

Table 6 - Reel dimensions (mm)

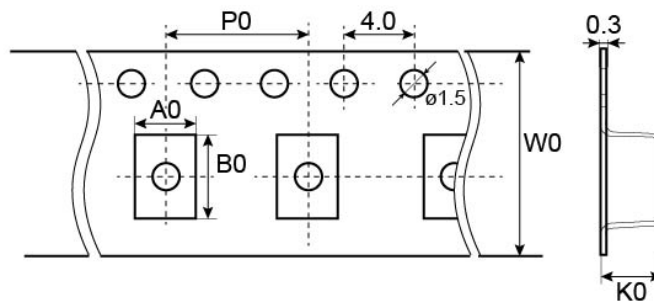

Figure 13 - Tape drawing

Cavity dimensions			Carrier tape width W0	Carrier tape pitch P0	Reel Capacity
Ao	Bo	Ko			
0.37 ± 0.04	0.67 ± 0.04	0.20 ± 0.04	8.00	2.00	5000 or 1000

Table 7 - Tape dimensions (mm)



Definitions

Data sheet status

Objective specification: This data sheet contains target or goal specifications for product development.

Preliminary specification: This data sheet contains preliminary data; supplementary data may be published later.

Product specification: This data sheet contains final product specifications.

Limiting values

Stress above one or more of the limiting values may cause permanent damage to the device. These are stress ratings only and operation of the device at these or any other conditions above those given in the Electrical performances sections of this specification is not implied. Exposure to limiting values for extended periods may affect device reliability.

Application information

Where application information is given, it is advisory and does not form part of the specification.

Revision history

Revision	Date	Description	Author
Release 0.01	2021 July 15 th	Creation	OGA
Release 0.04	2022 April 25 th	Update of expander grip ring view	OGA
Release 1.01	2022 Sept 23 th	Only both SPQ 1K & 5Kpcs	OGA
Release 2.01	2023 Feb 28 th	Only T&R format	OGA
Release 2.02	2023 Oct 31 th	Packaging update	DYE, OGA
Release 2.03	2025 Jan 15 th	Complementary land pattern information	MOK+ DYE + OGA
Release 2.04	2025 Sep 24 th	Small update	MOY+ DYE + OGA
Release 2.05	2025 Oct 21 st	Ordering information has been updated according to the latest product lineup and specification.	CGU, HFU

Disclaimer / Life support applications

These products are not designed for use in life support appliances, devices, or systems where malfunction of these products can reasonably be expected to result in personal injury. Murata customers using or selling these products for use in such applications do so at their own risk and agree to fully indemnify Murata for any damages resulting from such improper use or sale.

Reproduction in whole or in part is prohibited without the prior written consent of the copyright owner. The information presented in this document does not form part of any quotation or contract, is believed to be accurate and reliable and may be changed without notice. No liability will be accepted by the publisher for any consequence of its use. Publication thereof does not convey nor imply any license under patent or other industrial or intellectual property rights.

Murata Integrated Passive Solutions S.A. makes no representation that the use of its products in the circuits described herein, or the use of other technical information contained herein, will not infringe upon existing or future patent rights. The descriptions contained herein do not imply the granting of licenses to make, use, or sell equipment constructed in accordance therewith. Specifications are subject to change without notice.



www.murata.com

mis@murata.com