

Broadband Silicon Capacitor BBSC

0201M 5.6nF BV30



REV. 3.00

General description

BBSC Capacitor targets Optical communication system such as ROSA/TOSA, SONET and all optoelectronics as well as High speed data system or products.

The BBSC is suitable for DC blocking, feedback, coupling and bypassing applications in all broadband optoelectronics and High-speed data system.

The unique technology of integrated passive device in silicon, developed by Murata Integrated Passive Solutions, offers unique performances with low insertion loss, low reflection and phase stability from 287 KHz to 40 GHz.

These capacitors in ultra-deep trenches in silicon have been developed in a semiconductor process, in order to integrate trench MOS capacitor providing high capacitance value of 5.6nF (for kHz–MHz range) and MIM capacitors for low capacitance value (for GHz range), both in a SMT 0201M (0.6 x 0.3mm). The BBSC capacitor provides very high stability of the capacitance over temperature, voltage variation as well as a very high reliability.

BBSC capacitors have an extended operating temperature ranging from -55 to 150°C, with very low capacitance change over temperature (+70ppm/K).

Assembly: flip chip applications through existing laminated packages or rigid PCB, ceramic substrate, FR4 or flex platforms suitable.

Bump finishing: SAC305 type 6.

Copper pads optional for embedding version and ENIG for un-bumped version, as an optional finishing.

Key features

- Ultra-Broadband performance to 40 GHz
- Resonance free
- Phase stability
- Insertion loss < 0.4dB Typ. up to 40 GHz
- Ultra-high stability of capacitance value:
 - Temperature 70ppm/K (-55 °C to +150 °C)
 - Voltage <-0.1%/Volt
 - Negligible capacitance loss through ageing
- Low profile: 140µm including bump height
- Break down voltage : 30V
- Low leakage current < 100pA
- High reliability
- High operating temperature (up to 150 °C)
- Compatible with high temperature cycling during manufacturing operations (exceeding 300 °C)
- Compatible with EIA 0201 footprint
- SAC305 40µm bumps after reflow

Key applications

- ROSA/TOSA
- SONET
- High speed digital logic
- Microwave/millimetre system
- High volumetric efficiency (i.e. *capacitance per unit volume*)
- Broadband test equipment



Functional diagram

The next figure provides implementation set-up diagram.

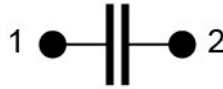

Figure 1 Block Diagram

Electrical performances

Symbol	Parameter	Conditions	Min.	Typ.	Max.	Unit
C	Capacitance value	@+25°C	-	5.6	-	nF
ΔC_P	Capacitance tolerance ⁽¹⁾	@+25°C	-15	-	+15	%
T _{OP}	Operating temperature		-55	20	150	°C
T _{STG}	Storage temperature ⁽²⁾		-70	-	165	°C
ΔC_T	Capacitance temperature variation	-55 °C to 150 °C	-	70	-	ppm/K
RV _{DC}	Rated voltage ⁽³⁾		-	-	16 ⁽⁴⁾ 13.6 ⁽⁵⁾	V _{DC}
BV	Break down voltage	@+25°C	30	-	-	V
ΔC_{RVDC}	Capacitance voltage variation	From 0 V to RV _{DC} , @+25°C	-	-	-0.1	%/V _{DC}
IR	Insulation resistor	@RV _{DC} , +25°C, 120s	-	10	-	GΩ
ESR	Equivalent Serial Resistance	@ +25°C, shunt mode	-	1.4	-	Ohm
ESL	Equivalent Serial Inductance	@ +25°C, SRF shunt mode	-	100	-	pH
Fc-3dB	Cut-off frequency at 3dB	@+25°C	-	287	334	kHz
IL		@ 20 GHz, +25°C	-	0.2	-	dB
		@ 40 GHz, +25°C	-	0.4	-	dB
RL	Return loss	Up to 40 GHz, +25°C	19	-	-	dB
ESD	HBM stress ⁽⁶⁾	JS-001-2017	8	-	-	kV

Table 1 - Electrical performances

(1): other tolerance available upon request

(2): without packaging.

(3): Lifetime is voltage and temperature dependent, please refer to application note 'Lifetime of 3D capacitors'

(4): 10 years of intrinsic life time prediction at 100°C continuous operation

(5): 10 years of intrinsic life time prediction at 150°C continuous operation

(6): please refer to application note 'ESD Challenge in 3D Murata Integrated Passive technology'

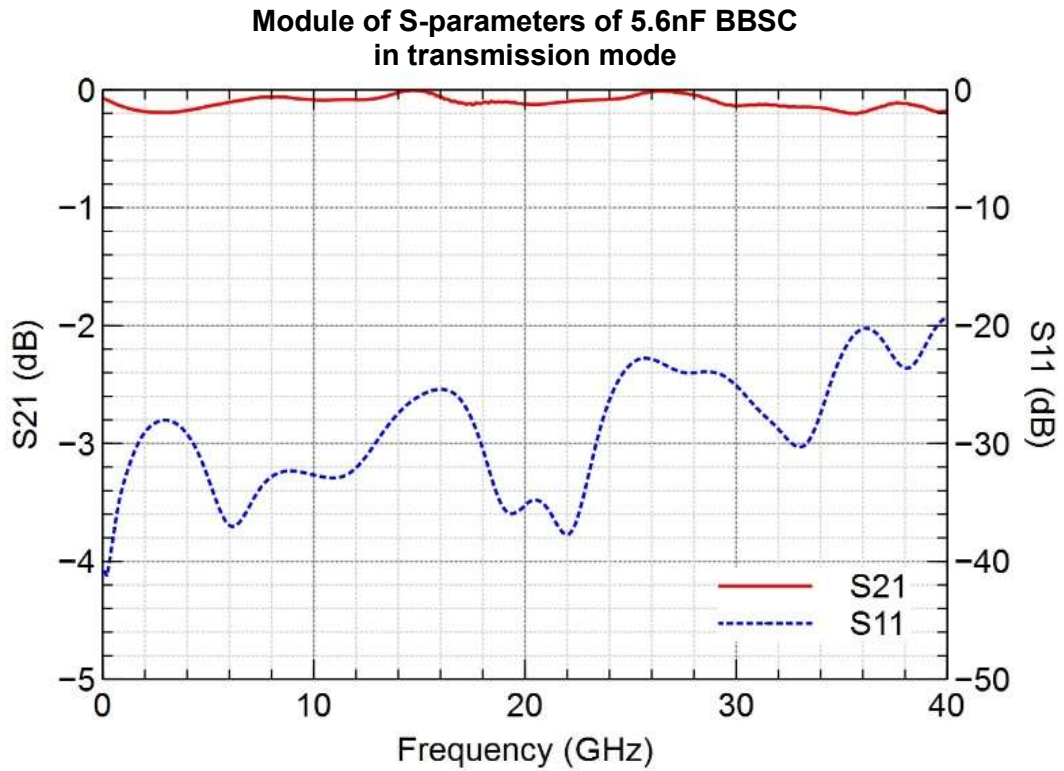
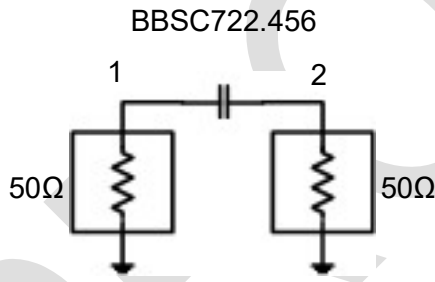

Figure 2 – 5.6nF BBSC measurement results (module of S-parameters)

Schematic of 5.6nF BBSC in transmission mode



4-mil Rogers 4350B.

Microstrip mode – line width = 0.200mm and gap = 0.200 mm. (nominal 50 ohm characteristic impedance).

Figure 3 – 5.6nF BBSC measurement schematic

Example of 0201M surface mounted

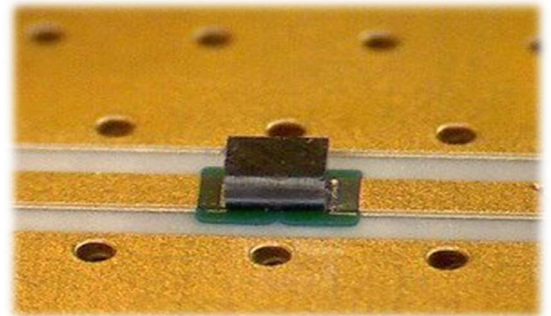

Figure 4 – micro picture of BBSC mounted on board in coplanar mode



Pinning definition

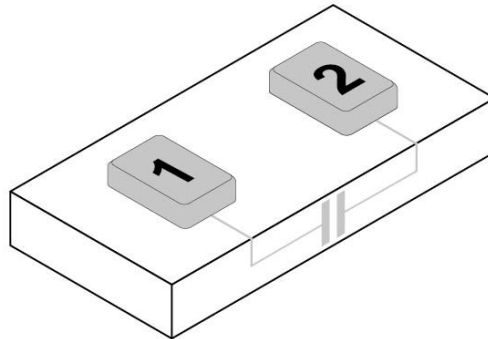

Figure 5 Pinning definition

pin #	Symbol	Coordinates X / Y
1	Signal	-150.0 / 0.0
2	Signal	150.0 / 0.0

Table 2 - Pinning description. Reference (0,0) located at the center of the die.

Ordering Information

Murata Integrated Passive Devices delivers products with AQL level II (0.65). Tighter quality levels are available upon request.

Part number	Package		
	Packaging	Finishing	Description
939114722456-F1S	6" film frame carrier ⁽¹⁾	SAC ⁽²⁾	BBSC 0201M – 5.6nF – 2 pads – 0.60mm x 0.30mm x 0.10mm ⁽⁴⁾
939114722456-T3S	7" T&R with 1Kpieces / reel ⁽³⁾	SAC ⁽²⁾	BBSC 0201M – 5.6nF – 2 pads – 0.60mm x 0.30mm x 0.10mm ⁽⁴⁾
939114722456-T5S	7" T&R with 5Kpieces / reel ⁽³⁾	SAC ⁽²⁾	BBSC 0201M – 5.6nF – 2 pads – 0.60mm x 0.30mm x 0.10mm ⁽⁴⁾
939114722456-T3N	7" T&R with 1Kpieces / reel ⁽³⁾	ENIG ⁽²⁾	BBSC 0201M – 5.6nF – 2 pads – 0.60mm x 0.30mm x 0.10mm ⁽⁴⁾

- (1) Other Film Frame Carrier are possible on request
- (2) SAC = ENIG + SAC305 type 6 or ENIG = 0.1µm Au / 5µm Ni
- (3) missing capacitors can reach 0.5%
- (4) Refer to Figure 7

Table 3 - Packaging and ordering information

Product Name	Die Name	Description
BBSC722.456	XJM0201456	BBSC 5.6nF/0201M/BV30 – 2 pads – 0.6 x 0.3 x 0.10 mm

Table 4 - Die information



Pad Metallization

The Surface Mounted Capacitor is delivered as standard with SAC305 type6 bumping.

Other Metallization, such as ENIG (0.1µm Au / 5µm Ni), Copper, Thick Gold or Aluminum pads are possible on request.

Silicon dies are not sensitive to humidity, please refer to applications notes ‘Assembly Notes’ section ‘Handling precautions and storage’.

Material regulation

This product is RoHS compliant at the time of publication. For further information about regulation compliancy, please ask your sales representative.

Package outline

The product is delivered as a bare silicon die.

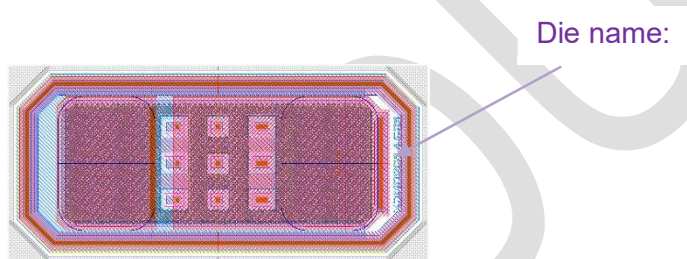

Figure 6 - Layout view

L (mm)	W (mm)	T (mm)	c (mm)	p (mm)	e (mm)	t (mm)
0.60 ±0.02	0.30 ±0.02	0.10 ±0.01	0.10	0.20	0.15	0.04 ⁽¹⁾ 0.05 ⁽²⁾ 0.005 ⁽³⁾

(1) Standard with solder joint height after reflow on board.
 (2) Standard with solder bump height before assembly
 (3) only in case of ENIG finishing

Table 5 - Dimensions and tolerances

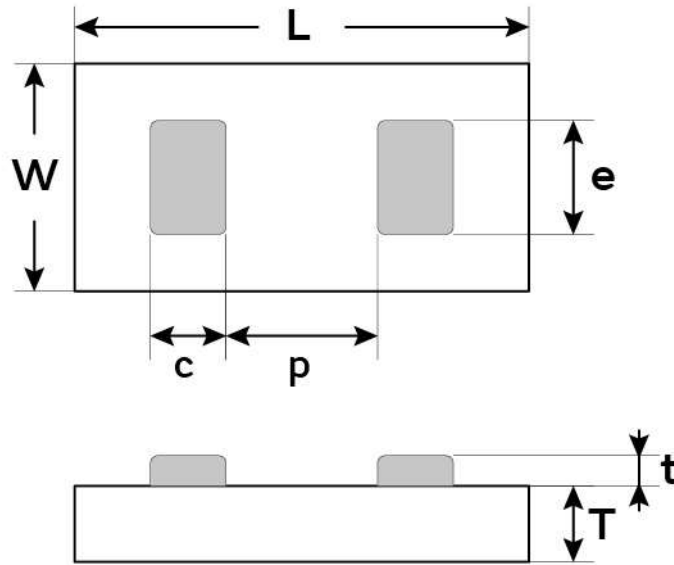

Figure 7 - Package outline drawing

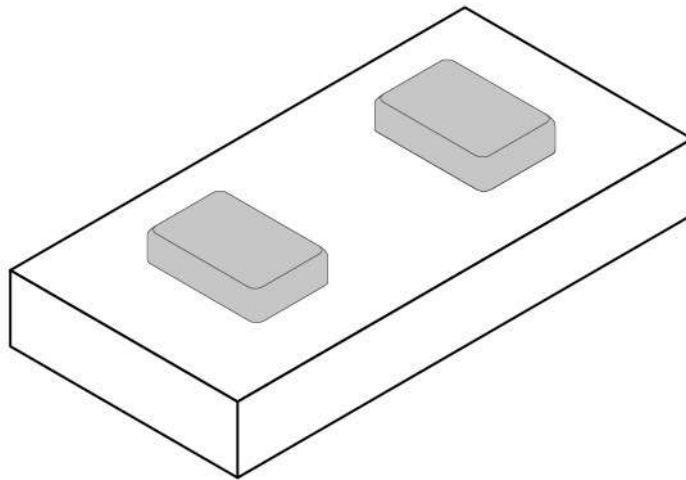

Figure 8 Isometric view



Assembly

BBSC series is compatible with standard reflow technology.

It is recommended to design mirror pads on the PCB.

For further information, please see our mounting application note

The attachment techniques recommended by Murata on the customer's substrates are fully detailed in specific documents available on our website. To assure the correct use and proper functioning of Murata capacitors **please download the assembly instructions on <https://www.murata.com/en-us/products/capacitor/siliconcapacitors> and read them carefully.**



Figure 9 Scan this QR Code to access the Murata Silicon Capacitor web page



Packaging format

Please refer to application note 'Products Storage Conditions and Shelf Life'.

Tape and Reel: Dies are flipped in the tape cavity (bump down) with die ID located near the driving holes of the tape.

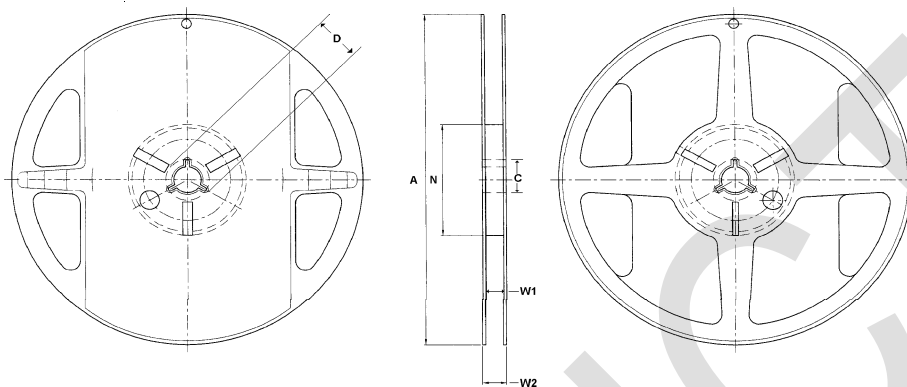

Figure 10 - Reel drawing

Tape Width	Diameter A	C	D	Hub N	W1	W2
8	178 (7 inches)	13.5	21	60	9.5	11.4

Table 6 - Reel dimensions (mm)

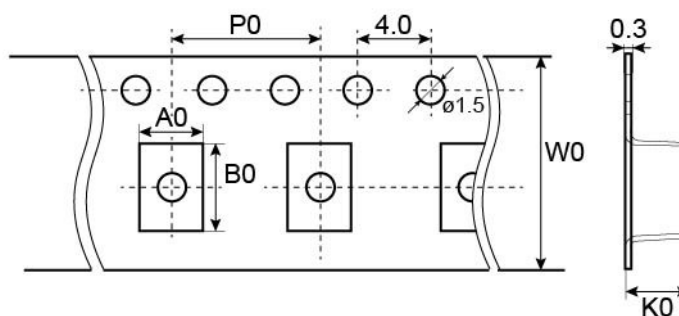

Figure 11 - Tape drawing

Cavity dimensions			Carrier tape width W0	Carrier tape pitch P0	Reel Capacity
Ao (*)	Bo (*)	Ko (*)			
0.37 +/-0.04	0.67 +/-0.04	0.20 +/-0.04	8.00	2.00	1000 or 5000

Table 7 - Tape dimensions (mm)



Film frame carrier:

With UV curable dicing tape (UV performed)

Good dies are identified using the SINF electronic mapping format. No ink is added on wafer to label other dies.

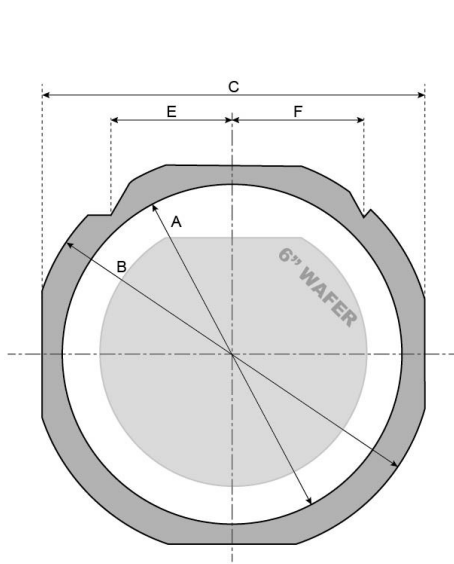

Figure 12 FF070 Frame with a 6" wafer

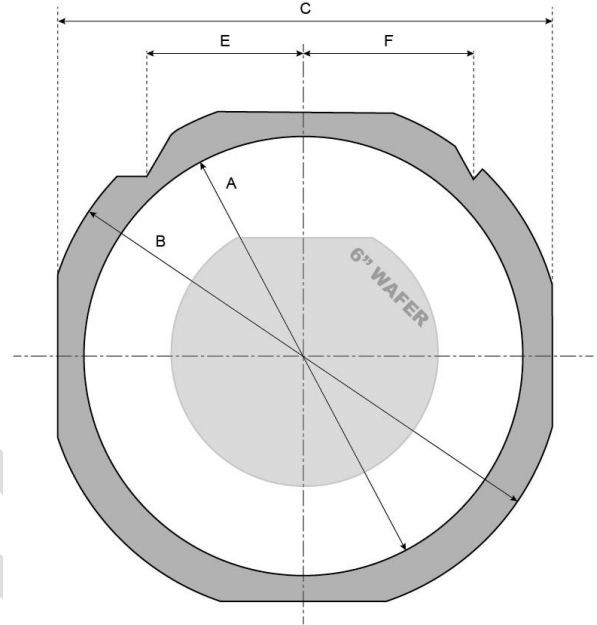

Figure 13 FF108 Frame with a 6" wafer

Frame Reference	Frame Style	Inside diameter A	Outside diameter B	Width C	Thickness	Pin location E	Pin location F
FF070 ⁽¹⁾	DTF-2-6-1	7.638"	8.976"	8.346"	0.048"	2.370"	2.5"
FF108 ⁽¹⁾	DTF-2-8-1	9.842"	11.653"	10.866"	0.048"	2.381"	2.5"

Table 8 - Frame dimensions (inches)

(1) or equivalent



Expander grip ring 6" diameter:

With UV curable dicing tape (UV performed)

Good dies are identified using the SINF electronic mapping format. No ink is added on wafer to label other dies.

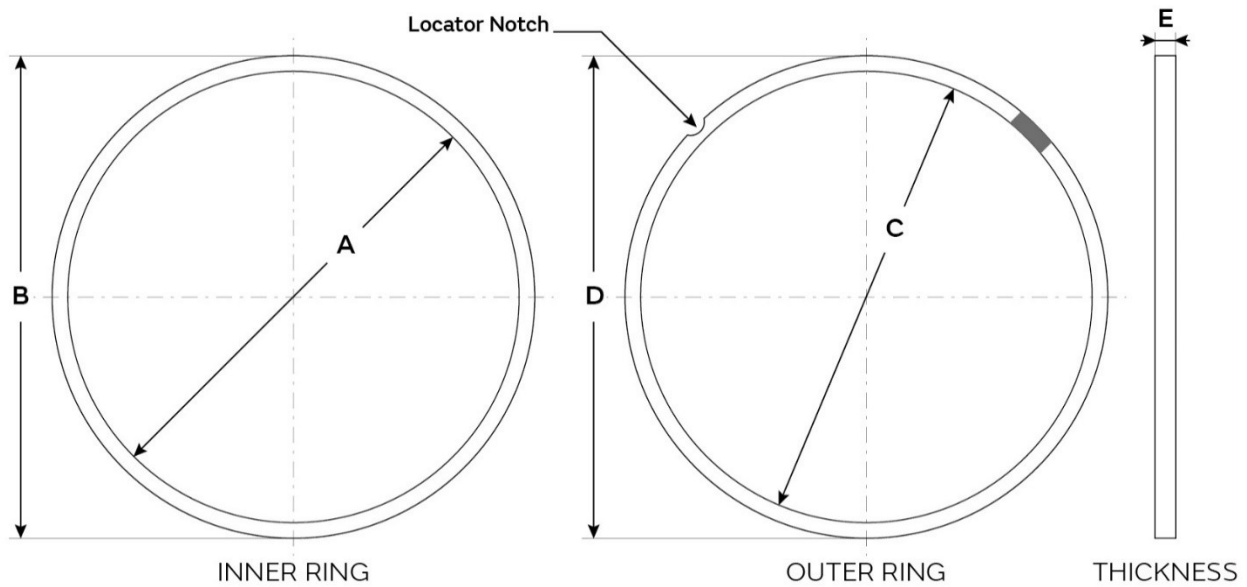

Figure 14 – Grip Ring drawing

Grip Ring Style	A	B	C	D	E	Locator Notch
GRP-2620-6 ⁽¹⁾	7.670"	7.973"	7.975"	8.280"	0.236"	None

Table 9 - Frame dimensions (inches)

(1) or equivalent



Definitions

Data sheet status

Objective specification: This data sheet contains target or goal specifications for product development.

Preliminary specification: This data sheet contains preliminary data; supplementary data may be published later.

Product specification: This data sheet contains final product specifications.

Limiting values

Stress above one or more of the limiting values may cause permanent damage to the device. These are stress ratings only and operation of the device at these or any other conditions above those given in the Electrical performances sections of this specification is not implied. Exposure to limiting values for extended periods may affect device reliability.

Application information

Where application information is given, it is advisory and does not form part of the specification.

Revision history

Revision	Date	Description	Author
Release 1.00	2016 Feb.18th	Objective specification	OGA
Release 1.10	2020 Sept. 18th	Packaging update	OGA, SCA
Release 3.00	2021 April 12th	Added 5kppieces T&R packaging (T5S)	SCA; OGA

Disclaimer / Life support applications

These products are not designed for use in life support appliances, devices, or systems where malfunction of these products can reasonably be expected to result in personal injury. Murata customers using or selling these products for use in such applications do so at their own risk and agree to fully indemnify Murata for any damages resulting from such improper use or sale.

Reproduction in whole or in part is prohibited without the prior written consent of the copyright owner. The information presented in this document does not form part of any quotation or contract, is believed to be accurate and reliable and may be changed without notice. No liability will be accepted by the publisher for any consequence of its use. Publication thereof does not convey nor imply any license under patent or other industrial or intellectual property rights.

Murata Integrated Passive Solutions S.A. makes no representation that the use of its products in the circuits described herein, or the use of other technical information contained herein, will not infringe upon existing or future patent rights. The descriptions contained herein do not imply the granting of licenses to make, use, or sell equipment constructed in accordance therewith. Specifications are subject to change without notice.



www.murata.com

mis@murata.com