

Type 1WL-857 LoRa + Wi-Fi[®] + Bluetooth[®] + GNSS Module Rev. B

Semtech LR1110 Chipset for LoRa, Wi-Fi Scan, GNSS Scan
STMicro STM32WB55 Chipset for MCU and Bluetooth LE

- Design Name: Type 1WL-857
- P/N: LBEU5ZZ1WL-857



Table of Contents

1 Scope	6
2 Features & Benefits	6
2.1 Features.....	6
2.2 Benefits.....	6
3 Ordering Information	7
4 Block Diagram	8
5 Certification Information	9
5.1 Radio Certification.....	9
5.2 Bluetooth Qualification	9
6 Dimensions, Markings and Terminal Configurations	10
7 Module Pin Descriptions	11
7.1 Pin Assignments	11
7.2 Pin Descriptions	12
7.3 Configuration Pins.....	14
8 Absolute Maximum Ratings	14
9 Operating Conditions	15
9.1 Operating Conditions	15
9.2 Digital I/O Requirements	15
9.3 Package Thermal Conditions	15
10 Power Sequence	16
10.1 Power-On Sequence.....	16
10.2 Power-Off Sequence.....	16
11 Interface Specification.....	17
11.1 USB Specifications.....	17
11.2 LPUART Specifications	18
11.3 I2C Specifications	18
11.4 SPI Specifications	19
11.5 SWD Specifications.....	19
12 DC/RF Characteristics	19
12.1 Sleep Current.....	20
12.2 DC/RF Characteristics for Sub-GHz.....	20
12.3 DC/RF Characteristics for Wi-Fi Passive Scanner.....	21
12.4 DC/RF Characteristics for Bluetooth Low Energy.....	22
12.4.1 1 Mbps PHY Condition	22
12.4.2 2 Mbps PHY Condition	23

12.5 DC/RF Characteristics for GNSS	25
12.5.1 LR1110 GNSS Scanner Receiver Specification.....	25
13 Land Pattern	25
14 Reference Circuit	27
15 General Regulatory Certification for LBEU5ZZ1WL	28
15.1 Application Model Part Number.....	28
15.2 Marking.....	28
15.3 Certification Label.....	28
15.4 Country of Origin	29
16 Radio Regulatory Certification by Country for LBEU5ZZ1WL.....	30
16.1 JRL	30
16.1.1 Power Level for Japan.....	30
16.1.2 About Notations.....	30
16.2 FCC	31
16.2.1 Power Level for FCC	31
16.2.2 Information to Include in the User Manual	31
16.3 ISED	32
16.3.1 Information to Display on Host Device and User Manual	32
16.3.2 Power Level for ISED	32
16.4 Europe	33
16.4.1 Power Level for Europe	33
17 Tape and Reel Packing.....	34
17.1 Dimensions of Tape (Plastic Tape).....	34
17.2 Dimensions of Reel.....	35
17.3 Taping Diagrams.....	36
17.4 Leader and Tail Tape	37
17.5 Packaging (Humidity Proof Packing)	38
18 Notice	38
18.1 Storage Conditions.....	38
18.2 Handling Conditions	39
18.3 Standard PCB Design (Land Pattern and Dimensions)	39
18.4 Notice for Chip Placer	40
18.5 Soldering Conditions	40
18.6 Cleaning.....	40
18.7 Operational Environment Conditions	41
18.8 Input Power Capacity	41
19 Preconditions to Use Our Products	42

Revision History.....	44
-----------------------	----

Figures

Figure 1: Block Diagram	8
Figure 2: Dimensions, Markings, and Terminal Configurations	10
Figure 3: Pin Assignments (Top View).....	11
Figure 4: Package Thermal Conditions	16
Figure 5: Power-On Sequence Graph.....	16
Figure 6: Power-Off Sequence Graph.....	17
Figure 7: Burst current definition	20
Figure 8: Land Pattern	26
Figure 9: Reference Circuit	27
Figure 10: Marking Information	28
Figure 11: Certification Label (Humidity proof Packing).....	28
Figure 12: Certification Label Example.....	29
Figure 13: Dimensions of Tape (Plastic tape)	34
Figure 14: Dimensions of Reel (Unit: mm)	35
Figure 15: Taping Diagrams.....	36
Figure 16: Leader and Tail Tape.....	37
Figure 17: Peeling Force.....	37
Figure 18: Humidity Proof Packaging.....	38
Figure 19: Reflow soldering standard conditions (Example).....	40

Tables

Table 1: Document Conventions.....	5
Table 2: Ordering Information	7
Table 3: Transmit Power Limit	9
Table 4: Markings	10
Table 5: Dimensions	10
Table 6: Terminal Configurations	12
Table 7: Pin Descriptions	12
Table 8: Boot modes configuration.....	14
Table 9: Absolute and Maximum Ratings.....	14
Table 10: Operating Conditions	15
Table 11: Digital I/O Characteristics.....	15
Table 12: Parameters for Power-On Sequence Graph.....	16
Table 13: Parameters for Power-Off Sequence Graph.....	17
Table 14: USB electrical characteristics.....	17

Table 15: I2C Implementation	18
Table 16: I2C analog filter characteristic	18
Table 17: DC/RF Characteristics and Files	19
Table 18: Sleep Current Specifications	20
Table 19: Sub-GHz Bands Specifications	20
Table 20: Wi-Fi Passive Scanner Specifications	21
Table 21: BLE 1 Mbps PHY Specifications	22
Table 22: BLE 2 Mbps PHY Specifications	23
Table 23: LR1110 GNSS Scanner Receiver Specifications	25
Table 24: Japan Maximum Radio Frequency Power - All Mode	30
Table 25: FCC Maximum Radio Frequency Power - All Mode	31
Table 26: ISED Maximum Radio Frequency Power - All Mode	33
Table 27: Europe Maximum Radio Frequency Power - All Mode	33
Table 28: Taping Specifications	36

About This Document

Murata's Type 1WL-857 is a small and high-performance module based on Semtech LR1110 + STMicro STM32WB55, supporting LoRa + IEEE 802.11 b/g/n Wi-Fi Passive Scanner + Bluetooth 5.2 LE + GNSS. This datasheet describes the Type 1WL-857 module in detail.



Please be aware that an important notice concerning availability, standard warranty and use in critical applications of Murata products and disclaimers thereto appears at the end of this specification sheet.









Audience & Purpose

Intended audience includes any customer looking to integrate this module into their product, specifically RF, hardware, software, and system engineers.

Document Conventions

Table 1 describes the document conventions.

Table 1: Document Conventions

Conventions	Description
	Warning Note Indicates very important note. Users are strongly recommended to review.
	Info Note Intended for informational purposes. Users should review.
	Menu Reference Indicates menu navigation instructions. Example: Insert → Tables → Quick Tables → Save Selection to Gallery 
	External Hyperlink This symbol indicates a hyperlink to an external document or website. Example: Embedded Artists AB  Click on the text to open the external link.
	Internal Hyperlink This symbol indicates a hyperlink within the document. Example: Scope  Click on the text to open the link.
<code>Console input/output or code snippet</code>	Console I/O or Code Snippet This text Style denotes console input/output or a code snippet.
<code># Console I/O comment // Code snippet comment</code>	Console I/O or Code Snippet Comment This text Style denotes a console input/output or code snippet comment. <ul style="list-style-type: none"> • Console I/O comment (preceded by "#") is for informational purposes only and does not denote actual console input/output. • Code Snippet comment (preceded by "//") may exist in the original code.

1 Scope

This specification applies to the Geolocation module for LoRa + Wi-Fi + Bluetooth LE + GNSS.

2 Features & Benefits

2.1 Features

- ◆ STM32WB55 wireless microcontroller
 - Cortex-M4, RAM: 256KB, Flash: 1MB
 - Bluetooth Low Energy transceiver
- ◆ SEMTECH LR1110 RF IC
 - LoRa Transceiver
 - Wi-Fi Passive Scanner
 - Multi-Constellation GNSS Scanner (GPS & BeiDou)
- ◆ Low power consumption
- ◆ TCXO for maximum frequency accuracy
- ◆ Structure: Metal case + PCB
- ◆ Weight: 980 mg
- ◆ MSL: 3
- ◆ LGA surface-mount type
- ◆ RoHS compliant

Product name	LBEU5ZZ1WL-857
Technology	LoRa, Bluetooth LE, Wi-Fi Scanner, GNSS
Peripheral I/F	UART, USB, SPI, I2C, ADC, GPIOs
Dimensions	17.50 x 17.00 x 2.15 mm (max)
Operating Temperature	- 30 °C to 85 °C
Regulatory certification	FCC, ISED, CE, JRL

2.2 Benefits

- Open MCU design for the user's application code
- Small/highly integrated Geolocation module available in the market
- Allows simple RF design with minimum additional components required

- Simplifies host product's PCB design as fewer layers are required
- Single solution for both indoor & outdoor Geolocation use cases
- The module's RF certification can facilitate the host product certification
- Quick time to market solution
- Build/develop applications with the extensive STMicro tools

3 Ordering Information

Table 2 shows the ordering information for the Type 1WL-857 module.

Table 2: Ordering Information

Ordering Part Number	Description
LBEU5ZZ1WL-857	Module order
LBEU5ZZ1WL-857SMP	Sample module order (If module samples are not available through distribution, contact Murata referencing this part number)
LBEU5ZZ1WL-857EVB	Type 1WL-857 EVB

4 Block Diagram

The Type 1WL-857 block diagram is presented in **Figure 1**.

Figure 1: Block Diagram

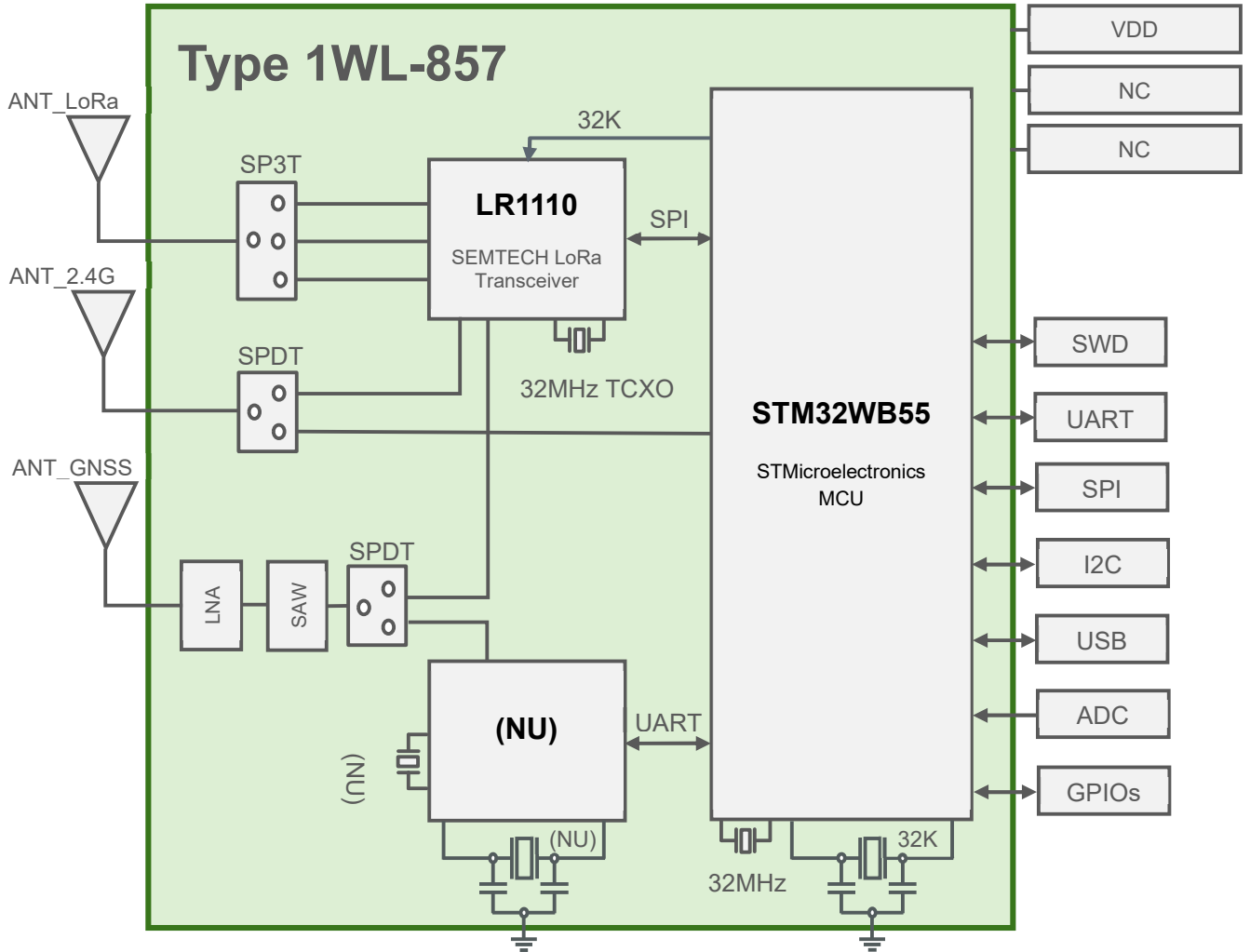

5 Certification Information

This section has information about radio and Bluetooth certification.

5.1 Radio Certification

Table 3 shows the transmit power required for each region.

Table 3: Transmit Power Limit

Country	ID	Tx Power Limit
USA (FCC)	VPYLB1WL	LoRa: 22dBm setting; BLE: max power (setting 31)
Canada (ISED)	772C-LB1WL	LoRa: 22dBm setting; BLE: max power (setting 31)
Europe	EN 300328 V2.2.2, EN 300220-2 V3.2.1, EN 303413 V1.2.1 test reports are prepared.	LoRa: 14dBm setting; BLE: max power (setting 31)
Japan	Certificate of Construction Type based on Japanese Radio Law. [R] 218-220026	LoRa: 13dBm setting; BLE: max power (setting 31)

5.2 Bluetooth Qualification

- QDID: 202884
- Set Bluetooth Tx Power to Class 1.5.
- For PICS for supported Bluetooth functions refer to [Bluetooth SIG site](#) .

6 Dimensions, Markings and Terminal Configurations

This section has information on dimensions, marking, and terminal configurations for Type 1WL-857.

Figure 2: Dimensions, Markings, and Terminal Configurations

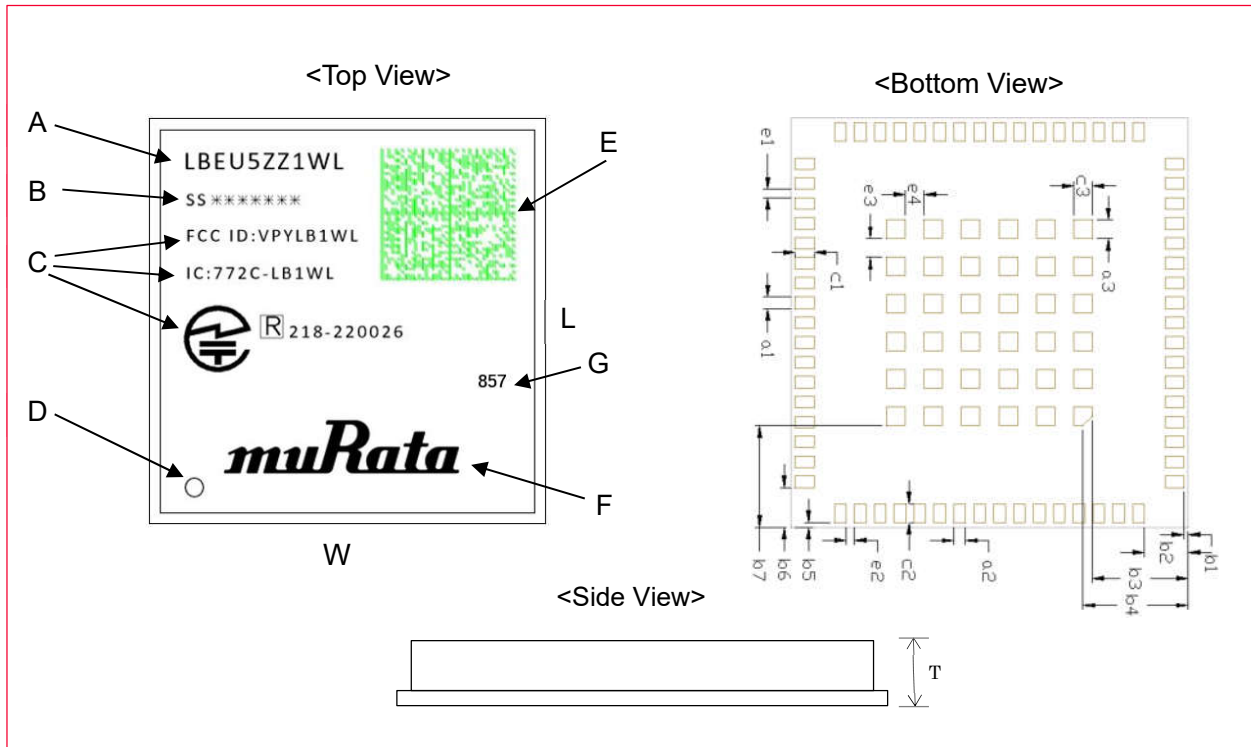

Table 4: Markings

Marking	Meaning
A	Module Type
B	Production Process Number
C	Certification ID
D	Pin 1 Marking
E	2D code
F	Murata Logo
G	Type number

Table 5: Dimensions

Mark	Dimensions (mm)	Mark	Dimensions (mm)	Mark	Dimensions (mm)	Mark	Dimensions (mm)
L	17.5 ± 0.1	W	17.0 ± 0.1	T	2.15 max	a1	0.5 ± 0.1
a2	0.5 ± 0.1	a3	0.8 ± 0.1	b1	0.2 ± 0.1	b2	1.875 ± 0.1
b3	4.3 ± 0.1	b4	4.5 ± 0.1	b5	0.2 ± 0.1	b6	1.7 ± 0.1
b7	4.35 ± 0.1	c1	0.8 ± 0.1	c2	0.8 ± 0.1	c3	0.8 ± 0.1
e1	0.35 ± 0.1	e2	0.35 ± 0.1	e3	0.8 ± 0.1	e4	0.8 ± 0.1

7 Module Pin Descriptions

This section has the Pin descriptions of Type 1WL-857 and pin assignments layout descriptions.

7.1 Pin Assignments

The pin assignment layout (Top View) is shown in **Figure 3**.

Figure 3: Pin Assignments (Top View)

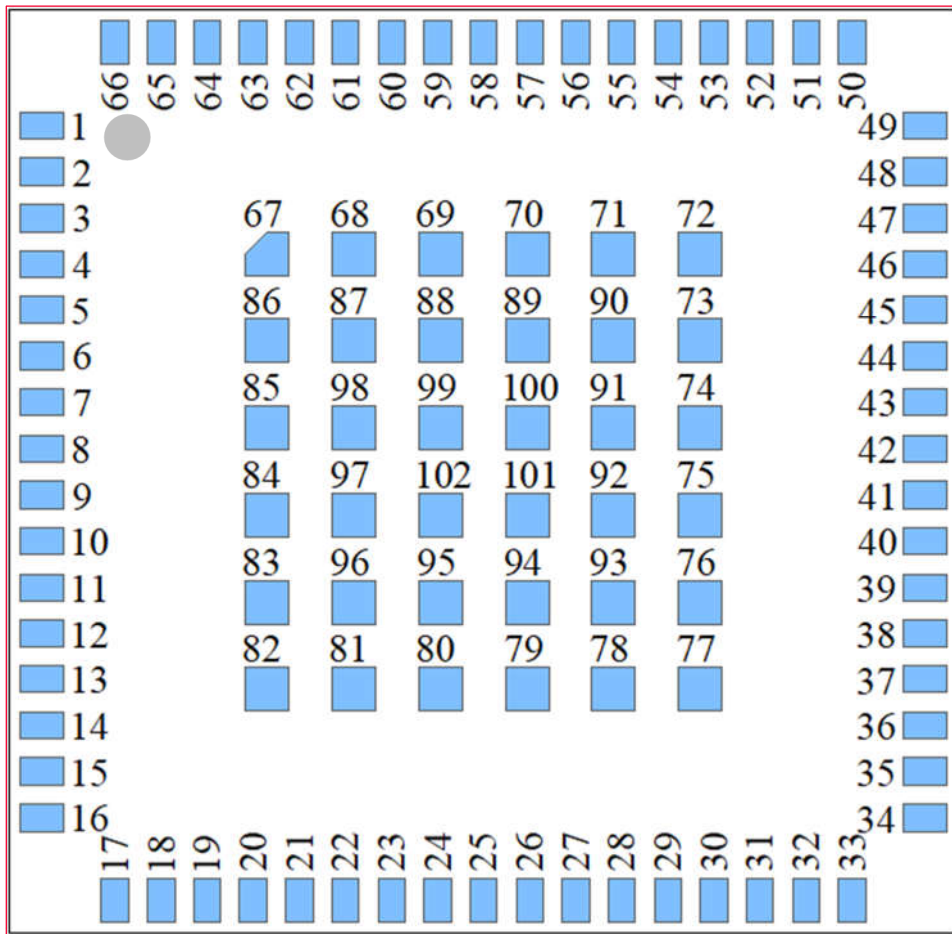

Table 6 illustrates the terminal configurations.

Table 6: Terminal Configurations

No.	Terminal Name	No.	Terminal Name	No.	Terminal Name
1	GND	29	GPIO4	57	LPUART_RTS
2	NRST_MCU	30	NC	58	PWM_CTRL
3	I2C_INT1	31	GND	59	GPIO8
4	I2C_SCL	32	NC	60	GPIO9
5	I2C_SDA	33	GND	61	LPUART_TX
6	I2C_POWER	34	GND	62	LPUART_RX
7	GPIO1	35	GPIO11	63	USR_ADC
8	BOOT0	36	GPIO12	64	GPIO10
9	GND	37	GND	65	I2C_INT2
10	ANT_2G4	38	USART_RX	66	GND
11	GND	39	USART_TX	67-102	GND
12	GPIO2	40	GPIO13		
13	SWDIO	41	GPIO14		
14	SWCLK	42	GND		
15	SWO	43	GND		
16	GND	44	ANT_GNSS		
17	GND	45	GND		
18	GND	46	VBAT_SENSE		
19	VDD	47	GPIO5		
20	VDD	48	LPUART_CTS		
21	GND	49	GND		
22	GPIO3	50	GND		
23	USB_DP	51	NRST_LORA		
24	USB_DM	52	GND		
25	SPI_CS	53	ANT_LORA		
26	SPI_MOSI	54	GND		
27	SPI_MISO	55	GPIO6		
28	SPI_SCK	56	GPIO7		

7.2 Pin Descriptions

Table 7 describes Type 1WL-857 Pins.

Table 7: Pin Descriptions

No.	Pin name	Type	Connection to IC Pin Name	Description
1	GND	GND	-	Ground
2	NRST_MCU	I	STM32: NRST	STM32 reset signal, active low
3	I2C_INT1	I/O	STM32: PC2	Interrupt for I2C sensor
4	I2C_SCL	I/O	STM32: PB8	I2C clock
5	I2C_SDA	I/O	STM32: PB7	I2C data
6	I2C_POWER	I/O	STM32: PB9	Power for I2C sensor
7	GPIO1	I/O	STM32: PD14	General purpose I/O
8	BOOT0	I	STM32: PH3-BOOT0	STM32 BOOT0 pin. At start up, BOOT0 pin and BOOT1 option bit are used to select three boot option (section 7.3).
9	GND	GND	-	Ground

No.	Pin name	Type	Connection to IC Pin Name	Description
10	ANT_2G4	RF	-	2.4GHz antenna (BLE/ Wi-Fi)
11	GND	GND	-	Ground
12	GPIO2	I/O	STM32: PD13	General purpose I/O
13	SWDIO	I/O	STM32: PA13	SWD interface data pin
14	SWCLK	I/O	STM32: PA14	SWD interface clock pin
15	SWO	I/O	STM32: PB3	SWD interface debug pin
16	GND	GND	-	Ground
17	GND	GND	-	Ground
18	GND	GND	-	Ground
19	VDD	Power	-	Power supply for STM32 and LR1110
20	VDD	Power	-	Power supply for STM32 and LR1110
21	GND	GND	-	Ground
22	GPIO3	I/O	STM32: PD7	General purpose I/O
23	USB_DP	I/O	STM32: PA12	USB interface data positive
24	USB_DM	I/O	STM32: PA11	USB interface data minus
25	SPI_CS	I/O	STM32: PD2	SPI interface chip selection
26	SPI_MOSI	I/O	STM32: PD4	SPI interface master output slave input
27	SPI_MISO	I/O	STM32: PD3	SPI interface master input slave output
28	SPI_SCK	I/O	STM32: PD1	SPI interface clock
29	GPIO4	I/O	STM32: PD0	General purpose I/O
30	NC	NC	NC	NC
31	GND	GND	-	Ground
32	NC	NC	NC	NC
33	GND	GND	-	Ground
34	GND	GND	-	Ground
35	GPIO11	I/O	STM32: PC10	General purpose I/O
36	GPIO12	I/O	STM32: PA15	General purpose I/O
37	GND	GND	-	Ground
38	USART_RX	I/O	STM32: PA10	USART of STM32
39	USART_TX	I/O	STM32: PA9	USART of STM32
40	GPIO13	I/O	STM32: PE4	General purpose I/O
41	GPIO14	I/O	STM32: PB15	General purpose I/O
42	GND	GND	-	Ground
43	GND	GND	-	Ground
44	ANT_GNSS	RF	-	GNSS antenna
45	GND	GND	-	Ground
46	VBAT_SENSE	AI/O	STM32: PA1	Measure battery voltage
47	GPIO5	I/O	STM32: PC9	General purpose I/O
48	LPUART_CTS	I/O	STM32: PB13	LPUART of STM32
49	GND	GND	-	Ground
50	GND	GND	-	Ground
51	NRST_LORA	I	LR1110: NRESET STM32: PB5	LR1110 reset, active low. Reserved for internal usage.
52	GND	GND	-	Ground
53	ANT_LORA	RF	-	LoRa antenna
54	GND	GND	-	Ground
55	GPIO6	I/O	STM32: PD6	General purpose I/O
56	GPIO7	I/O	STM32: PD10	General purpose I/O
57	LPUART_RTS	I/O	STM32: PB12	LPUART of STM32
58	PWM_CTRL	I/O	STM32: PB6	Load control
59	GPIO8	I/O	STM32: PC4	General purpose I/O

No.	Pin name	Type	Connection to IC Pin Name	Description
60	GPIO9	I/O	STM32: PC5	General purpose I/O
61	LPUART_TX	I/O	STM32: PB11	LPUART of STM32
62	LPUART_RX	I/O	STM32: PB10	LPUART of STM32
63	USR_ADC	AI/O	STM32: PA0	Analog IO
64	GPIO10	I/O	STM32: PC11	General purpose I/O
65	I2C_INT2	I/O	STM32: PC3	Interrupt for I2C sensor
66	GND	GND	-	Ground
67-102	GND	GND	-	Ground

7.3 Configuration Pins

At start up, BOOT0 pin and BOOT1 option bit are used to select one of three boot options.

Table 8 shows the boot modes configuration for Type 1WL-857.

Table 8: Boot modes configuration

BOOT0 pin	BOOT1 option bit	BOOT modes
0	x	Boot from user flash
1	0	Boot from system memory
1	1	Boot from embedded SRAM

The STM32WB55 always boots on the Cortex-M4 core. The embedded bootloader code makes it possible to boot from various peripherals:

- USB
- UART
- I2C
- SPI

8 Absolute Maximum Ratings

The absolute maximum ratings are shown in **Table 9**.

Table 9: Absolute and Maximum Ratings

Parameter	Minimum	Maximum	Unit	
Storage Temperature	-40	+85	°C	
Supply Voltage	VDD	-0.3	3.6	V



Stresses in excess of the absolute ratings may cause permanent damage. Functional operation is not implied under these conditions. Exposure to absolute ratings for extended periods of time may adversely affect reliability. No damage assuming only one parameter is set at limit at a time with all other parameters are set within operating condition.

9 Operating Conditions

This section describes the operating conditions.

9.1 Operating Conditions

The operating conditions are shown in **Table 10**.

Table 10: Operating Conditions

Parameter	Minimum	Typical	Maximum	Unit
Operating Temperature	-30		+85	°C
Operating Voltage	VDD	2.8(1)	3.3	V

- When using USB function, the minimum VDD should be 3.0V. The STM32WB55xx USB functionality is ensured down to 2.7 V, but the full USB electrical characteristics are degraded in the 2.7 to 3.0 V voltage range.



Operation beyond the recommended operating conditions is neither recommended nor guaranteed.

9.2 Digital I/O Requirements

Table 11 shows the digital I/O characteristics of Type 1WL-857.

Table 11: Digital I/O Characteristics

Symbol	Parameter	Condition	Minimum	Typical	Maximum	Unit
V _{IH}	Input high voltage		0.7*VDD			V
V _{IL}	Input low voltage				0.3*VDD	V
V _{HYS}	Input hysteresis			200		mV
V _{OH}	Output high voltage	TTL port	2.4			V
V _{OL}	Output low voltage				0.4	V
R _{PU}	Weak pull-up equivalent resistor (1)	V _{IN} = V _{SS}	25	40	55	kΩ
R _{PD}	Weak pull-down equivalent resistor (1)	V _{IN} = V _{DDIOx}	25	40	55	kΩ
C _{IO}	I/O pin capacitance	-	-	5	-	pF

- Pull-up and pull-down resistors are designed with a true resistance in series with a switchable PMOS/NMOS. This PMOS/NMOS contribution to the series resistance is minimal (~10% order).

9.3 Package Thermal Conditions

The package thermal conditions are as below:

- **R_{ψjt}** : TBD°C/W

- $R\psi_{jt} = (T_j - T_t)/P$



T_j: Junction temperature (°C), **T_t**: Top temperature (°C), **P**: Total Power Consumption (W)

Figure 4: Package Thermal Conditions

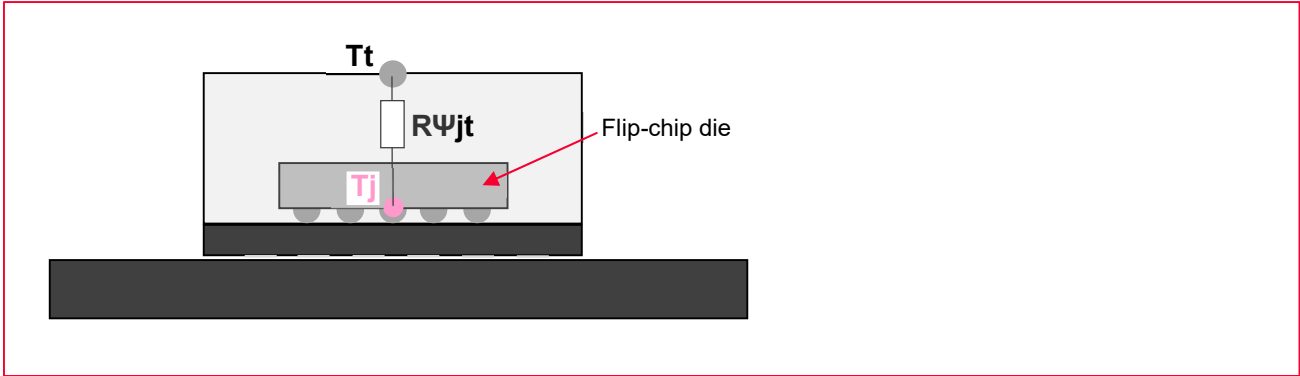

10 Power Sequence

10.1 Power-On Sequence

This section describes the power-on sequences along with their parameters.

- VDD must be good (90%) before asserting NRST_MCU (= 0 to 1).

Figure 5: Power-On Sequence Graph

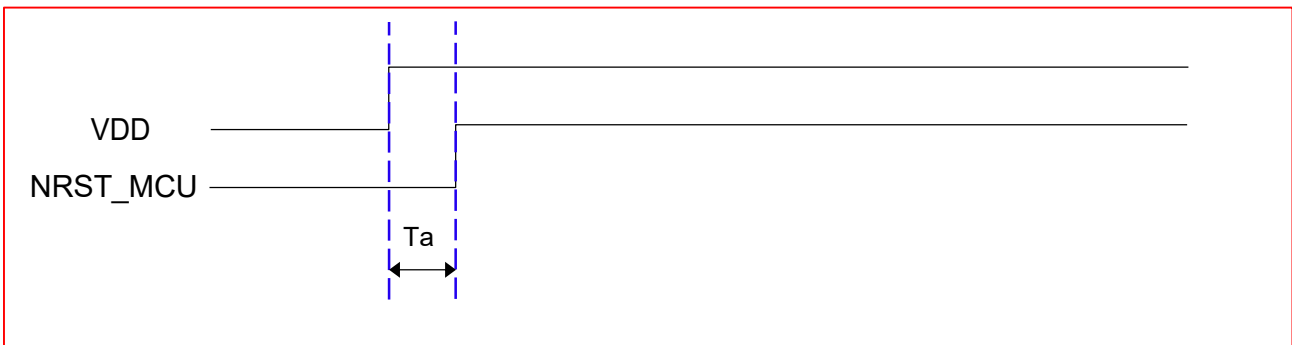

Table 12: Parameters for Power-On Sequence Graph

Symbol	Parameter	Minimum	Typical	Maximum	Unit
Ta	VDD to NRST_MCU time	3.0			ms

10.2 Power-Off Sequence

This section describes the power-off sequences along with their parameters.

- VDD should be off (10%) after asserting NRST_MCU (= 1 to 0).

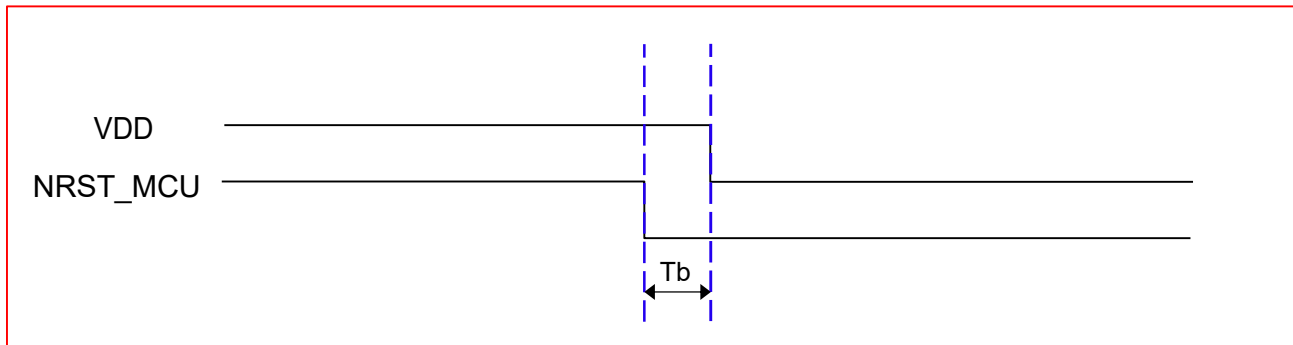
Figure 6: Power-Off Sequence Graph

Table 13: Parameters for Power-Off Sequence Graph

Symbol	Parameter	Minimum	Typical	Maximum	Unit
Tb	NRST_MCU to VDD time	0			ms

11 Interface Specification

11.1 USB Specifications

The USB interface is fully compliant with the USB specification version 2.0 and is USB-IF certified (for Full-speed device operation).

For more details, please refer to the STM32WB55 data sheet.

Table 14: USB electrical characteristics

Symbol	Parameter	Conditions (1)	Minimum	Typical	Maximum	Unit
VDDUSB	USB transceiver operating voltage		3.0(2)	-	3.6	V
T _{crystal_less}	USB crystal-less operation temperature		-15	-	85	°C
RPUI	Embedded USB_DP pull-up value during idle		900	1250	1600	Ω
RPUR	Embedded USB_DP pull-up value during reception		1400	2300	3200	Ω
ZDRV (3)	Output driver impedance (4)	Driving high and low	28	36	44	Ω

1. TA = -40 to 125 °C unless otherwise specified.
2. The STM32WB55xx USB functionality is ensured down to 2.7 V, but the full USB electrical characteristics are degraded in the 2.7 to 3.0 V voltage range.
3. Guaranteed by design.
4. No external termination series resistors are required on USB_DP (D+) and USB_DM (D-); the matching impedance is already included in the embedded driver.

11.2 LPUART Specifications

The LPUARTs support half-duplex single wire communication and modem operations (CTS/RTS), allowing multiprocessor communication.

The LPUART has a clock domain independent from the CPU clock and can wake up the system from Stop mode using baud rates up to 220 Kbps.

Only a 32.768 kHz clock (LSE) is needed to allow LPUART communication up to 9600 baud. Therefore, even in Stop mode, the LPUARTs can wait for an incoming frame while having an extremely low energy consumption. A higher speed clock can be used to reach higher baud rates.

For more details, please refer to the STM32WB55 data sheet.

11.3 I2C Specifications

The I2C bus interface handles communications between the microcontroller and the serial I2C bus. It controls all I2C bus-specific sequencing, protocol, arbitration, and timing.

For more details, please refer to the STM32WB55 data sheet.

Table 15: I2C Implementation

I2C features (1)	I2C
Standard-mode (up to 100 kbit/s)	√
Fast-mode (up to 400 kbit/s)	√
Fast-mode Plus with 20mA output drive I/Os (up to 1 Mbit/s)	√
Programmable analog and digital noise filters	√
SMBus/PMBus hardware support	√
Independent clock	√
Wakeup from Stop 0 / Stop 1 mode on address match	√
Wakeup from Stop 2 mode on address match	X

1. √: supported, X: not supported.

Table 16: I2C analog filter characteristic

Symbol	Parameter	Minimum	Maximum	Unit
t _{AF}	Maximum pulse width of spikes that are suppressed by the analog filter	50(1)	260(2)	ns

- Spikes with widths below t_{AF(min)} are filtered.
- Spikes with widths above t_{AF(max)} are not filtered.

11.4 SPI Specifications

The SPI interface allows communication up to 32 Mbit/s in master and up to 24 Mbit/s in slave modes, in half-duplex, full-duplex, and simplex modes. The 3-bit prescaler gives 8 master mode frequencies and the frame size is configurable from 4 bits to 16 bits. The SPI interfaces support NSS pulse mode, TI mode, and Hardware CRC calculation.

For more details, please refer to the STM32WB55 data sheet.

11.5 SWD Specifications

The Arm® SWJ-DP interface is embedded, it is a combined JTAG and serial wire debug port that enables either a serial wire debug or a JTAG probe to be connected to the target.

Debug is performed using only two pins instead of the five required by the JTAG (JTAG pins can then be reused as GPIOs with alternate functions): the JTAG TMS and TCK pins are shared with SWDIO and SWCLK, respectively, and a specific sequence on the TMS pin is used to switch between JTAG-DP and SW-DP.

For more details, please refer to the STM32WB55 data sheet.

12 DC/RF Characteristics

ALL DC/RF characteristics are defined by the following files as shown in **Table 17. Figure 7**: Burst current definition shows the burst current definition for the Type 1WL-857 module.

Table 17: DC/RF Characteristics and Files

Characteristics	Filenames
LoRa	LR1110 firmware version 0x0308, aos-mfg-v1.4-3.elf
BLE	Wireless Firmware version (BLE STACK) 1.13.0, aos-mfg-v1.4-3.elf
Wi-Fi Passive Scan	LR1110 firmware version 0x0308, aos-mfg-v1.4-3.elf
LR1110 GNSS Scan	LR1110 firmware version 0x0308, aos-mfg-v1.4-3.elf

Figure 7: Burst current definition

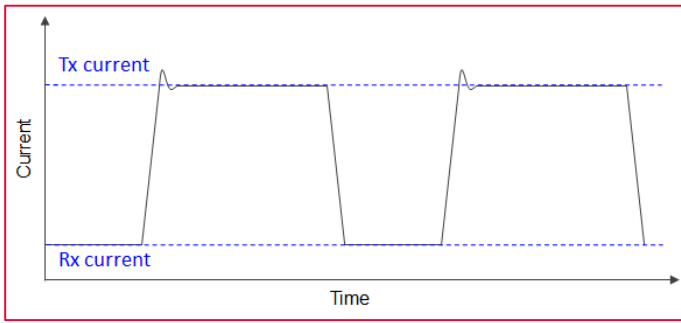

12.1 Sleep Current

Conditions: 25 °C, VDD = 3.3V, LR1110 firmware version 0x0308, Application FW: AT3.

Table 18: Sleep Current Specifications

Items	Condition	Contents			
		Minimum	Typical	Maximum	Unit
Current Consumption					
Supply current in sleep mode	MCU in stop2 mode with RTC, LR1110 OFF.		4.7		µA

12.2 DC/RF Characteristics for Sub-GHz

Conditions: 25 °C, VDD = 3.3V, LR1110 firmware version 0x0308, Application FW: 1.4-3.

Table 19: Sub-GHz Bands Specifications

Items	Condition	Contents			
		Minimum	Typical	Maximum	Unit
Current Consumption					
Supply current in receiver FSK mode	RxBoost OFF		15.4		mA
	RxBoost ON		17.5		mA
Supply current in receiver LoRa mode, RxBoost OFF ⁽¹⁾	BW=125KHz, SF = 7		6.8		mA
	BW=125KHz, SF = 12		6.8		mA
	BW=250KHz, SF = 7		7.1		mA
	BW=250KHz, SF = 12		7.1		mA
	BW=500KHz, SF = 7		7.3		mA
	BW=500KHz, SF = 12		8.9		mA
Supply current in receiver LoRa mode, RxBoost ON ⁽¹⁾	BW=125KHz, SF = 7		9.0		mA
	BW=125KHz, SF = 12		9.2		mA
	BW=250KHz, SF = 7		9.2		mA
	BW=250KHz, SF = 12		9.5		mA
	BW=500KHz, SF = 7		6.8		mA
	BW=500KHz, SF = 12		6.9		mA
Supply current in LoRa transmitter mode	LP PA 14dBm setting		28		mA
	HP PA 22dBm setting		115		mA

Items	Condition	Contents			
		Minimum	Typical	Maximum	Unit
Tx Characteristics					
TX Output Power	LP PA 14dBm setting	10.5	13.5		dBm
	HP PA 22dBm setting	18	21		dBm
RF Output Power Stability vs Voltage Supply (3.0~3.3V)	LP PA Operating		0.1		dB
	HP PA Operating		0.6		dB
RF Output Power Stability vs Temperature (-40~+85°C)	LP PA Operating		1.3		dB
	HP PA Operating		1.3		dB
TX Power Range	Programmable in steps of -1dB from maximum TX power		31		steps
Rx Characteristics					
Sensitivity 2-FSK, RxBoost OFF	BRF = 4.8 kb/s, FDA = 5 kHz, BWF = 20 kHz		-116		dBm
Sensitivity 2-FSK, RxBoost ON	BRF = 4.8 kb/s, FDA = 5 kHz, BWF = 20 kHz		-117		dBm
Sensitivity LoRa, RxBoost OFF	BWL = 125 kHz, SF = 7		-125		
	BWL = 125 kHz, SF = 12		-139		
	BWL = 250 kHz, SF = 7		-122		
	BWL = 250 kHz, SF = 12		-136		
	BWL = 500 kHz, SF = 7		-118		
	BWL = 500 kHz, SF = 12		-132		
Sensitivity LoRa, RxBoost ON	BWL = 125 kHz, SF = 7		-127		
	BWL = 125 kHz, SF = 12		-141		
	BWL = 250 kHz, SF = 7		-124		
	BWL = 250 kHz, SF = 12		-138		
	BWL = 500 kHz, SF = 7		-120		
	BWL = 500 kHz, SF = 12		-134		
	(1) MCU is under sleep mode when test RX current.				

12.3 DC/RF Characteristics for Wi-Fi Passive Scanner

Conditions: 25 °C, VDD = 3.3V, LR1110 firmware version 0x0308, Application FW: 1.4-3.

Table 20: Wi-Fi Passive Scanner Specifications

Items	Condition	Contents			
		Minimum	Typical	Maximum	Unit
Wi-Fi Passive Scan Characteristics					
RX input frequency	Wi-Fi channels	2412	-	2484	MHz
Supply Current in Wi-Fi scan mode	Preamble detect phase		13.6		mA
	Capture phase		12		mA
	Processing phase		4		mA
Wi-Fi sensitivity for Wi-Fi 802.11 b, DSSS	DBPSK, DR = 1Mb/s		-93		dBm

Items	Condition	Contents			
Wi-Fi sensitivity for Wi-Fi 802.11 g, OFDM, 20MHz channel spacing	BPSK, CR = 1/2, DR = 6 Mb/s		-88		dBm
Wi-Fi sensitivity for Wi-Fi 802.11 n, OFDM, 20MHz channel spacing, short guard interval	BPSK, CR = 1/2, DR = 7.2 Mb/s		-86		dBm

12.4 DC/RF Characteristics for Bluetooth Low Energy

Items	Contents
Bluetooth specification (power class)	Version 5.2 (LE)
Channel frequency (spacing)	2402 to 2480 MHz (2 MHz)
Number of RF Channel	40

12.4.1 1 Mbps PHY Condition

Conditions: 25 °C, VDD = 3.3V, BLE STACK FW: 1.13.0, Application FW: 1.4-3.

Table 21: BLE 1 Mbps PHY Specifications

Items	Contents			
Current Consumption				
	Minimum	Typical	Maximum	Unit
• Tx mode, Max output power		20.8		mA
• Rx mode		13.5		mA
Tx Characteristics				
	Minimum	Typical	Maximum	Unit
Center Frequency	2402		2480	MHz
Channel Spacing		2		MHz
Number of RF channel		40		
Max Output power		5		dBm
In-band emission				
• $f_{TX} \pm 2$ MHz			-20	dBm
• $f_{TX} \pm [3+n]$ MHz; n = 0,1,2...			-30	dBm
Modulation Characteristics				
• Δf_{1avg}	225		275	kHz
• Δf_{2max} (at 99.9%)	185			kHz
• $\Delta f_{2avg} / \Delta f_{1avg}$	0.8			
Stable Modulation Characteristics				
• Δf_{1avg}	247.5		252.5	kHz
• Δf_{2max} (at 99.9%)	185			kHz
• $\Delta f_{2avg} / \Delta f_{1avg}$	0.8			
Carrier frequency offset and drift				
• Frequency offset (f_n); n = 0,1,2,3...k	-150		150	kHz
• Frequency drift ($ f_0 - f_n $); n = 2,3,4...k			50	kHz
• Drift rate				

Items	Contents			
• $ f_1 - f_0 $			20	kHz
• $ f_n - f_{n-5} $; $n = 6, 7, 8, \dots, k$			20	kHz
Spurious Emissions				
• 30 - 47 MHz (BW = 100 kHz)			-36	dBm
• 47 - 74 MHz (BW = 100 kHz)			-54	dBm
• 74 - 87.5 MHz (BW = 100 kHz)			-36	dBm
• 87.5 - 118 MHz (BW = 100 kHz)			-54	dBm
• 118 - 174 MHz (BW = 100 kHz)			-36	dBm
• 174 - 230 MHz (BW = 100 kHz)			-54	dBm
• 230 - 470 MHz (BW = 100 kHz)			-36	dBm
• 470 - 862 MHz (BW = 100 kHz)			-54	dBm
• 862 - 1000 MHz (BW = 100 kHz)			-36	dBm
• 1000 - 12750 MHz (BW = 1 MHz)			-30	dBm
Rx Characteristics	Minimum	Typical	Maximum	Unit
Receiver sensitivity (PER < 30.8%)		-93	-70	dBm
Maximum input signal level (PER < 30.8%)	0			dBm
PER Report Integrity (-30 dBm input)	50		65.4	%

12.4.2 2 Mbps PHY Condition

Conditions: 25 °C, VDD = 3.3V, BLE STACK FW: 1.13.0, Application FW: 1.4-3.

Table 22: BLE 2 Mbps PHY Specifications

Items	Contents			
Current Consumption	Minimum	Typical	Maximum	Unit
• Tx mode, Max output power		20.8		mA
• Rx mode		14.1		mA
Tx Characteristics	Minimum	Typical	Maximum	Unit
Center Frequency	2402		2480	MHz
Channel Spacing		2		MHz
Number of RF channel		40		
Max Output power		5		dBm
In-band emission				
• $f_{TX} \pm 4$ MHz			-20	dBm
• $f_{TX} \pm 5$ MHz			-20	dBm
• $f_{TX} \pm [6+n]$ MHz; $n = 0, 1, 2, \dots$			-30	dBm
Modulation Characteristics				
• $\Delta f_{1\text{avg}}$	450		550	kHz
• $\Delta f_{2\text{max}}$ (at 99.9%)	370			kHz
• $\Delta f_{2\text{avg}} / \Delta f_{1\text{avg}}$	0.8			-

Items	Contents			
Stable Modulation Characteristics				
• $\Delta f_{1\text{avg}}$	495		505	kHz
• $\Delta f_{2\text{max}}$ (at 99.9%)	370			kHz
• $\Delta f_{2\text{avg}} / \Delta f_{1\text{avg}}$	0.8			
Carrier frequency offset and drift				
• Frequency offset (f_n); $n = 0, 1, 2, 3 \dots k$	-150		150	kHz
• Frequency drift ($ f_0 - f_n $); $n = 2, 3, 4 \dots k$			50	kHz
• Drift rate				
• $ f_1 - f_0 $			20	kHz
• $ f_n - f_{n-5} $; $n = 6, 7, 8, \dots k$			20	kHz
Spurious Emissions				
• 30 - 47 MHz (BW = 100 kHz)			-36	dBm
• 47 - 74 MHz (BW = 100 kHz)			-54	dBm
• 74 - 87.5 MHz (BW = 100 kHz)			-36	dBm
• 87.5 - 118 MHz (BW = 100 kHz)			-54	dBm
• 118 - 174 MHz (BW = 100 kHz)			-36	dBm
• 174 - 230 MHz (BW = 100 kHz)			-54	dBm
• 230 - 470 MHz (BW = 100 kHz)			-36	dBm
• 470 - 862 MHz (BW = 100 kHz)			-54	dBm
• 862 - 1000 MHz (BW = 100 kHz)			-36	dBm
• 1000 - 12750 MHz (BW = 1 MHz)			-30	dBm
Rx Characteristics	Minimum	Typical	Maximum	Unit
Receiver sensitivity (PER < 30.8%)		-90	-70	dBm
Maximum input signal level (PER < 30.8%)	0			dBm
PER Report Integrity (-30 dBm input)	50		65.4	%

12.5 DC/RF Characteristics for GNSS

12.5.1 LR1110 GNSS Scanner Receiver Specification

Conditions: 25 °C, VDD = 3.3V, LR1110 firmware version 0x0308, Application FW: 1.4-3.

Table 23: LR1110 GNSS Scanner Receiver Specifications

Items	Condition	Contents			
		Minimum	Typical	Maximum	Unit
Current Consumption					
Supply current in GNSS scan mode	Capture phase		15.2		mA
	Processing phase		6.3		mA
RX input frequency	GPS		1575.42		MHz
	BeiDou		1561.1		MHz
GNSS sensitivity	GPS, indoor classification, and strong signal SV capture		-133		dBm
	BeiDou, strong signal SV capture		-130		dBm

13 Land Pattern

The land pattern (top view, Unit: mm) is shown in **Figure 8**.

Figure 8: Land Pattern

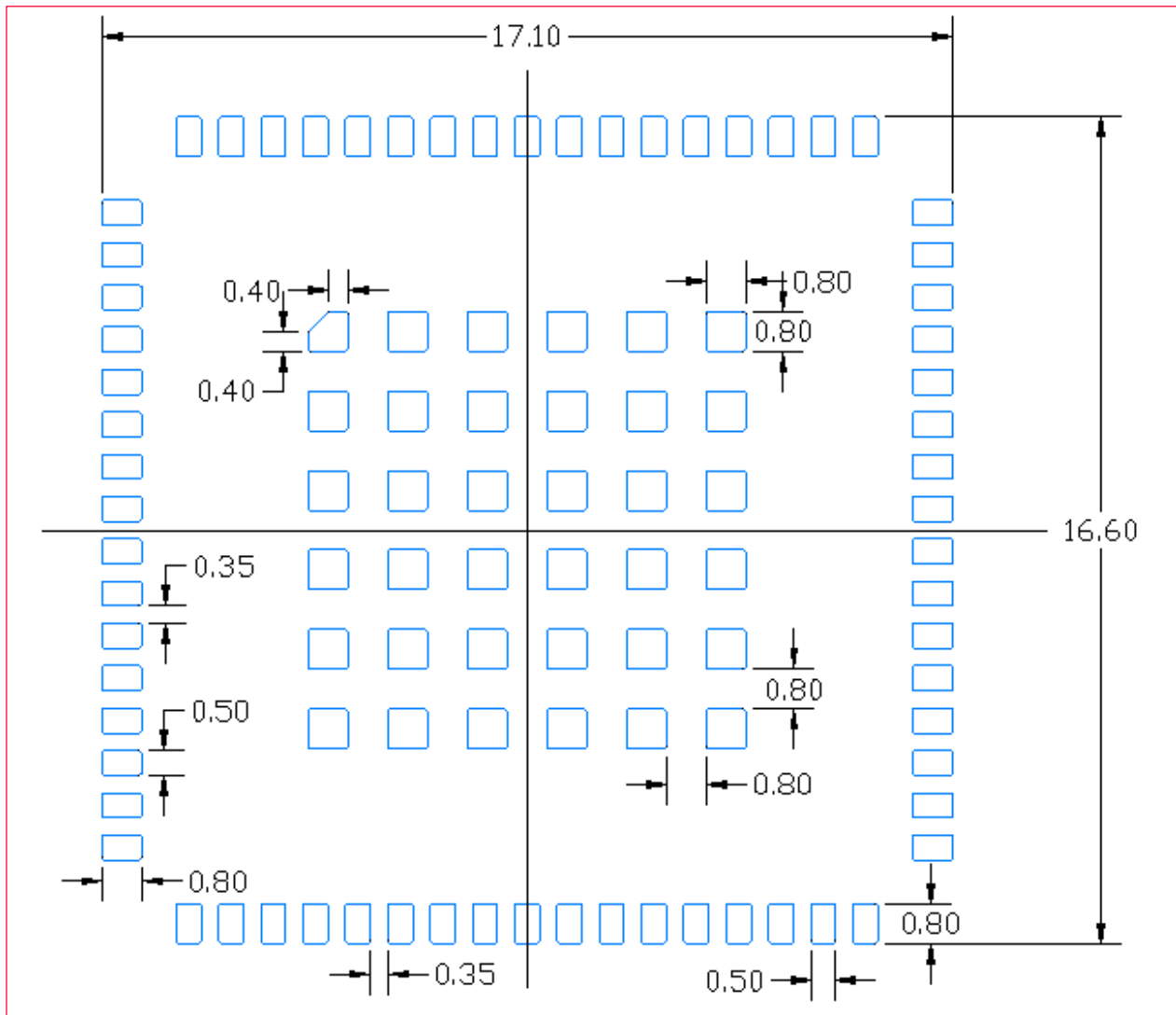

14 Reference Circuit



NRST_MCU pin has a 0.1uF capacitor inside of module. No need external capacitor outside module.

Figure 9: Reference Circuit

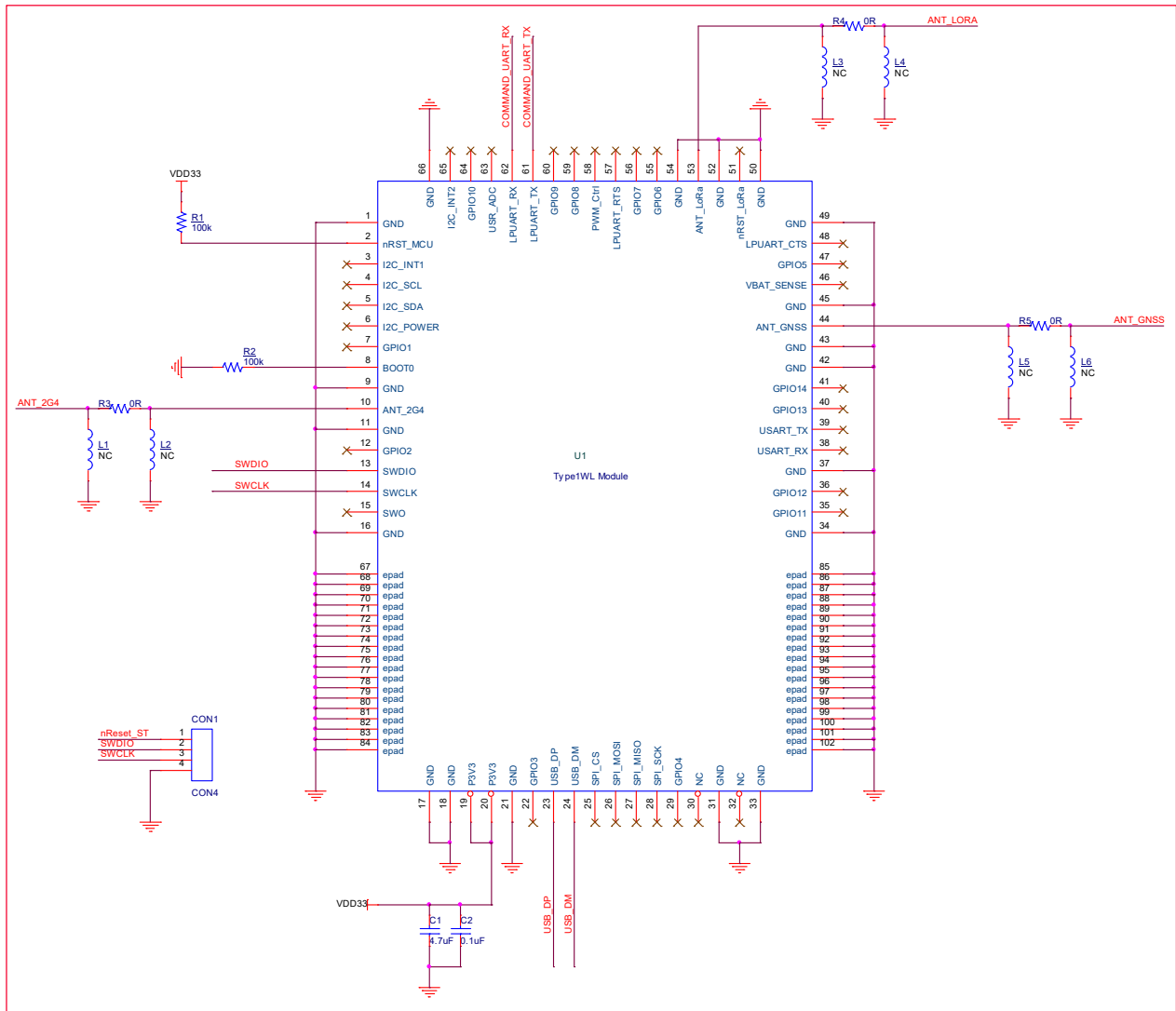

15 General Regulatory Certification for LBEU5ZZ1WL

This section contains the following topics:

- Application model part number
- Label
- Package Label
- Country of Origin

15.1 Application Model Part Number

We apply for “LBEU5ZZ1WL” in each country.

15.2 Marking

Figure 10 shows the Marking Information of the Type 1WL-857 module.

Figure 10: Marking Information



Since there is no space to describe the notational requirements of each country, we are applying for the notational requirements to be posted in the manual or package.

15.3 Certification Label

Figure 11 shows the certification label information (Humidity Proof Packing).

Figure 11: Certification Label (Humidity proof Packing)

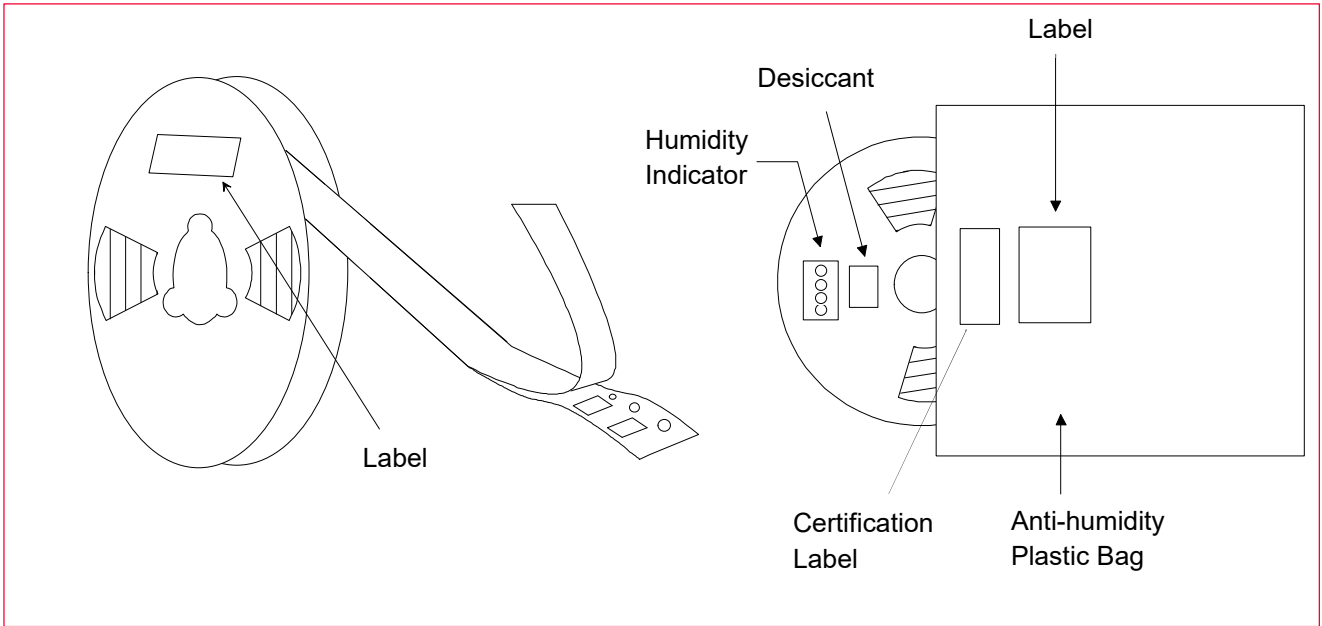

The Certification label may be attached on one side only.

Certification label example is shown as **Figure 12**.

Figure 12: Certification Label Example



15.4 Country of Origin

China

SHENZHEN MURATA TECHNOLOGY CO., LTD.

Some countries have applied for two countries, China, and Japan, in preparation for future factory changes, but the production site in the delivery specifications is the above-mentioned factory in China.

16 Radio Regulatory Certification by Country for LBEU5ZZ1WL

This section includes the following regulatory certifications:

- JRL
- FCC
- ISED
- CE

16.1 JRL

- Manufacturer: Murata Manufacturing Co., Ltd.
- Model or Product Name: LBEU5ZZ1WL
- This module has received "**Certificate of Construction Type**" under the Japanese Radio Law.

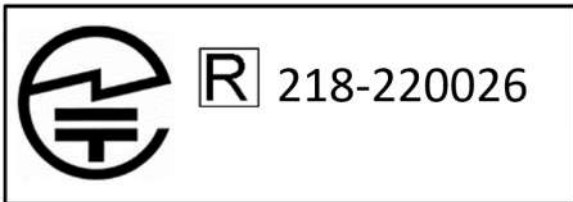

16.1.1 Power Level for Japan

Table 24 shows the maximum radio frequency power to transmit within the operating frequency band.

Table 24: Japan Maximum Radio Frequency Power - All Mode

Band	Maximum Tune Up Tolerance [dBm]
Sub-GHz	12.3 ± 1.5
BLE	5.0 ± 2.0

16.1.2 About Notations

It is recommended that the indication below is described on the product incorporating this module in Japanese. If there is any problem with the indication on the product, we recommend indicating in the user manual or on the package of the product incorporating this module, or electronic display on

the product. In the case of the electronic display, it is necessary to describe "using the electronic display" + "how to reach to below indication" in the user manual of the product.

- Recommended Indication

Japanese Version 本製品は、電波法に基づく工事設計認証(認証番号: 218-220026)を受けた特定無線設備を内蔵しています。
English Version This product incorporates specified radio equipment that has received CERTIFICATION for TYPE CERTIFICATION (certification number: 218-220026) based on the Japan Radio Act.

16.2 FCC

FCC ID: VPYLB1WL

This module is not directly sold to general end users. Therefore, there is no user manual of module. For the details about this module, please refer to the specification sheet of the module.



This module should be installed in the host device according to the interface specification (installation procedure).

16.2.1 Power Level for FCC

Table 25 shows the maximum radio frequency power to transmit within the operating frequency band.

Table 25: FCC Maximum Radio Frequency Power - All Mode

Band	Maximum Tune Up Tolerance [dBm]
Sub-GHz	21.0 ± 2.0
BLE	5.0 ± 2.0

16.2.2 Information to Include in the User Manual

The following statements must be described in the user manual of the host device of this module.

- Contains Transmitter Module FCC ID: VPYLB1WL or Contains FCC ID: VPYLB1WL



This device complies with part 15 of the FCC Rules. Operation is subject to the following two conditions:

- This device may not cause harmful interference
- This device must accept any interference received, including interference that may cause undesired operation.



If it is difficult to describe this statement on the host product due to the size, please describe in the User's manual.

16.3 ISED

HVIN : LBEU5ZZ1WL

PMN : Geolocation Module

IC: 772C-LB1WL

This module is not sold to general end users directly. Therefore, there is no user manual of the module.

For the details about this module, please refer to the specification sheet of the module.



This module should be installed in the host device according to the interface specification (installation procedure).

16.3.1 Information to Display on Host Device and User Manual

16.3.1.1 Information on Host Device

The following information must be indicated on the host device of this module.

- Contains IC: 772C-LB1WL

16.3.1.2 Information in User Manual

The following statements must be described on the user manual of the host device of this module.

English Version

This device complies with Industry Canada's applicable licence-exempt RSSs. Operation is subject to the following two conditions:

- This device may not cause interference
- This device must accept any interference, including interference that may cause undesired operation of the device.

French Version

Le présent appareil est conforme aux CNR d'Industrie Canada applicables aux appareils radio exempts de licence. L'exploitation est autorisée aux deux conditions suivantes :

- l'appareil ne doit pas produire de brouillage;
- l'utilisateur de l'appareil doit accepter tout brouillage radioélectrique subi, même si le brouillage est susceptible d'en compromettre le fonctionnement.



If it is difficult to describe this statement on the host product due to the size, please describe in the User's manual.

16.3.2 Power Level for ISED

Table 27 shows the maximum radio frequency power to transmit within the operating frequency band.

Table 26: ISED Maximum Radio Frequency Power - All Mode

Band	Maximum Tune Up Tolerance [dBm]
Sub-GHz	21.0 ± 2.0
BLE	5.0 ± 2.0

16.4 Europe

Product name: Geolocation Module

Model: LBEU5ZZ1WL

Manufacturer: Murata Manufacturing Co., Ltd.



When shipping final products with this module to Europe, make a self-declaration that the final product complies with European regulations and apply the CE mark.

The following standard reports have been published:

- EN 300 328 V2.2.2
- EN 300 220-2 V3.2.1
- EN 303 413 V1.2.1
- EN IEC 62311:2020

These reports can be leveraged as part of the TCF of the final product. We believe that the conducted test can be used directly as the TCF of the final product. The radiated test as TCF for the final product should be performed by you again with the final product.

16.4.1 Power Level for Europe

Table 27 shows the maximum radio frequency power to transmit within the operating frequency band.

Table 27: Europe Maximum Radio Frequency Power - All Mode

Band	Maximum Tune Up Tolerance [dBm]
Sub-GHz	13.5 ± 2.0
BLE	5.0 ± 2.0

17 Tape and Reel Packing

This section provides the general specifications for tape and reel packing.

17.1 Dimensions of Tape (Plastic Tape)

The dimensions of the tape are as follows:

- The corner and ridge radiuses (R) of the inside cavity are 0.3 mm maximum.
- Cumulative tolerance of 10 pitches of the sprocket hole is ± 0.15 mm
- Measuring of cavity positioning is based on cavity center in accordance with JIS/IES standards.

Figure 13 is a graphical representation of the tape dimension (plastic tape).

Figure 13: Dimensions of Tape (Plastic tape)

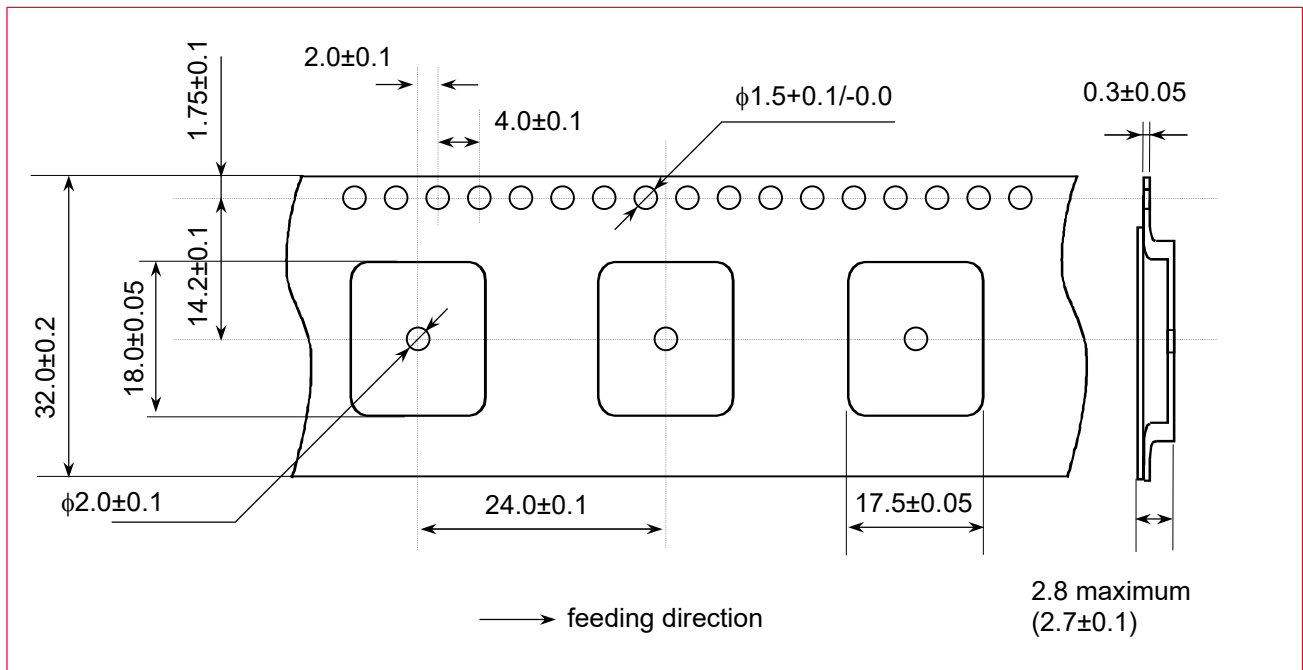

17.2 Dimensions of Reel

Figure 14 shows the reel dimensions.

Figure 14: Dimensions of Reel (Unit: mm)

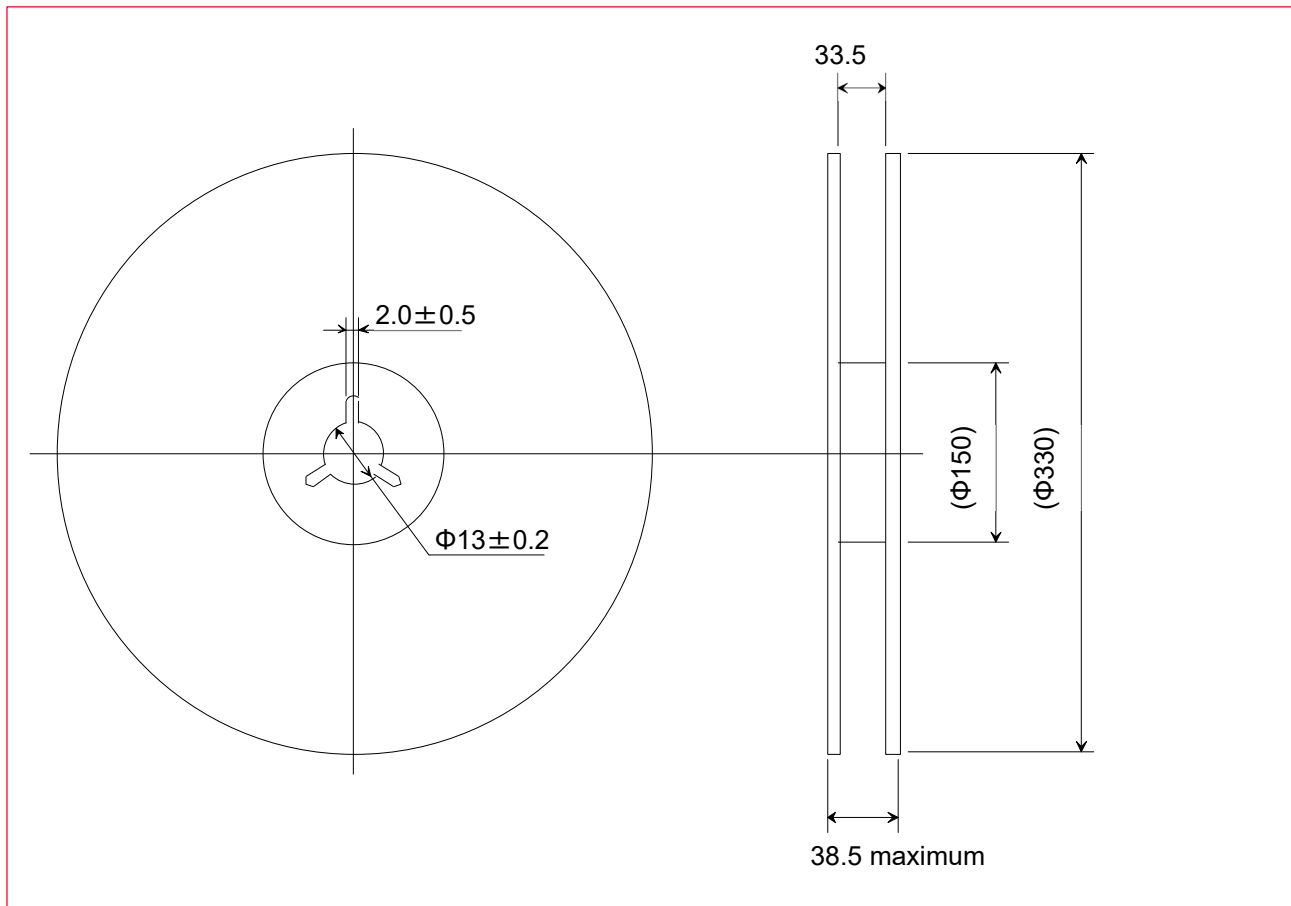

17.3 Taping Diagrams

Figure 15 shows the tapings diagrams.

Figure 15: Taping Diagrams

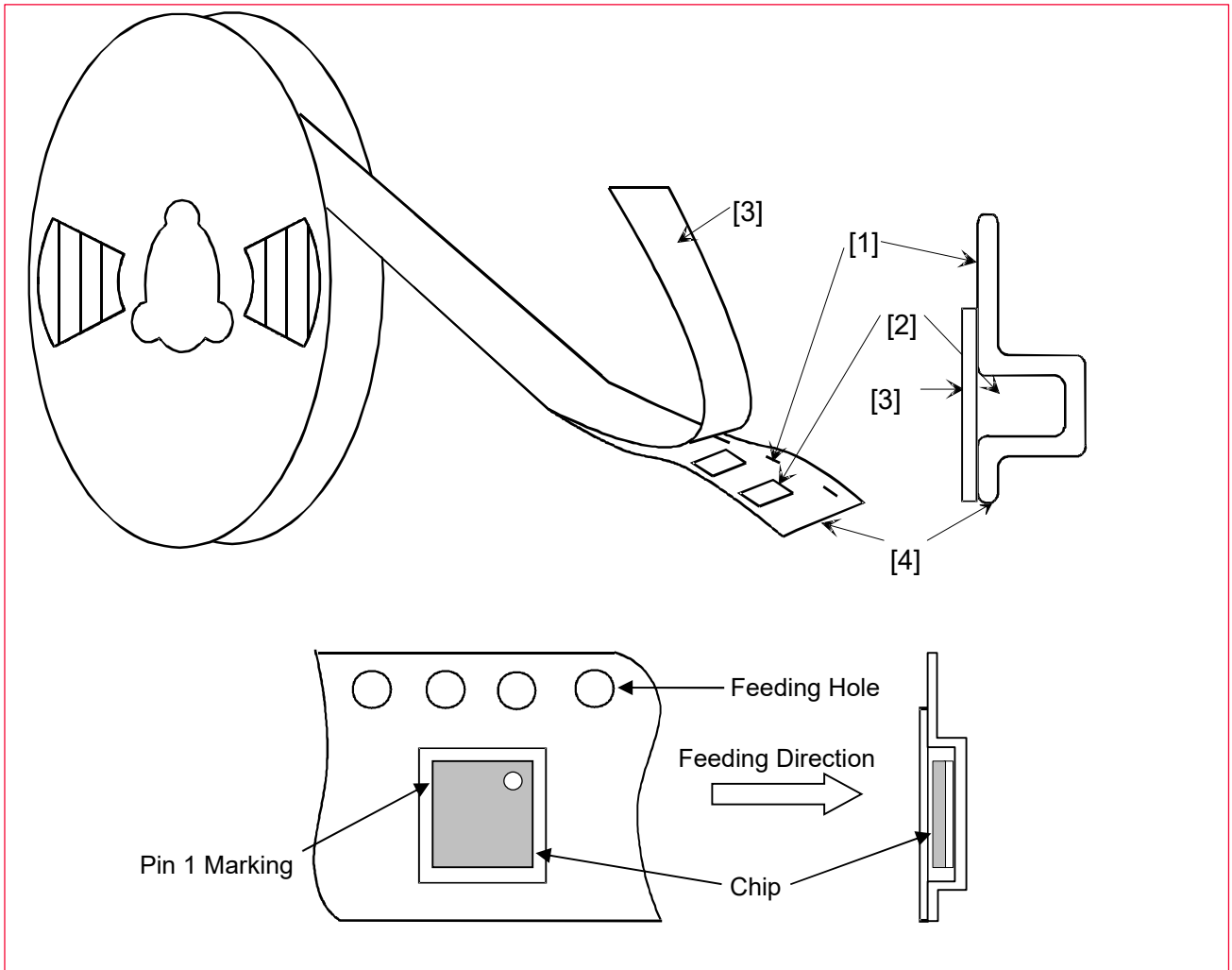

Table 28: Taping Specifications

Mark	Description
1	Feeding hole. As specified in Dimensions of Tape (Plastic tape) ☐☐.
2	Hole for Chip. As specified in Dimensions of Tape (Plastic tape) ☐☐.
3	Cover tape. 62 μm in thickness.
4	Base tape. As specified in Dimensions of Tape (Plastic tape) ☐☐.

17.4 Leader and Tail Tape

The leader and tail tape are shown in **Figure 16**.

Figure 16: Leader and Tail Tape

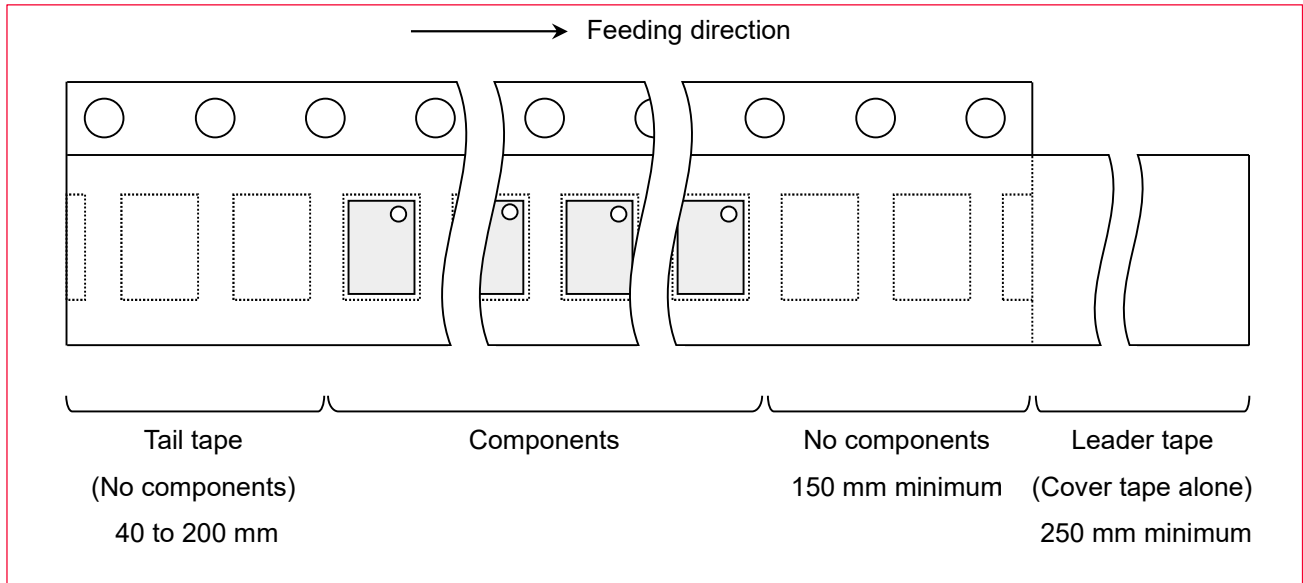

- The tape for chips is wound clockwise, the feeding holes to the right side as the tape is pulled toward the user.
- The cover tape and base tape are not adhered at no components area for 250 mm minimum
- Tear off strength against pulling of cover tape: 5 N minimum
- Packaging unit: 800 pcs. / Reel
- Tape material:
 - Base tape: Plastic
 - Reel: Plastic
 - Cover tape, cavity tape and reel are made the anti-static processing.
- Peeling off force: 1.3 N maximum in the direction of peeling as shown in **Figure 17**.

Figure 17: Peeling Force

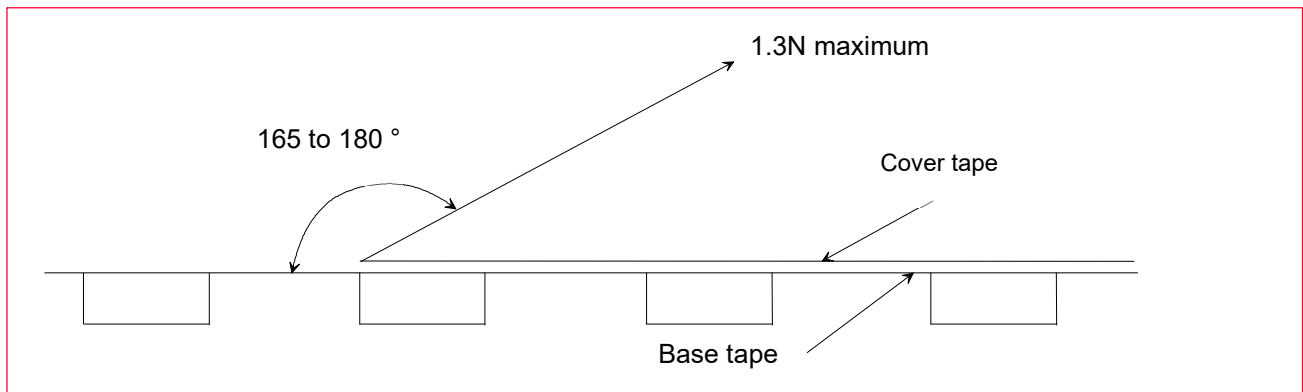

17.5 Packaging (Humidity Proof Packing)

Figure 18 shows the humidity-proof packaging.

Figure 18: Humidity Proof Packaging

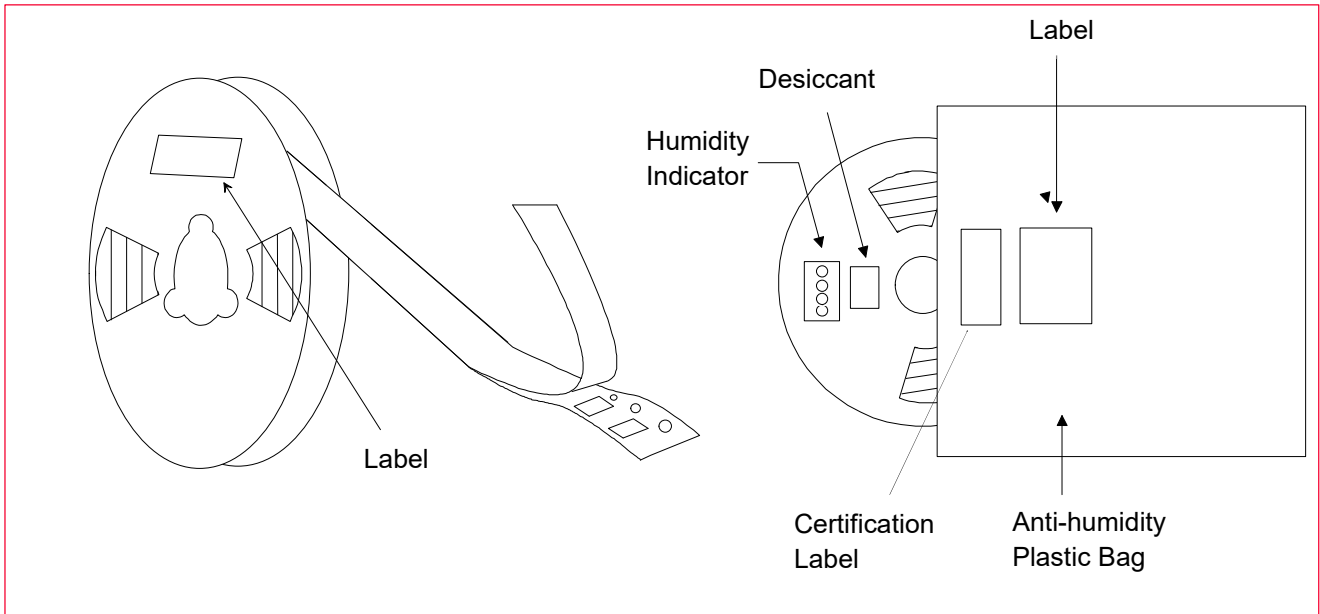

Tape and reel must be sealed with the anti-humidity plastic bag. The bag contains the desiccant and the humidity indicator.

18 Notice

18.1 Storage Conditions

- Please use this product within 6 months after receipt.
- The product shall be stored without opening the packing under the ambient temperature of 5 to 35 °C and humidity from 20 ~ 70 %RH (Packing materials may be deformed at a temperature over 40 °C).
- The product left more than 6 months after reception; it needs to be confirmed the solderability before use.
- The product *must* be stored in noncorrosive gas (Cl₂, NH₃, SO₂, NO_x, etc.).
- Any excess mechanical shock including, but not limited to, sticking the packing materials with sharp object and dropping the product, *must* not be applied in order not to damage the packing materials.
- This product is applicable to MSL3 (Based on JEDEC Standard J-STD-020)
 - After the packing is opened, the product *must* be stored at ≤30 °C / <60 %RH and the product *should* be used within 168 hours after opening.

- When the color of the indicator in the packing changed, the product shall be baked before soldering.
- Baking condition: 125 +5/-0 °C, 24 hours, 1 time
- The products must be baked on the heat-resistant tray because the material (Base Tape, Reel Tape and Cover Tape) is not heat-resistant.

18.2 Handling Conditions

- Be careful in handling or transporting products because excessive stress or mechanical shock may break products.
- Handle with care if products may have cracks or damages on their terminals. If there is any such damage, the characteristics of products may change. *Do not touch* products with bare hands that may result in poor solder ability and destroy by static electrical charge.

18.3 Standard PCB Design (Land Pattern and Dimensions)

- All the ground terminals should be connected to the ground patterns. Furthermore, the ground pattern should be provided between IN and OUT terminals. Please refer to the specifications for the standard land dimensions.
- The recommended land pattern and dimensions is as Murata's standard. The characteristics of products may vary depending on the pattern drawing method, grounding method, land dimensions, land forming method of the NC terminals and the PCB material and thickness. Therefore, be sure to verify the characteristics in the actual set. When using non-standard lands, contact Murata beforehand.

18.4 Notice for Chip Placer

When placing products on the PCB, products may be stressed and broken by uneven forces from a worn-out chucking locating claw or a suction nozzle. To prevent products from damages, be sure to follow the specifications for the maintenance of the chip placer being used. For the positioning of products on the PCB, be aware that mechanical chucking may damage products.

18.5 Soldering Conditions

The recommendation conditions of soldering are as in the following figure.

Soldering must be carried out by the above-mentioned conditions to prevent products from damage. Set up the highest temperature of reflow within 260 °C. Contact Murata before use if concerning other soldering conditions.

Figure 19: Reflow soldering standard conditions (Example)

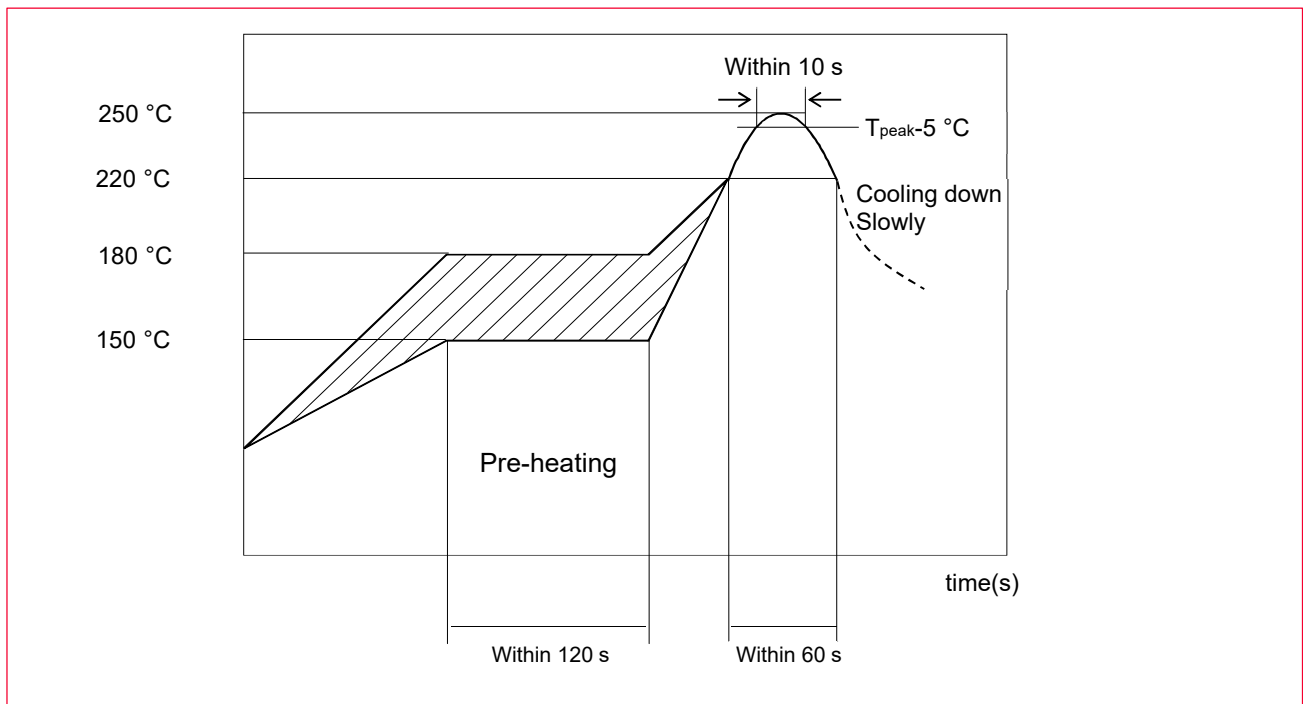

Please use the reflow within 2 times.

Use rosin type flux or weakly active flux with a chlorine content of 0.2 wt % or less.

18.6 Cleaning

Since this Product is Moisture Sensitive, any cleaning is not recommended. If any cleaning process is done the customer is responsible for any issues or failures caused by the cleaning process.

18.7 Operational Environment Conditions

Products are designed to work for electronic products under normal environmental conditions (ambient temperature, humidity, and pressure). Therefore, products have no problems to be used under the similar conditions to the above-mentioned. However, if products are used under the following circumstances, it may damage products and leakage of electricity and abnormal temperature may occur.

- In an atmosphere containing corrosive gas (Cl₂, NH₃, SO_x, NO_x etc.).
- In an atmosphere containing combustible and volatile gases.
- Dusty place.
- Direct sunlight place.
- Water splashing place.
- Humid place where water condenses.
- Freezing place.



If there are possibilities for products to be used under the preceding clause, consult with Murata before actual use.



Do not apply static electricity or excessive voltage while assembling and measuring, as it might be a cause of degradation or destruction to apply static electricity to products.

18.8 Input Power Capacity

Products shall be used in the input power capacity as specified in this specification.

Inform Murata beforehand, in case that the components are used beyond such input power capacity range.

19 Preconditions to Use Our Products



PLEASE READ THIS NOTICE BEFORE USING OUR PRODUCTS.

Please make sure that your product has been evaluated and confirmed from the aspect of the fitness for the specifications of our product when our product is mounted to your product.

All the items and parameters in this product specification/datasheet/catalog have been prescribed on the premise that our product is used for the purpose, under the condition and in the environment specified in this specification. You are requested not to use our product deviating from the condition and the environment specified in this specification.

Please note that the only warranty that we provide regarding the products is its conformance to the specifications provided herein. Accordingly, we shall not be responsible for any defects in products or equipment incorporating such products, which are caused under the conditions other than those specified in this specification.

WE HEREBY DISCLAIM ALL OTHER WARRANTIES REGARDING THE PRODUCTS, EXPRESS OR IMPLIED, INCLUDING WITHOUT LIMITATION ANY WARRANTY OF FITNESS FOR A PARTICULAR PURPOSE, THAT THEY ARE DEFECT-FREE, OR AGAINST INFRINGEMENT OF INTELLECTUAL PROPERTY RIGHTS.

You agree that you will use any and all software or program code (including but not limited to hcd, firmware, nvram, and blob) we may provide or to be embedded into our product ("Software") provided that you use the Software bundled with our product. YOU AGREE THAT THE SOFTWARE SHALL BE PROVIDED TO YOU "AS IS" BASIS, MURATA MAKES NO REPRESENTATIONS OR WARRANTIES THAT THE SOFTWARE IS ERROR-FREE OR WILL OPERATE WITHOUT INTERRUPTION. AND MORE, MURATA MAKES NO REPRESENTATIONS OR WARRANTIES OF ANY KIND WHETHER EXPRESS OR IMPLIED WITH RESPECT TO THE SOFTWARE. MURATA EXPRESSLY DISCLAIM ANY AND ALL WARRANTIES OR CONDITIONS OF MERCHANTABILITY, FITNESS FOR A PARTICULAR PURPOSE NOR THE WARRANTY OF TITLE OR NON-INFRINGEMENT OF INTELLECTUAL PROPERTY RIGHTS.

You shall indemnify and hold harmless us, our affiliates, and our licensor from and against any and all claims, costs, expenses and liabilities (including attorney's fees), which arise in connection with the using the Software.

The product shall not be used in any application listed below which requires especially high reliability for the prevention of such defect as may directly cause damage to the third party's life, body or property. You acknowledge and agree that, if you use our products in such applications, we will not be responsible for any failure to meet such requirements. Furthermore, YOU AGREE TO INDEMNIFY AND DEFEND US AND OUR AFFILIATES AGAINST ALL CLAIMS, DAMAGES, COSTS, AND EXPENSES THAT MAY BE INCURRED, INCLUDING WITHOUT LIMITATION, ATTORNEY FEES AND COSTS, DUE TO THE USE OF OUR PRODUCTS AND THE SOFTWARE IN SUCH APPLICATIONS.

- Aircraft equipment.
- Aerospace equipment.
- Undersea equipment.
- Power plant control equipment.
- Medical equipment.
- Traffic signal equipment.

- Burning / explosion control equipment.
- Disaster prevention / crime prevention equipment.
- Transportation equipment (vehicles, trains, ships, elevator, etc.).
- Application of similar complexity and/ or reliability requirements to the applications listed in the above.

We expressly prohibit you from analyzing, breaking, reverse-engineering, remodeling altering, and reproducing our product. Our product cannot be used for the product which is prohibited from being manufactured, used, and sold by the regulations and laws in the world.

We do not warrant or represent that any license, either express or implied, is granted under any our patent right, copyright, mask work right, or our other intellectual property right relating to any combination, machine, or process in which our products or services are used. Information provided by us regarding third-party products or services does not constitute a license from us to use such products or services or a warranty or endorsement thereof. Use of such information may require a license from a third party under the patents or other intellectual property of the third party, or a license from us under our patents or other intellectual property.

Please do not use our products, our technical information and other data provided by us for the purpose of developing of mass-destruction weapons and the purpose of military use.

Moreover, you must comply with "foreign exchange and foreign trade law", the "U.S. export administration regulations", etc.

Please note that we may discontinue the manufacture of our products, due to reasons such as end of supply of materials and/or components from our suppliers.

By signing on specification sheet or approval sheet, you acknowledge that you are the legal representative for your company and that you understand and accept the validity of the contents herein. When you are not able to return the signed version of specification sheet or approval sheet within 30 days from receiving date of specification sheet or approval sheet, it shall be deemed to be your consent on the content of specification sheet or approval sheet. Customer acknowledges that engineering samples may deviate from specifications and may contain defects due to their development status. We reject any liability or product warranty for engineering samples. In particular we disclaim liability for damages caused by

- The use of the engineering sample other than for evaluation purposes, particularly the installation or integration in the product to be sold by you,
- Deviation or lapse in function of engineering sample,
- Improper use of engineering samples.

We disclaim any liability for consequential and incidental damages.

If you can't agree with the above contents, please contact sales.

Revision History

Revision Code	Date	Changed Item	Comment
-	2022.09.20	-	First release
A	2022.09.21	Added the weight information. Updated the laser mark information on top side. Changed sample par number and EVK part number.	Update
B	2025.5.20	Updated with new format. Updated Features & Benefits. Updated block diagram. Updated the certification information. Added terminal configurations table. Updated VDD power supply range. Change Bluetooth version from 5.0 to 5.2. Added power sequence. Added interface specifications. Updated DC/RF characteristics of Sub-GHz, Wi-Fi passive scanner, Bluetooth low energy and GNSS. Updated tape and reel packing. Updated preconditions to use our products.	Update



Copyright © Murata Manufacturing Co., Ltd. All rights reserved. The information and content in this document are provided “as-is” with no warranties of any kind and are for informational purpose only. Data and information have been carefully checked and are believed to be accurate; however, no liability or responsibility for any errors, omissions, or inaccuracies is assumed.

Wi-Fi® is a registered trademark of Wi-Fi Alliance. The Bluetooth® word mark and logos are registered trademarks owned by Bluetooth SIG, Inc. Other brand and product names are trademarks or registered trademarks of their respective owners.

Specifications are subject to change without notice.