



FEATURES

- Patent protected
- Optimised bipolar output voltages for IGBT/SiC & MOSFET gate drives
- Reinforced insulation to UL62368-1 recognised
- 6kVDC isolation test voltage 'Hi Pot Test'
- Ultra low isolation capacitance
- Surface mount package style
- 12V, 15V & 24V inputs
- +15V/-3V, +15V/-5V & +18V/-2.5V outputs
- Operation to 115°C
- Characterised partial discharge performance
- Characterised CMTI >200kV/μS
- Continuous barrier withstand voltage 2.2kVDC
- Manufactured in the UK

PRODUCT OVERVIEW

The MGJ1T series of DC-DC converters incorporates Murata's proprietary block-coil transformer technology, providing high isolation, low leakage current, and exceptional performance. The MGJ1T series has successfully undergone 1,000 temperature cycles between -40°C and 125°C, demonstrating its ability to withstand the highest levels of thermal stress.

The MGJ1T series is ideal for powering 'high side' and 'low side' gate drive circuits for IGBTs/SiC and MOSFETs in bridge circuits. A choice of asymmetric output voltages allows optimum drive levels for best system efficiency. The MGJ1T series is characterised for high isolation requirements commonly seen in bridge circuits used in motor drives and inverters.

SELECTION GUIDE

Order Code ¹	Nominal Input Voltage	Output Voltage 1	Output Voltage 2	Output Current 1	Output Current 2	Input Current at Rated Load	Output 1		Output 2	
	V	V	V	mA			Load Regulation (Typ) ²	Load Regulation (Max) ²	Load Regulation (Typ) ²	Load Regulation (Max) ²
							%			
MGJ1D121503TMC	12	15	-3	55	55	100	11	14	2	4
MGJ1D121505TMC	12	15	-5	50	50	100	12	15	1	2
MGJ1D121802TMC	12	18	-2.5	48	48	100	9	12	2	4
MGJ1D151503TMC	15	15	-3	55	55	85	10	13	2	4
MGJ1D151802TMC	15	18	-2.5	48	48	85	8	10	2	4
MGJ1D241503TMC	24	15	-3	55	55	50	11	14	2	4
MGJ1D241505TMC	24	15	-5	50	50	50	13	16	1	2
MGJ1D241802TMC	24	18	-2.5	48	48	50	10	13	2	4

SELECTION GUIDE (Continued)

Order Code ¹	Ripple & Noise (Typ) ³	Ripple & Noise (Max) ³	Efficiency (Min)	Efficiency (Typ)	Isolation Capacitance	MTTF ⁴		
	mVp-p		%			pF	MIL.	Tel.
							kHrs	
MGJ1D121503TMC	10	30	66	73	2.5	1895	17003	
MGJ1D121505TMC	10	30	67	76	2.5	1916	19316	
MGJ1D121802TMC	10	30	67	74	2.5	1837	19279	
MGJ1D151503TMC	10	30	67	74	2.5	1856	18508	
MGJ1D151802TMC	10	30	66	74	2.5	1836	18597	
MGJ1D241503TMC	10	30	67	75	2.5	1712	17754	
MGJ1D241505TMC	10	30	70	77	2.5	1713	18330	
MGJ1D241802TMC	10	30	66	74	2.5	1623	18319	

INPUT CHARACTERISTICS

Parameter	Conditions	Min.	Typ.	Max.	Units
Voltage range	Continuous operation, 12V input types	10.8	12	13.2	V
	Continuous operation, 15V input types	13.5	15	16.5	
	Continuous operation, 24V input types	21.6	24	26.4	
Input reflected ripple			5		mA p-p
Leakage current	250VAC/60Hz		<1		μA



25
For full details go to
www.murata.com/en-global/products/power/rohs



1. Components are supplied in tape and reel packaging, please refer to package specification section. Orderable part numbers are MGJ1DXXXXXTMC-R7 (160 pieces per reel), or MGJ1DXXXXXTMC-R13 (710 pieces per reel).
2. Between 50% and 100% rated output current
3. See ripple & noise test method.
4. Calculated using MIL-HDBK-217 FN2 and Telcordia SR-332 calculation model with nominal input voltage at full load.

All specifications typical at T_a=25°C, nominal input voltage and rated output current unless otherwise specified

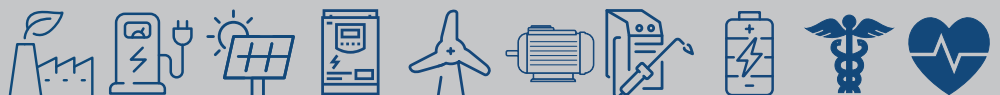

OUTPUT CHARACTERISTICS						
Parameter	Conditions	Min.	Typ.	Max.	Units	
Rated Power	T _A =-40°C to 115°C			1.0	W	
Voltage Set Point Accuracy	See tolerance envelopes					
Line regulation	121503	High V _{IN} to low V _{IN} OP1		1.35	1.7	%/%
		High V _{IN} to low V _{IN} OP2		0.2	0.5	
	121505	High V _{IN} to low V _{IN} OP1		1.45	1.8	
		High V _{IN} to low V _{IN} OP2		0.05	0.1	
	121802	High V _{IN} to low V _{IN} OP1		1.2	1.6	
		High V _{IN} to low V _{IN} OP2		0.2	0.5	
	151503	High V _{IN} to low V _{IN} OP1		1.3	1.7	
		High V _{IN} to low V _{IN} OP2		0.2	0.5	
	151802	High V _{IN} to low V _{IN} OP1		1.2	1.7	
		High V _{IN} to low V _{IN} OP2		0.2	0.5	
	241503	High V _{IN} to low V _{IN} OP1		1.4	1.8	
		High V _{IN} to low V _{IN} OP2		0.2	0.5	
	241505	High V _{IN} to low V _{IN} OP1		1.5	2	
		High V _{IN} to low V _{IN} OP2		0.05	0.1	
	241802	High V _{IN} to low V _{IN} OP1		1.2	1.7	
		High V _{IN} to low V _{IN} OP2		0.2	0.5	

ISOLATION CHARACTERISTICS					
Parameter	Conditions	Min.	Typ.	Max.	Units
Isolation test voltage	Production tested for 1 second	6000			VDC
	Qualification tested for 1 minute	6000			VDC
Resistance	Viso= 1000VDC	1			GΩ
Continuous barrier withstand voltage				2200	VDC
External clearance	Shortest terminal-to-terminal distance through air	14			mm
External creepage	Shortest terminal-to-terminal distance across the package surface	14			mm
Working voltage	Basic (UL62368-1)			1600	Vrms
				2200	Vpk
	Reinforced (UL62368-1)			800	Vrms
				1131	Vpk
Comparative tracking index		>600			V
Material group				1	
Pollution degree				2	
Overvoltage category ¹	Rated mains voltage ≤ 300 VRMS (basic)	I		IV	
	Rated mains voltage ≤ 600 VRMS (basic)	I		III	
	Rated mains voltage ≤ 300 VRMS (reinforced)	I		III	
	Rated mains voltage ≤ 600 VRMS (reinforced)	I		II	
Operating altitude				5000	m
Transient Voltage		6000			VDC

GENERAL CHARACTERISTICS					
Parameter	Conditions	Min.	Typ.	Max.	Units
Switching frequency			700		kHz

TEMPERATURE CHARACTERISTICS					
Parameter	Conditions	Min.	Typ.	Max.	Units
Specification	All output types (see derating curves)	-40		115	°C
Storage		-40		125	
Product Temperature above ambient			10		
Cooling	Free air convection				

ABSOLUTE MAXIMUM RATINGS	
Short Circuit protection	Continuous
Input voltage V _{IN} , MGJ1D12	15V
Input voltage V _{IN} , MGJ1D15	18V
Input voltage V _{IN} , MGJ1D24	28V

1. 300Vrms system voltage includes 230/400V and 277/480V. 600Vrms system voltage includes 400/690V.

TECHNICAL NOTES

ISOLATION VOLTAGE

'Hi Pot Test', 'Flash Tested', 'Withstand Voltage', 'Proof Voltage', 'Dielectric Withstand Voltage' & 'Isolation Test Voltage' are all terms that relate to the same thing, a test voltage, applied for a specified time, across a component designed to provide electrical isolation, to verify the integrity of that isolation.

Murata Power Solutions MGJ1T series of DC-DC converters are all 100% production tested at 6kVDC for 1 second and have been qualification tested at 6kVDC for 1 minute.

A question commonly asked is, "What is the continuous voltage that can be applied across the part in normal operation?"

The MGJ1T series has been recognised by Underwriters Laboratory to 800Vrms Reinforced Insulation and 1600Vrms Basic insulation, please see safety approval section below.

REPEATED HIGH-VOLTAGE ISOLATION TESTING

It is well known that repeated high-voltage isolation testing of a barrier component can actually degrade isolation capability, to a lesser or greater degree depending on materials, construction and environment. The MGJ1T series has a proprietary block-coil transformer. While parts can be expected to withstand several times the stated test voltage, Any material is susceptible to eventual chemical degradation when subject to very high applied voltages thus implying that the number of tests should be strictly limited. We therefore strongly advise against repeated high voltage isolation testing, but if it is absolutely required, that the voltage should be reduced by 20% from specified test voltage.

This consideration equally applies to agency recognised parts rated for better than functional isolation where the insulation is always supplemented by a further insulation system of physical spacing or barriers.

SAFETY APPROVAL

UL62368-1

The MGJ1T series has been recognised by Underwriters Laboratory (UL) to UL62368-1 for reinforced insulation to a working voltage of 800Vrms and basic insulation to a working voltage of 1600Vrms.

Creepage and clearance 14mm.

FUSING

The MGJ1T Series of converters are not internally fused so to meet the requirements of UL an anti-surge input line fuse should always be used with ratings as defined below.

Input Voltage, 12V T200mA

Input Voltage, 15V T160mA

Input Voltage, 24V T100mA

All fuses should be Anti-Surge and suitably rated to meet application requirements.

RoHS COMPLIANCE, MSL, PSL AND REFLOW SOLDERING INFORMATION



This series is compatible with Pb-Free soldering systems and is also backward compatible with Sn/Pb soldering systems. The MGJ1T series can be soldered in accordance with J-STD-020 and have a classification temperature of 245°C and moisture sensitivity level 2a. termination finish on this product is ENIG with plating thickness 0.05 microns (min) as per IPC-4552.

For further information, please visit: www.murata.com/en-global/products/power/rohs

ENVIRONMENTAL VALIDATION TESTING

The following tests have been conducted on this product series, as part of our design verification process. The datasheet characteristics specify user operating conditions for this series, please contact Murata if further information about the tests is required.

Test	Standard	Condition
Temperature cycling	JEDEC JESD22-A104	1000 cycles between two temperature extremes set to achieve -40°C and +125°C. 2 full cycles per hour.
Humidity bias	JEDEC JESD22-A101	1000 hours at 85°C ±2°C, 85 ± 5% RH with continuous bias
HAST (Unbiased)	JEDEC JESD22-A118	96 hours at 130°C ±2°C, 85% ± 5% R.H.
High temperature Storage life	JEDEC JESD22-A103	1000 hours at 125°C (-0/+10)°C.
Low temperature Storage life	JEDEC JESD22-A119	1000 hours at -40°C (-10/+5)°C.
MSL	IPC/JEDEC J-STD-020	Bake samples at 125 +5/-0°C for 24 hours minimum before conditioning in the Temperature/Humidity chamber for 168 hours 60°C/60%RH.
Solderability	Based on IPC/ECA J-STD-002, Test B and B1	SnPb (Test B) For leaded solderability the parts are baked in an oven for 4 hours ±15 min. at a temperature of 155±5°C. Dipped in solder at 245°C ±5°C for 5 +0/-0.5 seconds. Pb-free (Test B1) For lead free solderability the parts are baked in an oven for 4 hours ±15 min. at a temperature of 155±5°C. Dipped in solder at 245°C ±5°C for 5 +0/-0.5 seconds.
Shock	JEDEC JESD22-B110	1500g (± 10%), 5 x 0.5ms (+/-15%) half sine pulses in each of 6 planes (± X, ± Y, ± Z) 30 pulses in total.
Vibration	JEDEC JESD22-B103	20Hz to 2 kHz to 20Hz (logarithmic variation) in >4 minutes, 4 times in each orientation (i.e. 12times), 20G (±10%) peak acceleration.
Aqueous wash	Internal reference standard	Aqueous / ultrasonic process in a suitable chemical for 30 minutes at a controlled temperature, using a water wash at low pressure with demineralised water wash at low pressure and Drying in a vacuum oven.
Resistance to cleaning agents	Internal reference standard	Step 1: Solvent washed – Novec 71IPA & Topklean EL-20A. Pulsed ultrasonic immersion Step 2: Parts rubbed with a cloth soaked with water for 15 seconds. Repeated 3 times Step 3: Tape applied across the parts printed side and then removed. Repeated 3 times Step 4: Parts rubbed with a cloth soaked with petroleum spirit for 15 seconds. Repeated 3 times.
ESD	ANSI/ESDA/JEDEC JS-001	HBM Testing Standard at 3 stress levels; 2kV, 4kV and 8kV
	ANSI/ESDA/JEDEC JS-002	CDM Testing Standard at 5 stress levels; 500V, 750V, 1000V, 1500V and 2000V.

PART NUMBER STRUCTURE

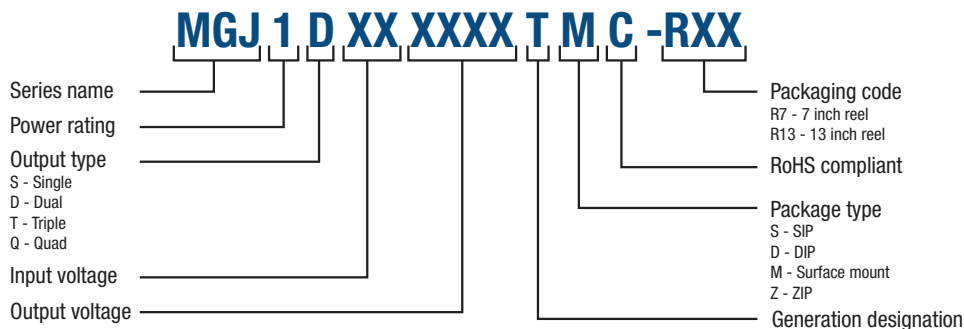

CHARACTERISATION TEST METHODS

Ripple & Noise Characterisation Method

Ripple and noise measurements are performed with the following test configuration.

C1	1 μ F X7R multilayer ceramic capacitor, voltage rating to be a minimum of 3 times the output voltage of the DC-DC converter
C2	10 μ F tantalum capacitor, voltage rating to be a minimum of 1.5 times the output voltage of the DC-DC converter with an ESR of less than 100m Ω at 100 kHz
C3	100nF multilayer ceramic capacitor, general purpose
R1	450 Ω resistor, carbon film, \pm 1% tolerance
R2	50 Ω BNC termination
T1	3T of the coax cable through a ferrite toroid
RLOAD	Resistive load to the maximum power rating of the DC-DC converter. Connections should be made via twisted wires

Measured values are multiplied by 10 to obtain the specified values.

Differential Mode Noise Test Schematic

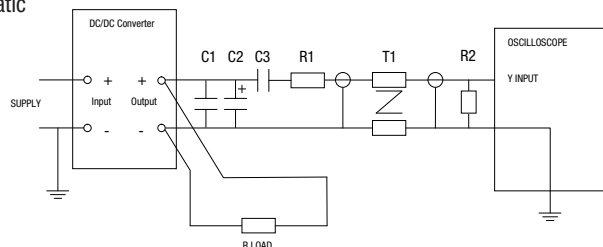

APPLICATION NOTES

Minimum load

The minimum load to meet datasheet specification is 10% of the full rated load across the specified input voltage range. Lower than 10% minimum loading will result in an increase in output voltage, which may rise to typically 1.25 times the specified output voltage if the output load falls to less than 5%.

Gate Drive Applications Advisory Note

For general guidance for product usage in gate drive applications please refer to "[gate drive application notes](#)".

Capacitive loading and start up

Typical start up times for this series, with a typical input voltage rise time of 40ms and output capacitance of 10 μ F, are shown in the table below. The product series will start into capacitance ranging up to 470 μ F with increased start times.

	Start-up time
	ms
MGJ1DXXXXXTMC	40

Typical Start-Up Wave Form

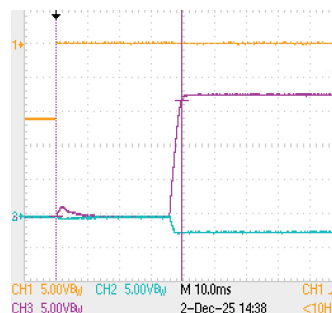

APPLICATION NOTES (Continued)

High voltage DC motor drive using SiC MOSFETS

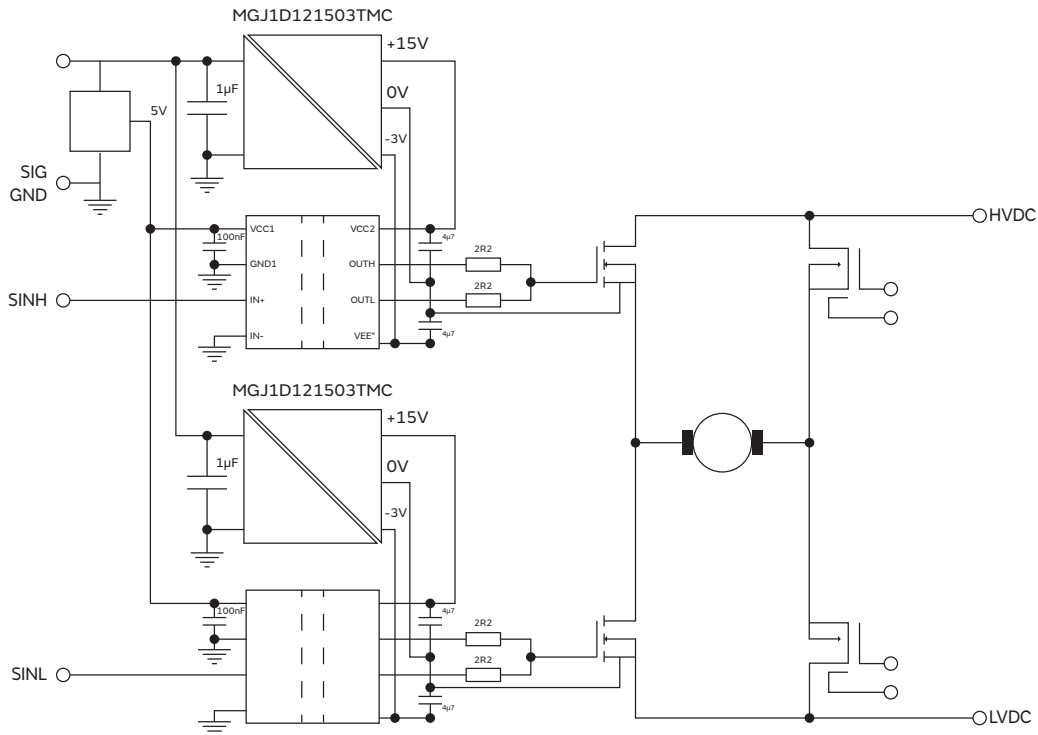

High voltage to 3-phase inverter (HS only)

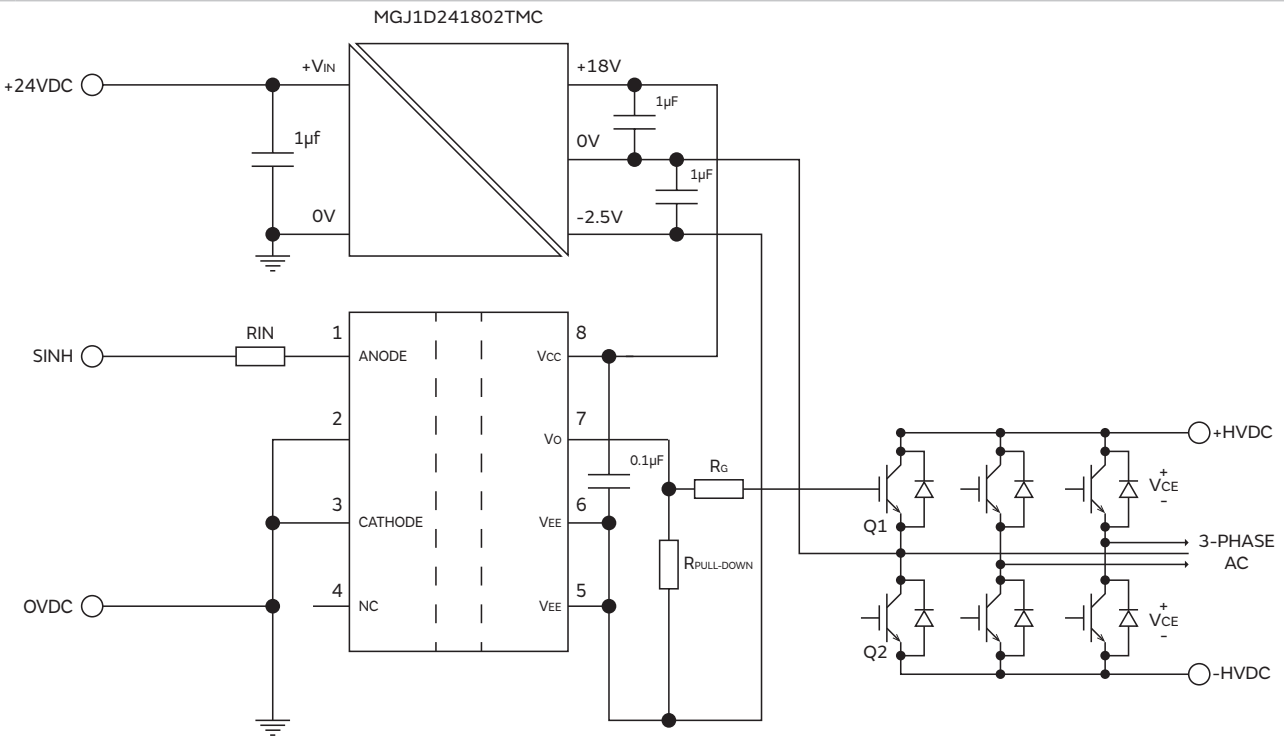

APPLICATION NOTES (Continued)

Single sided (Low) induction heater

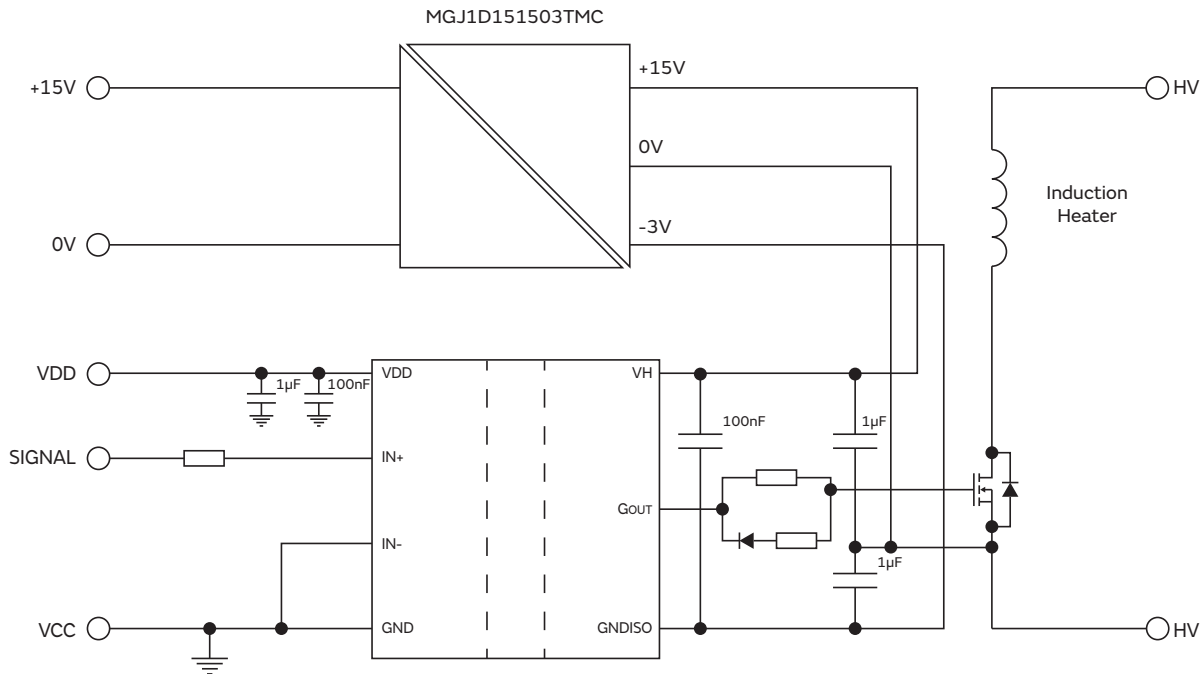

Connections for driving MOSFET devices

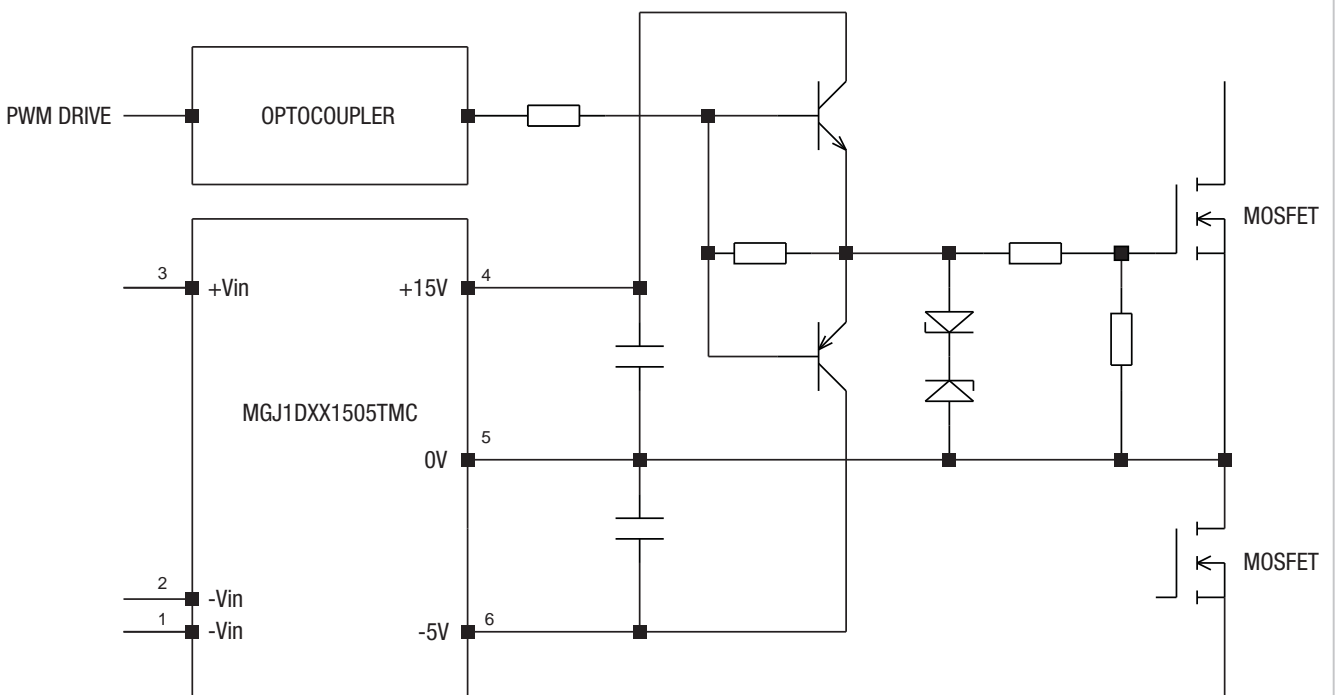

POSITIVE OUTPUT VOLTAGE TOLERANCE ENVELOPES

The voltage tolerance envelopes show typical load regulation characteristics for this product series. The tolerance envelope is the maximum output voltage variation due to changes in output loading and set point accuracy.

MGJ1D121503TMC

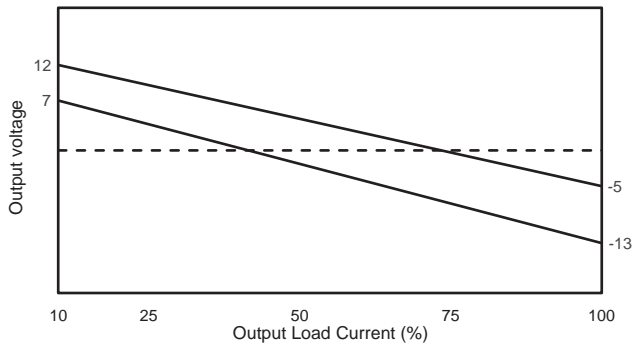

MGJ1D121505TMC

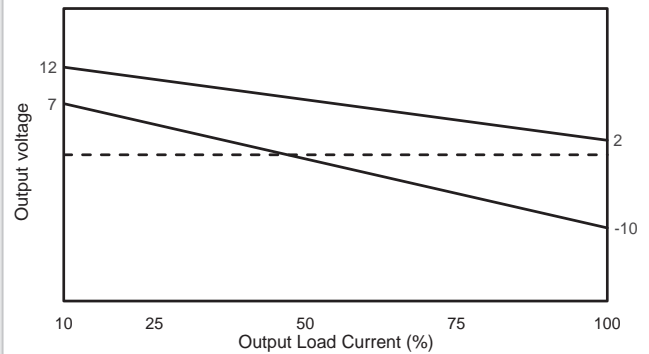

MGJ1D121802TMC

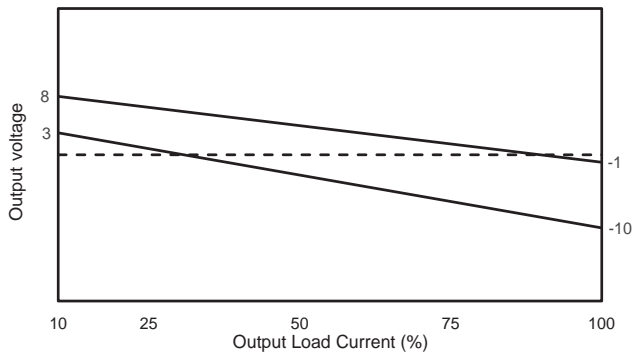

MGJ1D151503TMC

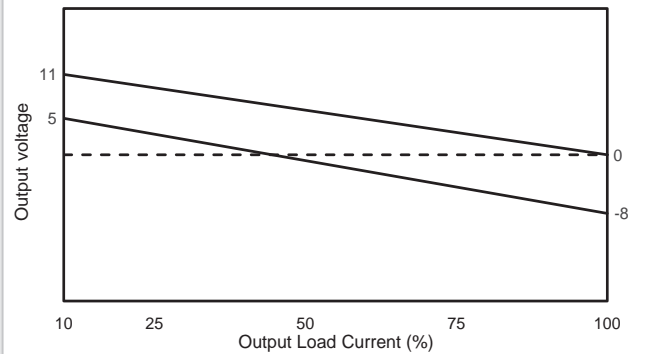

MGJ1D151802TMC

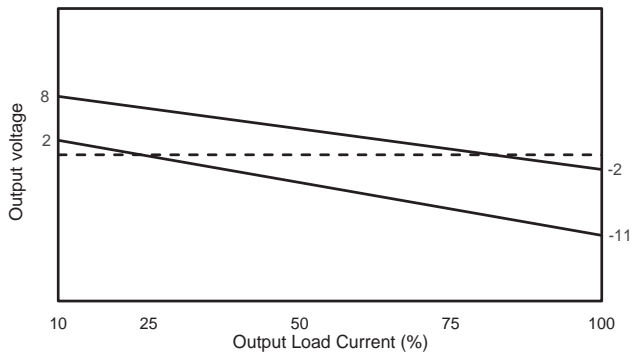

MGJ1D241503TMC

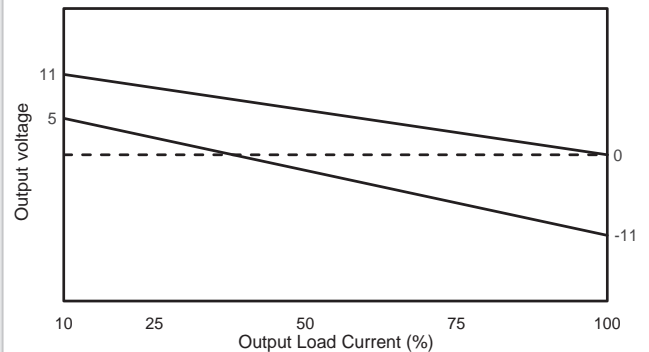

POSITIVE OUTPUT VOLTAGE TOLERANCE ENVELOPES (Continued)

MGJ1D241505TMC

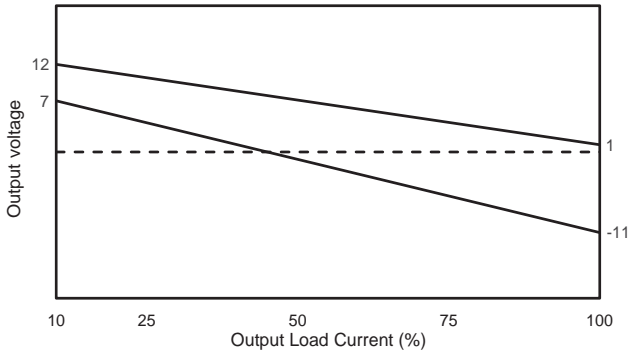

MGJ1D241802TMC

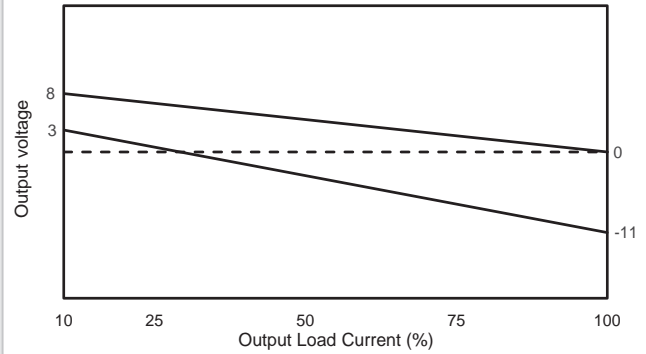

NEGATIVE OUTPUT VOLTAGE TOLERANCE ENVELOPES

MGJ1D121503TMC

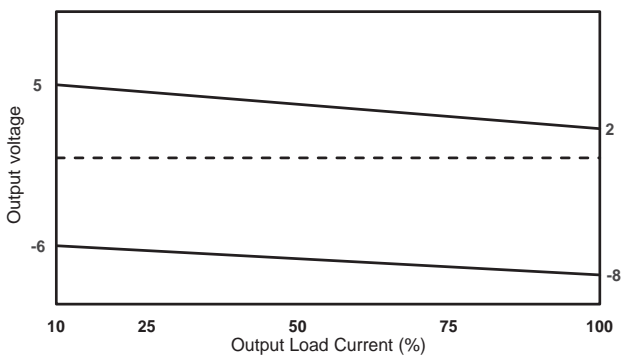

MGJ1D121505TMC

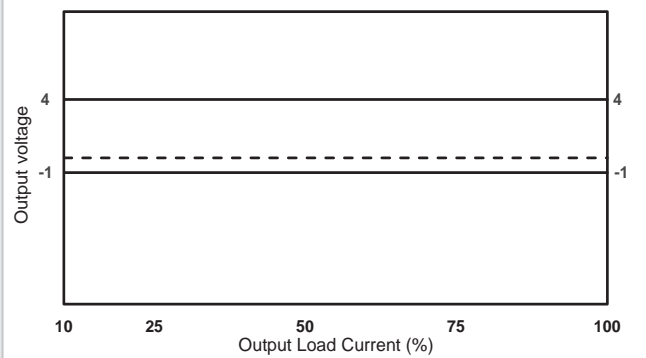

MGJ1D121802TMC

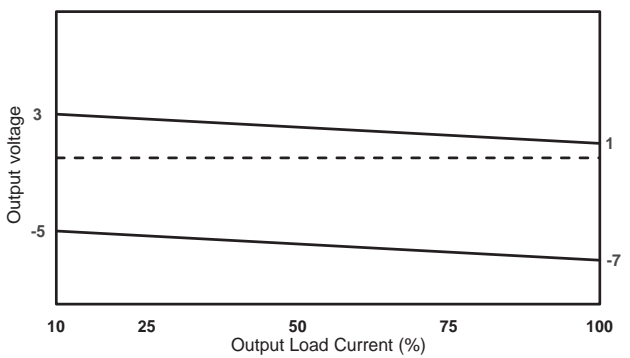

MGJ1D151503TMC

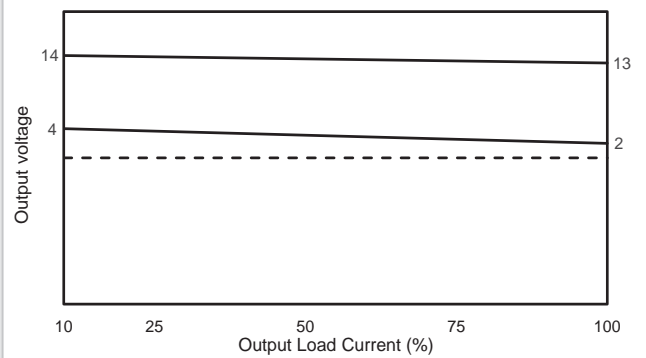

NEGATIVE OUTPUT VOLTAGE TOLERANCE ENVELOPES

MGJ1D151802TMC

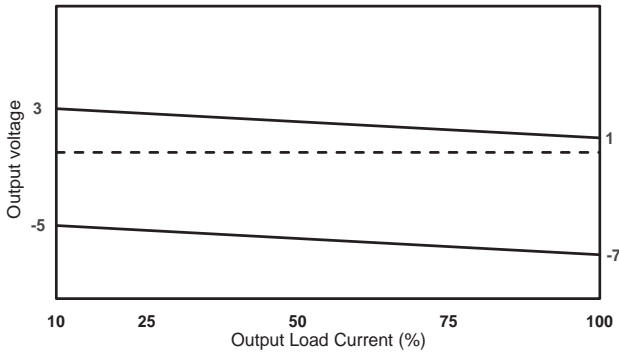

MGJ1D241503TMC

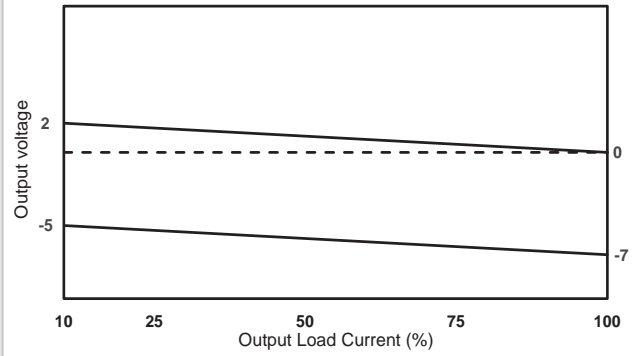

MGJ1D241505TMC

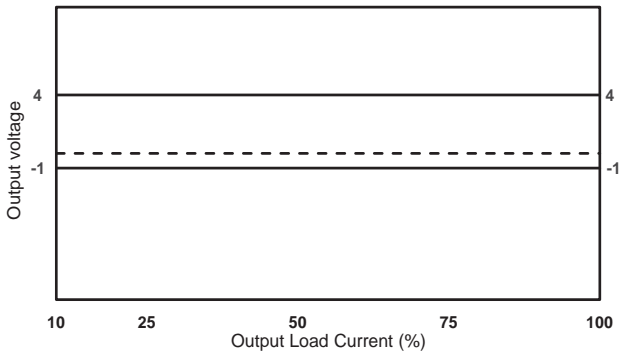

MGJ1D241802TMC

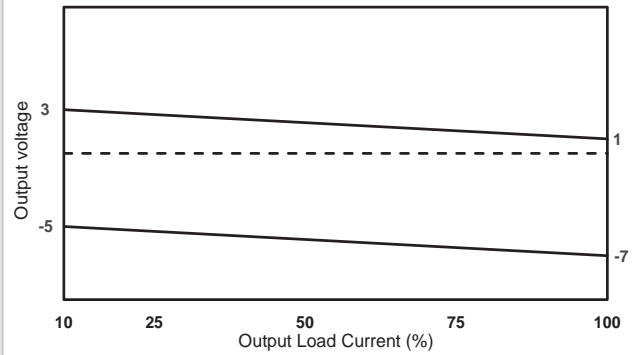

EFFICIENCY VS LOAD

MGJ1D121503TMC

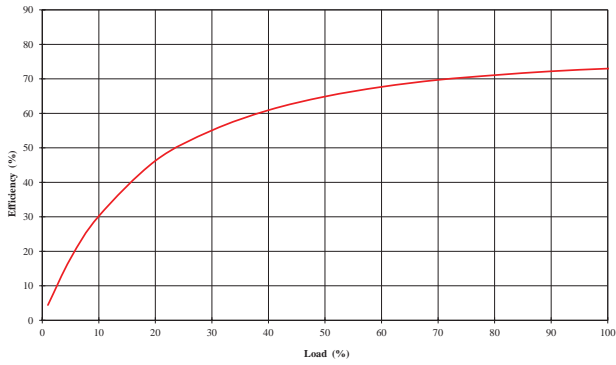

MGJ1D121505TMC

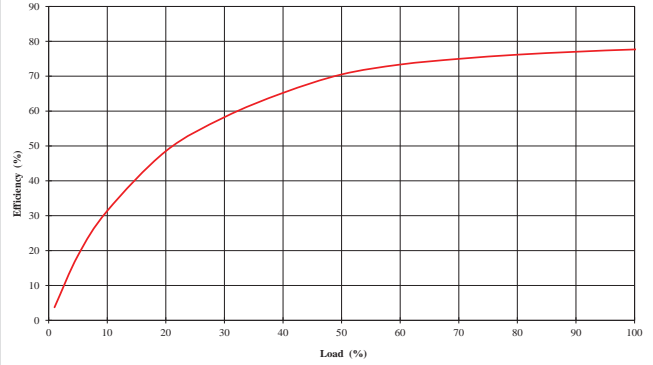

MGJ1D121802TMC

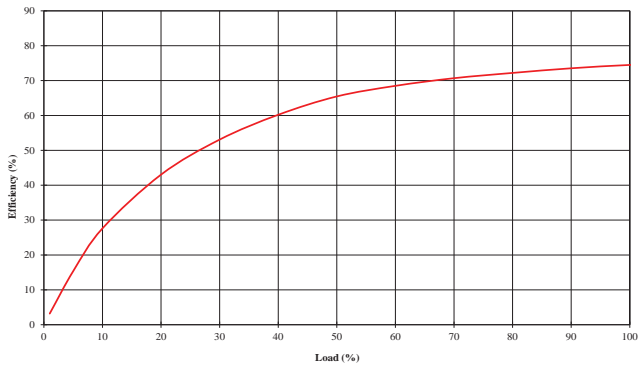

MGJ1D151503TMC

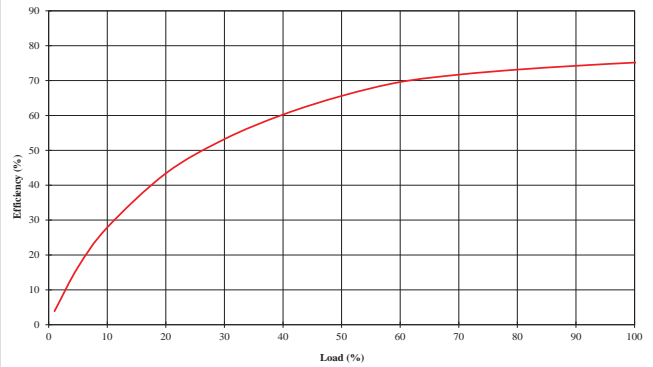

MGJ1D151802TMC

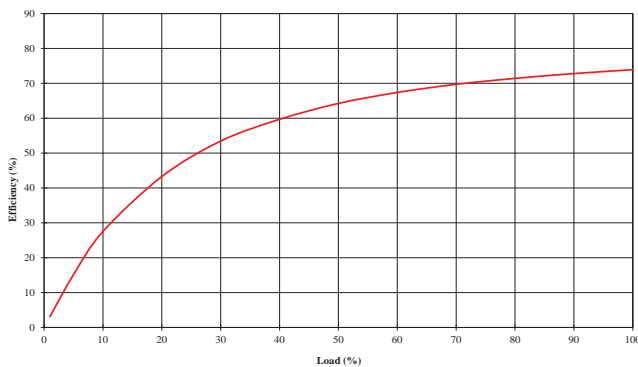

MGJ1D241503TMC

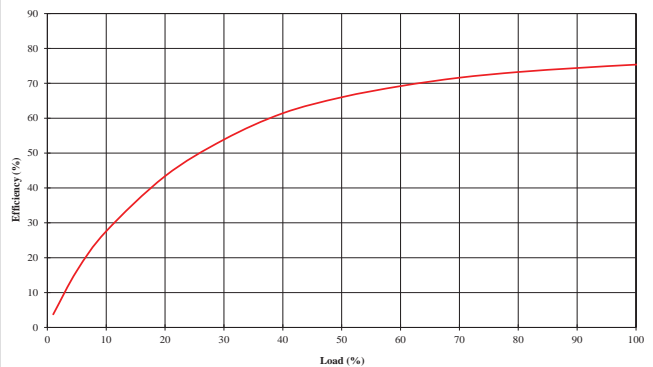

EFFICIENCY VS LOAD (Continued)

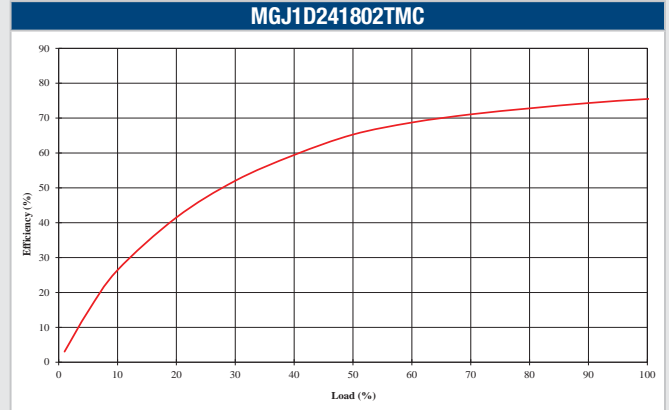
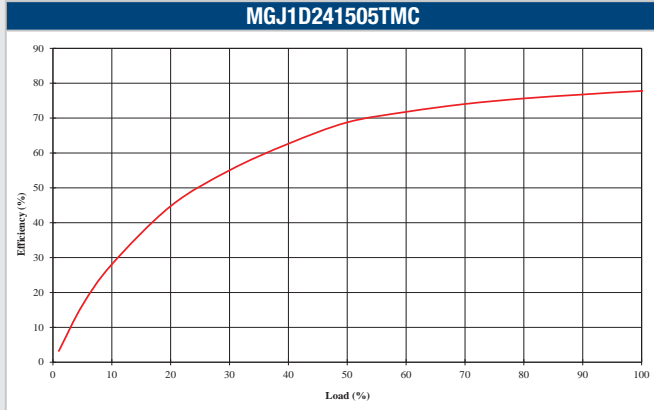

TEMPERATURE DERATING GRAPH

The MGJ1T series has been designed to minimise the thermal impedance when mounted onto a customers application PCB by using multiple surface mount pads for each connection. All thermal measurements were carried out in still air using a test pcb designed in accordance with standard JESD51-9 (Test Boards for Area Array Surface Mount Package Thermal Measurements). A 4 layer PCB has been used and this demonstrates that a higher operating temperature can be achieved when the customers application pcb is designed to incorporate multiple layers and large copper planes. Please contact Murata for further information.

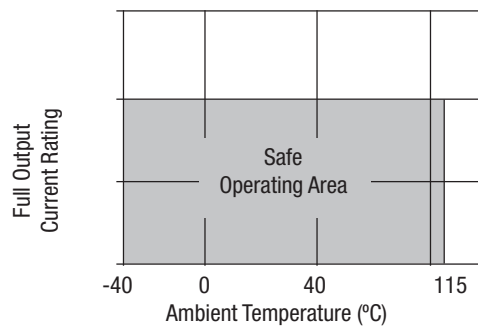

PACKAGE SPECIFICATIONS

Mechanical Dimensions

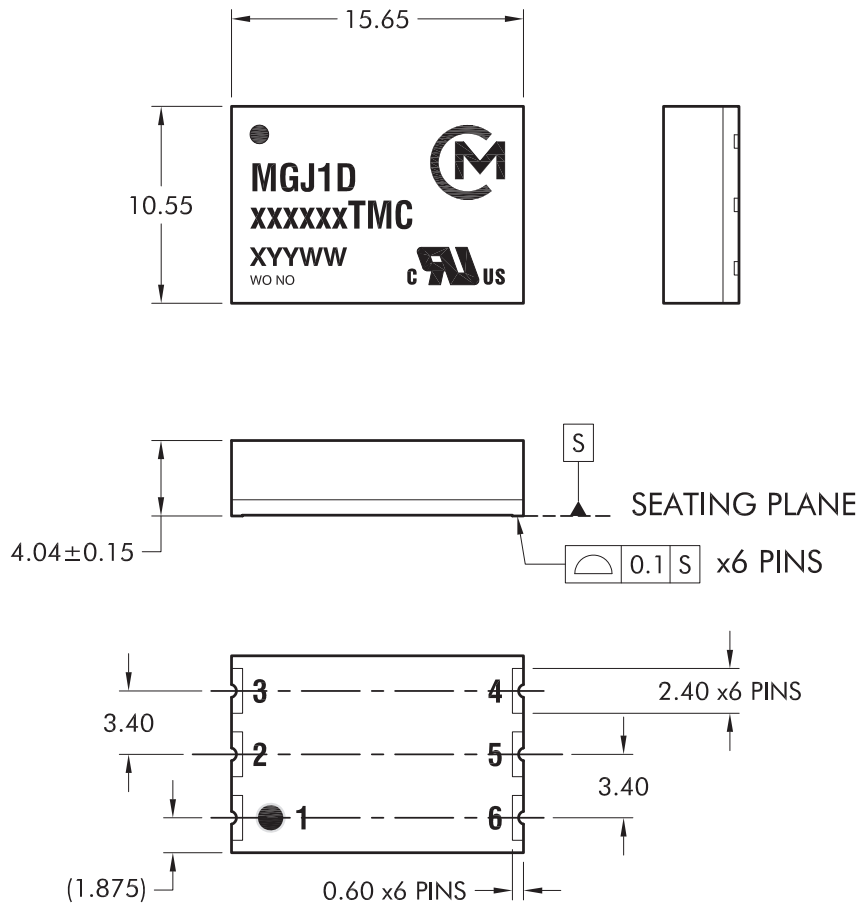

All dimensions in mm. Tolerances (unless otherwise stated) ±0.1.

Weight: 1.6g

Pin Connections

Pin	Function
1	-Vin
2	-Vin
3	+Vin
4	+Vout
5	0V
6	-Vout

Recommended Footprint Details

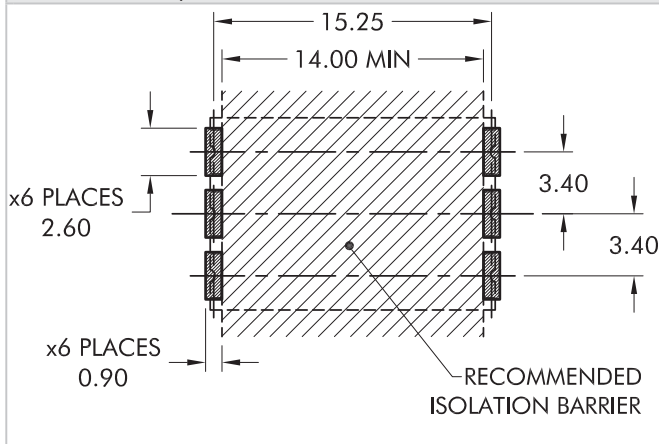

TAPE & REEL SPECIFICATIONS

REEL OUTLINE DIMENSIONS

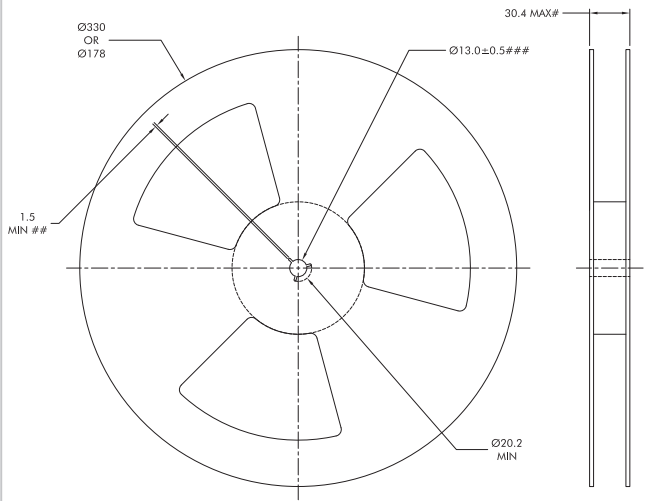

All dimensions in mm.
Measured at hub
Six equi-spaced slots on 178mm reel
13.5±0.3mm on 178mm reel

REEL PACKAGING DETAILS

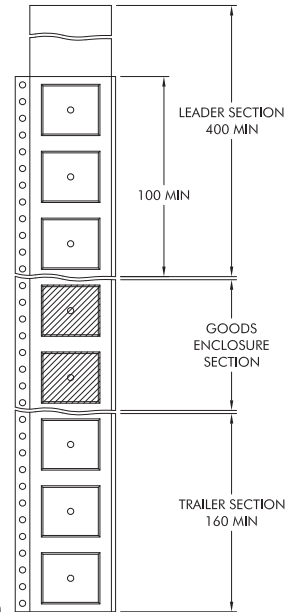

Reel Quantity: 7" - 160 or 13" - 710
Carrier tape pockets shown are illustrative only - refer to carrier tape diagram for actual pocket details

TAPE OUTLINE DIMENSIONS

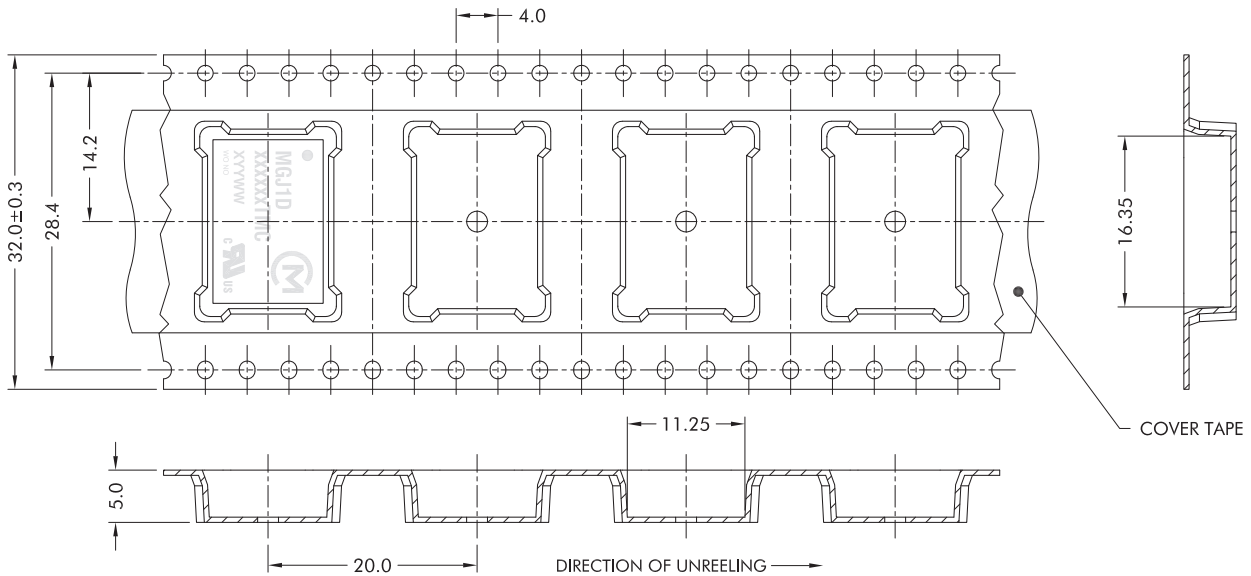

Carrier tape specification shall conform with current eia-481 standard
Unless otherwise stated all dimensions in mm±0.1 mm.
Components shall be orientated within the carrier tape as indicated

DISCLAIMER

Unless otherwise stated in the datasheet, all products are designed for standard commercial and industrial applications and NOT for safety-critical and/or life-critical applications.

Particularly for safety-critical and/or life-critical applications, i.e. applications that may directly endanger or cause the loss of life, inflict bodily harm and/or loss or severe damage to equipment/property, and severely harm the environment, a prior explicit written approval from Murata is strictly required. Any use of Murata standard products for any safety-critical, life-critical or any related applications without any prior explicit written approval from Murata shall be deemed unauthorised use.

These applications include but are not limited to:

- Aircraft equipment
- Aerospace equipment
- Undersea equipment
- Power plant control equipment
- Medical equipment
- Transportation equipment (automobiles, trains, ships, etc.)
- Traffic signal equipment
- Disaster prevention / crime prevention equipment
- Data Processing equipment

Murata makes no express or implied warranty, representation, or guarantee of suitability, fitness for any particular use/purpose and/or compatibility with any application or device of the buyer, nor does Murata assume any liability whatsoever arising out of unauthorised use of any Murata product for the application of the buyer. The suitability, fitness for any particular use/purpose and/or compatibility of Murata product with any application or device of the buyer remain to be the responsibility and liability of the buyer.

Buyer represents and agrees that it has all the necessary expertise to create and implement safeguards that anticipate dangerous consequences of failures, monitor failures and their consequences, lessen the likelihood of failures that might cause harm, and take appropriate remedial actions. Buyer will fully indemnify and hold Murata, its affiliated companies, and its representatives harmless against any damages arising out of unauthorised use of any Murata products in any safety-critical and/or life-critical applications.

Remark: Murata in this section refers to Murata Manufacturing Company and its affiliated companies worldwide including, but not limited to, Murata Power Solutions.



This product is subject to the following [operating requirements](#) and the [Life and Safety Critical Application Sales Policy](#):

Refer to: <https://www.murata.com/en-eu/products/power/requirements>

Murata Power Solutions (Milton Keynes) Ltd. makes no representation that the use of its products in the circuits described herein, or the use of other technical information contained herein, will not infringe upon existing or future patent rights. The descriptions contained herein do not imply the granting of licenses to make, use, or sell equipment constructed in accordance therewith. Specifications are subject to change without notice.
© 2026 Murata Power Solutions (Milton Keynes) Ltd.