

Typical unit

**FEATURES**

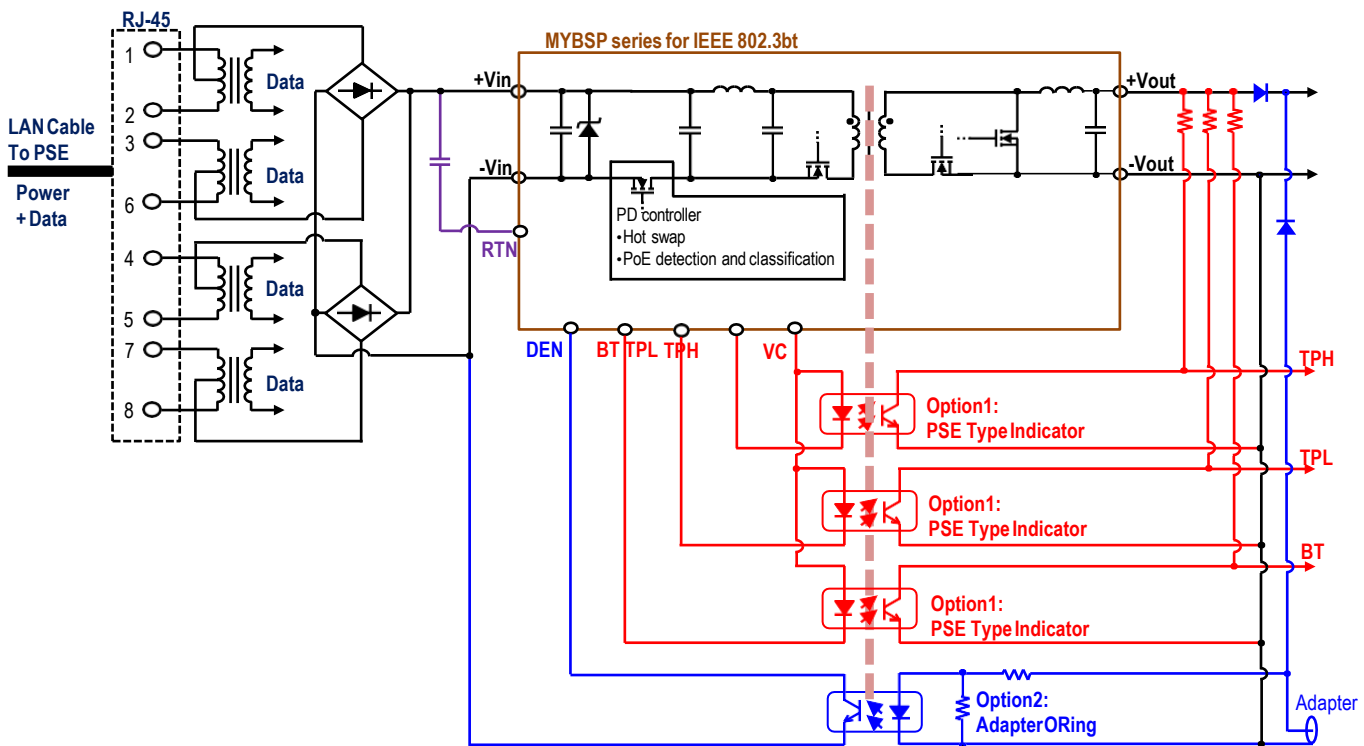
- 51W DC-DC converter with supporting IEEE802.3bt class6 (MYBSP0124CAZFT)
- 72W DC-DC converter with supporting IEEE802.3bt class8 (MYBSP01206AZFT)
- Support PSE Type Indicators
- Support Adapter ORing
- 41.1-57V Input Voltage range
- 22.2 x 56.4 x 8.57mm Size
- 92.8% efficiency (typical) (MYBSP0124CAZFT)
- 93.2% efficiency (typical) (MYBSP01206AZFT)
- 2250V Input-Output Isolation
- Operating Temperature range -40 to 85degC

**PRODUCT OVERVIEW**

MYBSP0124CAZFT and MYBSP01206AZFT are isolated, regulated, DC-DC converters for PoE Powered Devices (PD), featuring an input range of 41.1 to 57V, high efficiency and 2250 Volt DC isolation. The products are designed for IEEE 802.3bt compliant applications.

The products have detection and classification for IEEE 802.3bt compliant, Power Sourcing Equipment (PSE) type Indicator function, and Adapter ORing function.

The modules include self-protection features such as input undervoltage lockout, output current limit, output overvoltage protection and overtemperature protection. The output current limit uses the hiccup auto-restart technique.



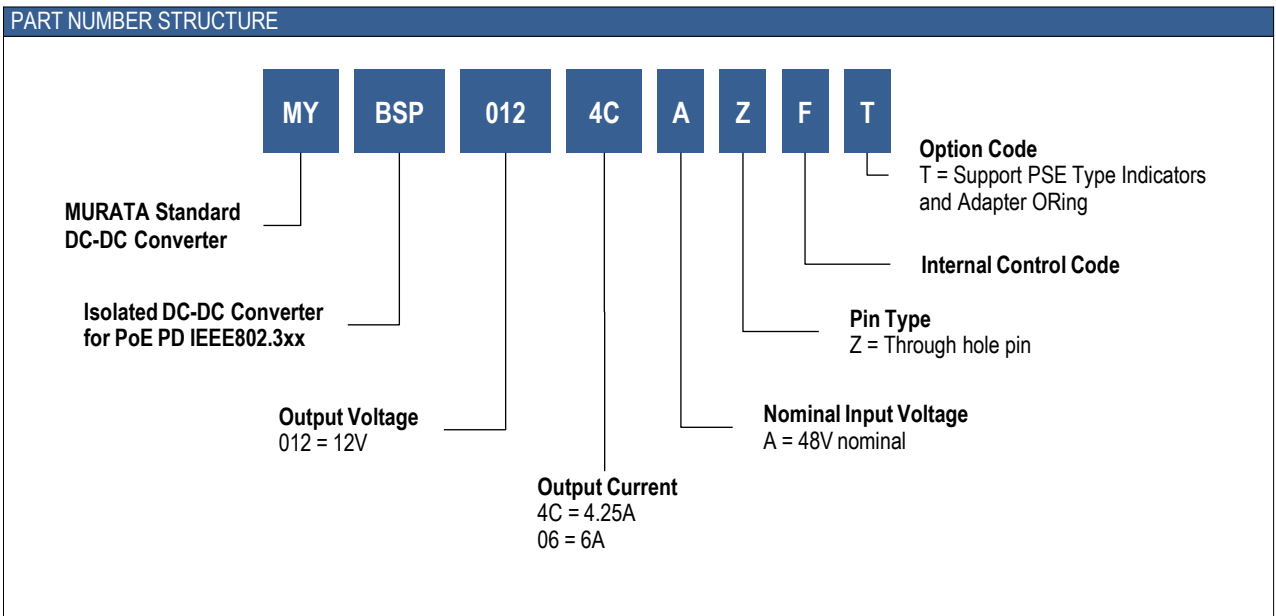
Typical topology is shown.  
**Figure 1. Simplified Block Diagram**

**Table 1. Performance Specifications Summary and Ordering Information**

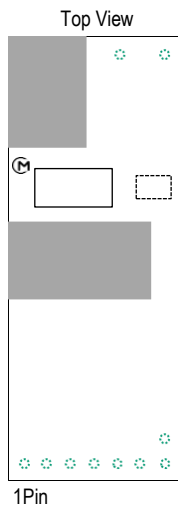
PERFORMANCE SPECIFICATIONS SUMMARY AND ORDERING GUIDE													
Model Number	Output					Input					Efficiency [%]		Package [mm]
	Vout [V]	Iout [A] (Max.)	Power [W]	R/N [mVp-p] (Typ.)	Regulation (Typ.)		Vin [V] (Nom.)	Range [V]	Iin, no load [mA](Typ.)	Iin, full load [A](Typ.)	(Min.)	(Typ.)	
					Line [%]	Load [%]							
MYBSP0124CAZFT	12	4.25	51	100	±0.1	±0.1	48	41.1-57	44.7	1.14	90.5	92.8	22.2 x 56.4 x 8.57
MYBSP01206AZFT	12	6	72	100	±0.1	±0.1	48	41.1-57	54.0	1.61	91	93.2	22.2 x 56.4 x 8.57

1. Please refer to the Part Number Structure for additional ordering information and options.
2. All specifications are at nominal line voltage, full load, 25degC unless otherwise stated.

**Table 2. Part Numbering**



**Product Marking**



- Codes**
- Ⓜ Murata Manufacturing ID
  - Model Number
  - Internal Manufacturing Code

PART NUMBER	MODEL NUMBER
MYBSP0124CAZFT	MYBSP0124CAZFT
MYBSP01206AZFT	MYBSP01206AZFT

**Figure 2. Top Marking Specification**

**FUNCTIONAL SPECIFICATIONS, MYBSP0124CAZFT, MYBSP01206AZFT**

**Table 3. Functional Specifications**

ABSOLUTE MAXIMUM RATINGS	Conditions	Minimum	Typical / Nominal	Maximum	Units
Input Voltage, Continuous		0		57	V
Input Voltage, Transient	100ms max. duration			60	V
Isolation Voltage	Input to output, Leak current 1mAmax for 1minute at 25degC/60%RH.			2250	V
Output Power	MYBSP0124CAZFT	0		51	W
	MYBSP01206AZFT*1	0		72	
Output Current	MYBSP0124CAZFT	0		4.25	A
	MYBSP01206AZFT	0		6	
Storage Temperature Range	Vin = Zero (no power)	-40		90	degC
Absolute maximums are stress ratings. Exposure of devices to greater than any of these conditions may adversely affect long-term reliability. Proper operation under conditions other than those listed in the Performance/Functional Specifications Table is not implied or recommended.					
<b>INPUT</b>					
Operating Voltage Range		41.1	48	57	V
Start-up threshold	Rising input voltage	36.1		40.2	V
Under voltage shutdown	Falling input voltage	MYBSP0124CAZFT		35.3	V
		MYBSP01206AZFT	30.3	33.8	
Internal Filter Type			Pi		
<b>Input current</b>					
Full Load Conditions	Vin = nom., Iout = max.	MYBSP0124CAZFT		1.14	A
		MYBSP01206AZFT		1.61	
Low Line Input current	Vin = min., Iout = max. Vin = min., Iout = 5.85A	MYBSP0124CAZFT		1.35	A
		MYBSP01206AZFT*1		1.85	
No Load Current	Vin = nom., Iout = 0A	MYBSP0124CAZFT		44.7	mA
		MYBSP01206AZFT		54.0	
Current Limit Inception		MYBSP0124CAZFT	1.55		A
		MYBSP01206AZFT*1	1.9		
On Resistance of Internal Hotswap		MYBSP0124CAZFT		0.3	Ω
		MYBSP01206AZFT		0.1	
Resistance for detection	Vin=2.7 to 10.1V			24.9	kΩ
Classification current A	Vin=14.5 to 20.5V			39.9	mA
Classification current B	Same as above	MYBSP0124CAZFT		10.6	mA
		MYBSP01206AZFT		27.9	
Maximum Capacitive Loading	Added between positive input (+ Vin) and RTN	0		100	uF
<b>GENERAL and SAFETY</b>					
Efficiency	Vin = 48V, full load	MYBSP0124CAZFT	90.5	92.8	%
		MYBSP01206AZFT	91	93.2	
<b>Isolation</b>					
Isolation Voltage	Input to output, Leak current 1mAmax for 1minute at 25degC/60%RH.	2250			V
Insulation Safety Rating			Functional		
Isolation Capacitance			1500		pF
Calculated MTBF	Telcordia SR-332, issue 1, class 3, ground fixed, Ta = 25degC		1265		Hours x 10 <sup>3</sup>

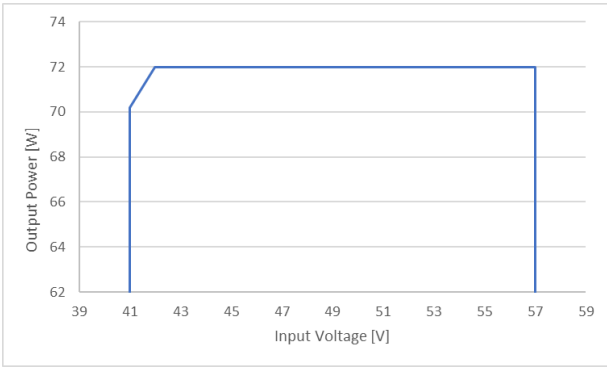
**FUNCTIONAL SPECIFICATIONS, MYBSP0124CAZFT, MYBSP01206AZFT**

DYNAMIC CHARACTERISTIC						
Fixed Switching Frequency			410		kHz	
Vout Rise Time	From 10%-90% of Vout		1		ms	
Dynamic Load Response	50-100-50% load step to 1% of Vout	MYBSP0124CAZFT	300		uSec	
		MYBSP01206AZFT	400			
Dynamic Load Peak Deviation	same as above	MYBSP0124CAZFT	±100		mV	
		MYBSP01206AZFT	±150			
OUTPUT	Conditions	Minimum	Typical / Nominal	Maximum	Units	
Total Output Power	MYBSP0124CAZFT	0		51	W	
	MYBSP01206AZFT	0		72		
Voltage						
Nominal Output Voltage	all conditions	MYBSP0124CAZFT MYBSP01206AZFT	11.64	12	12.36	V
Overvoltage Protection		MYBSP0124CAZFT MYBSP01206AZFT	14.4			V
Current						
Output Current Range*2		MYBSP0124CAZFT	0		4.25	A
		MYBSP01206AZFT	0		6	
Current Limit Inception		MYBSP0124CAZFT	4.38			A
		MYBSP01206AZFT	6.18			
Protection method		Hiccup current limiting		Non-latching		
Regulation						
Line Regulation	Vin= min. to max., Vout= nom., full load			±0.1		% of Vout
Load Regulation	Iout = min. to max.			±0.1		% of Vout
Ripple and Noise	150 MHz BW, Cout=10uF MLCC paralleled with 0.1uF			100		mV pk-pk
Temperature Coefficient	At all outputs			±0.02		% of Vout/degC
Maximum Capacitive Loading	Low ESR	MYBSP0124CAZFT	0		100	uF
		MYBSP01206AZFT	0		200	
BT / TPL / TPH / VC / DEN						
BT / TPL / TPH						
Sinking Current	After classification, BT / TPL / TPH connect to VC			1.7		mA
VC						
Output Voltage	After start up			11	12.36	V
DEN						
Output Voltage	DEN=open				+Vin	V
Output Current	DEN connect to -Vin				5	mA
Disable Voltage	Falling				2.8	V
MECHANICAL						
Outline Dimensions	L x W x H			22.2 x 56.4 x 8.57		mm
Weight				21		Grams
Pin Diameter				1.02 & 1.57		mm
Pin Material				Copper alloy		
ENVIRONMENTAL						
Operating Ambient Temperature Range			-40		85	degC
Thermal Protection/Shutdown	Measured at hotspot			135		degC
Electromagnetic Interference Conducted, EN55032/CISPR32	External filter is required			A		Class
Electromagnetic Interference Radiated, EN55032/CISPR32	External filter is required			B		Class

**Specification Notes**

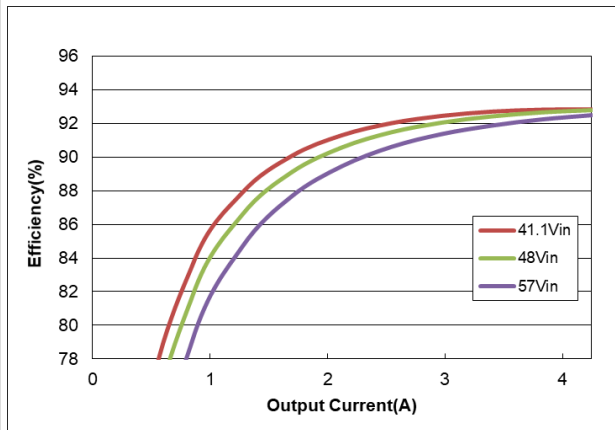
Unless otherwise noted, all specifications are typical at nominal input voltage, nominal output voltage and full load. General conditions are 25degC ambient temperature, near sea level altitude, natural convection airflow. All models are tested and specified with external parallel 10uF and 0.1uF output capacitors (See Technical Notes).

\*1 Input current overcurrent protection limits output power at low input voltage.  
Refer to the following graph for input voltage vs. output power.



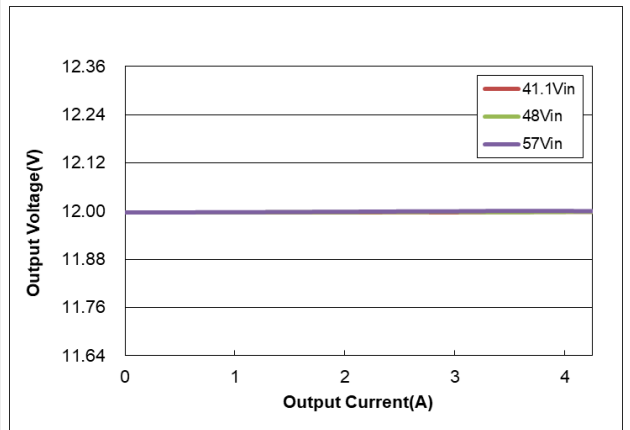
\*2 Input current must be greater than or equal to 16mA if your application applies Maintain Power Signature(MPS) by IEEE802.3bt. Please check with your application.

PERFORMANCE DATA, MYBSP0124CAZFT



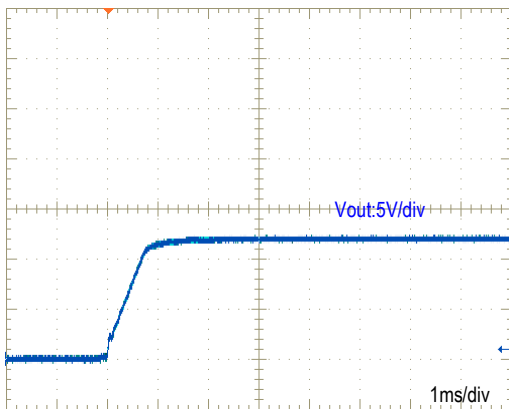
(Ta = 25degC)

**Figure 3. Efficiency vs. Line Voltage and Load Current**



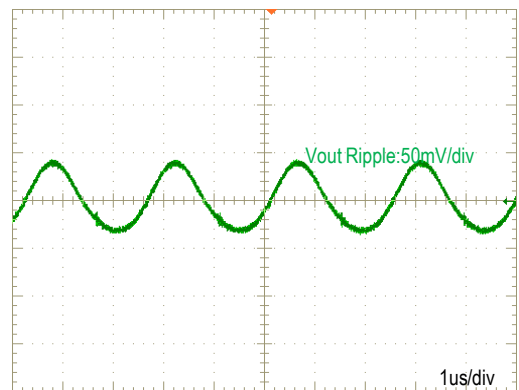
(Ta = 25degC)

**Figure 4. Load Regulation**



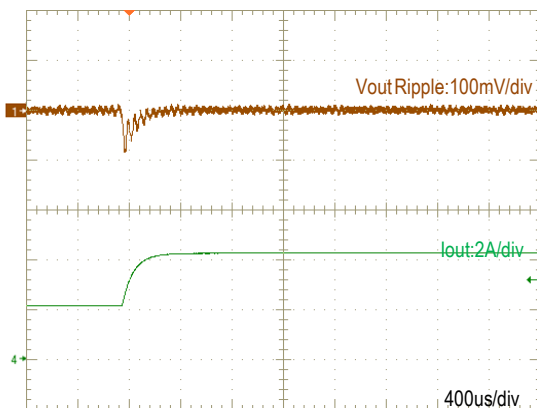
(VIN = 48V, IOUT = 4.25A, Ta = 25degC)

**Figure 5. Vout Start-up**



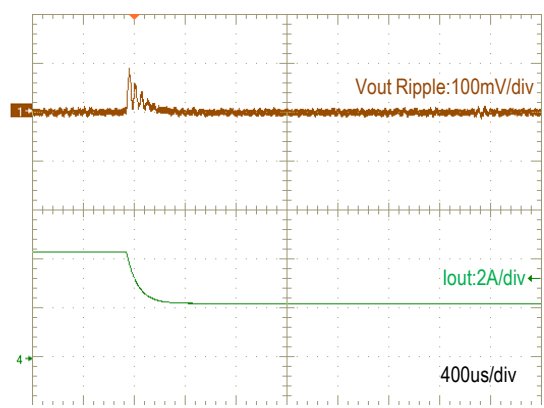
(VIN = 48V, IOUT = 4.25A, Ta = 25degC)

**Figure 6. Output Ripple and Noise**



(VIN = 48V, IOUT = 2.13 to 4.25A, Ta = 25degC)

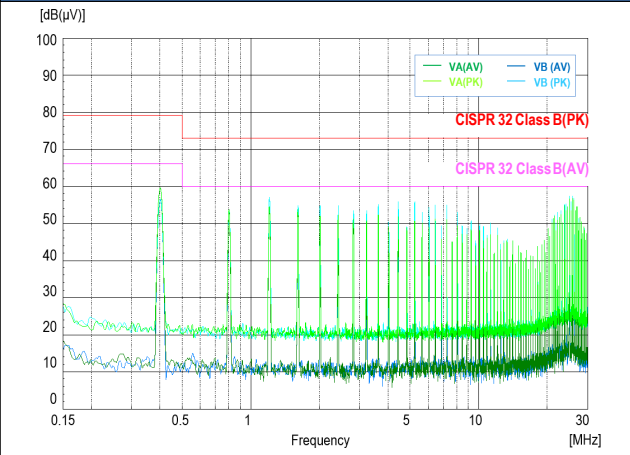
**Figure 7. Transient Response**



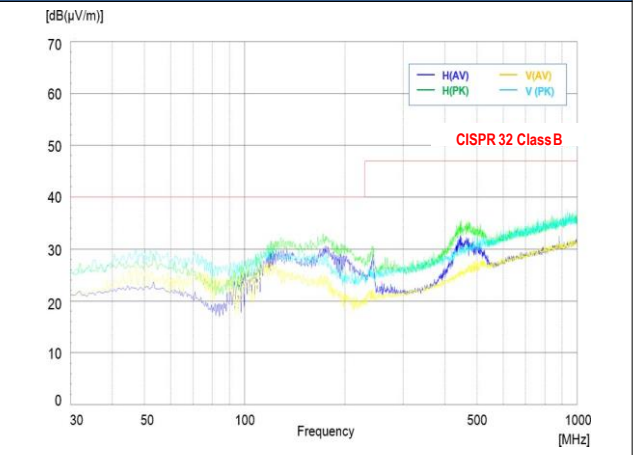
(VIN = 48V, IOUT = 4.25 to 2.13A, Ta = 25degC)

**Figure 8. Transient Response**

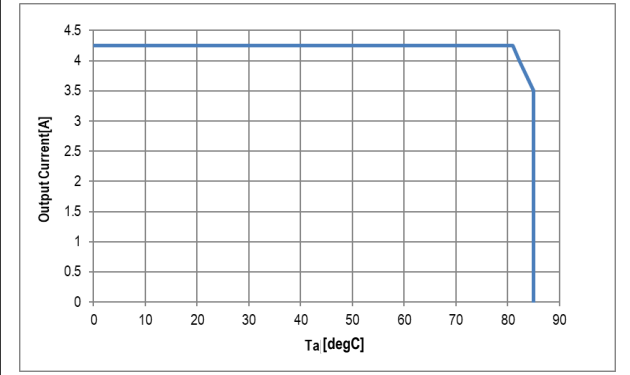
PERFORMANCE DATA, MYBSP0124CAZFT



( $V_{IN} = 48V$ ,  $I_{OUT} = 4.25A$ ,  $T_a = 25degC$ ) with External Input Filter  
**Figure 9. Conduction Noise**

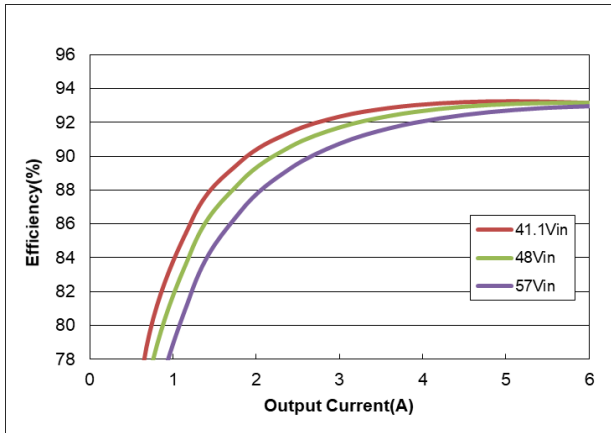


( $V_{IN} = 48V$ ,  $I_{OUT} = 4.25A$ ,  $T_a = 25degC$ ) with External Input Filter  
**Figure 10. Radiation Noise**



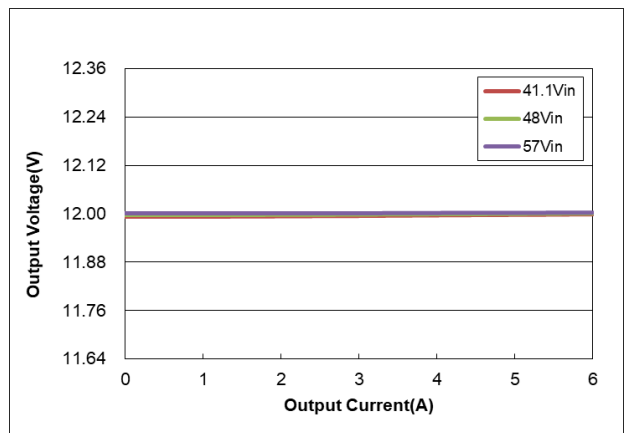
Unit under test (UUT) is covered by acrylic box to avoid airflow.  
( $V_{IN} = 48V$ , See [Technical Notes](#))  
**Figure 11. Thermal Derating**

PERFORMANCE DATA, MYBSP01206AZFT



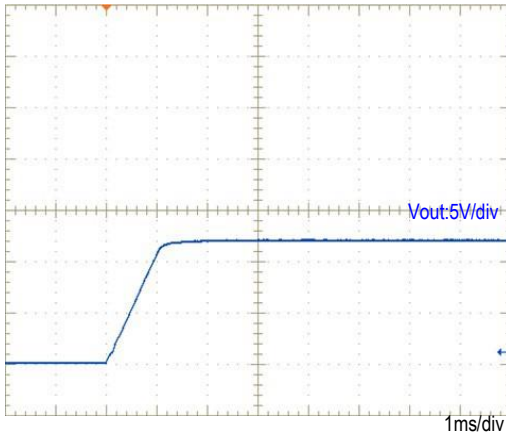
(Ta = 25degC)

**Figure 12. Efficiency vs. Line Voltage and Load Current**



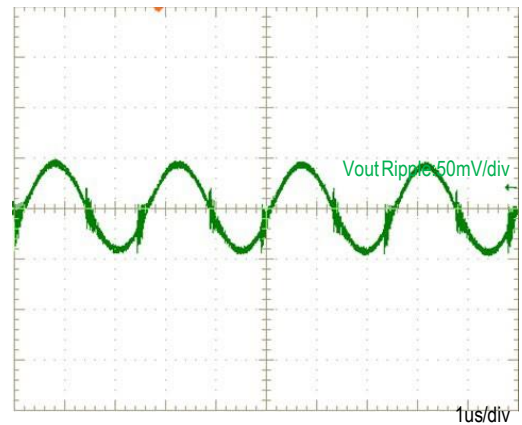
(Ta = 25degC)

**Figure 13. Load Regulation**



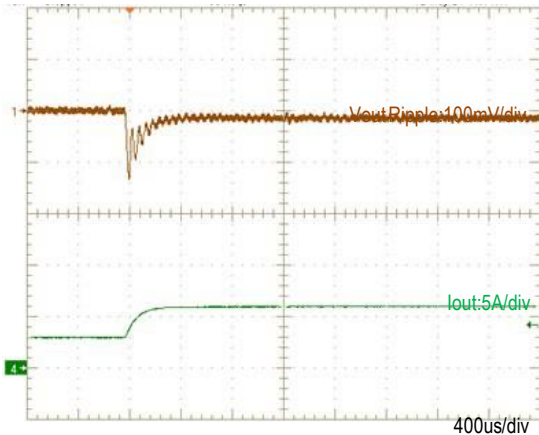
(VIN = 48V, IOUT = 6A, Ta = 25degC)

**Figure 14. Vout Start-up**



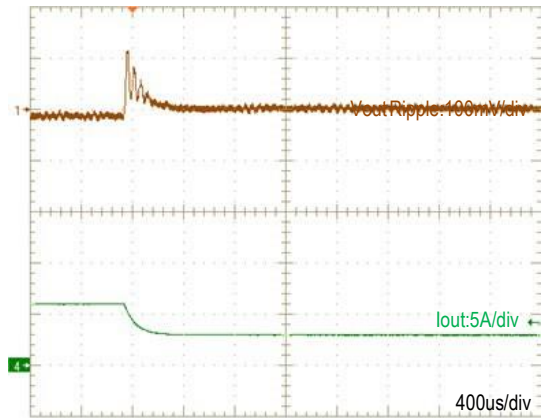
(VIN = 48V, IOUT = 6A, Ta = 25degC)

**Figure 15. Output Ripple and Noise**



(VIN = 48V, IOUT = 3 to 6A, Ta = 25degC)

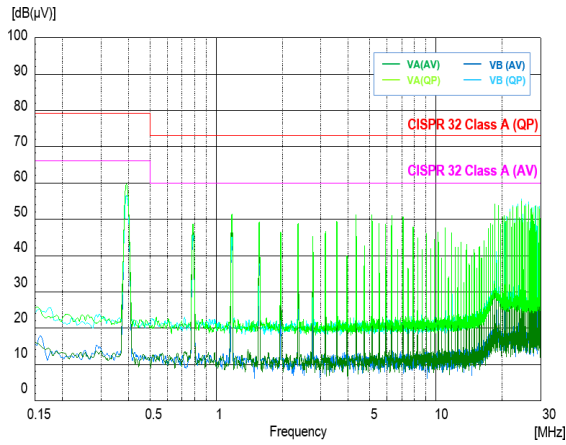
**Figure 16. Transient Response**



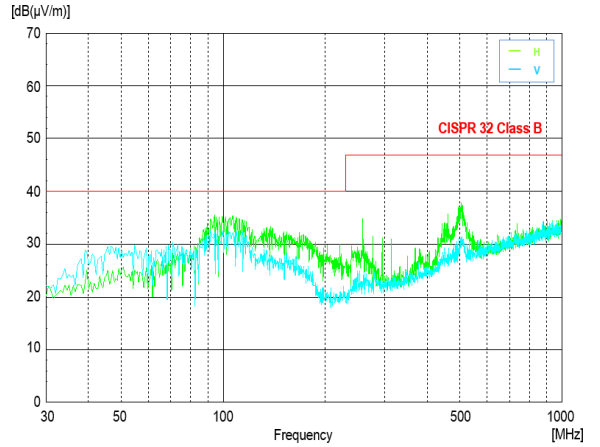
(VIN = 48V, IOUT = 6 to 3A, Ta = 25degC)

**Figure 17. Transient Response**

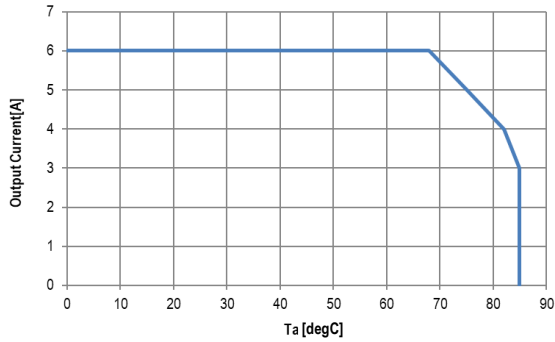
PERFORMANCE DATA, MYBSP01206AZFT(CONT.)



( $V_{IN} = 48V$ ,  $I_{OUT} = 6A$ ,  $T_a = 25degC$ ) with External Input Filter  
**Figure 18. Conduction Noise**



( $V_{IN} = 48V$ ,  $I_{OUT} = 6A$ ,  $T_a = 25degC$ ) with External Input Filter  
**Figure 19. Radiation Noise**



Unit under test (UUT) is covered by acrylic box to avoid airflow.  
( $V_{IN} = 48V$ , See [Technical Notes](#))  
**Figure 20. Thermal Derating**

MECHANICAL SPECIFICATIONS

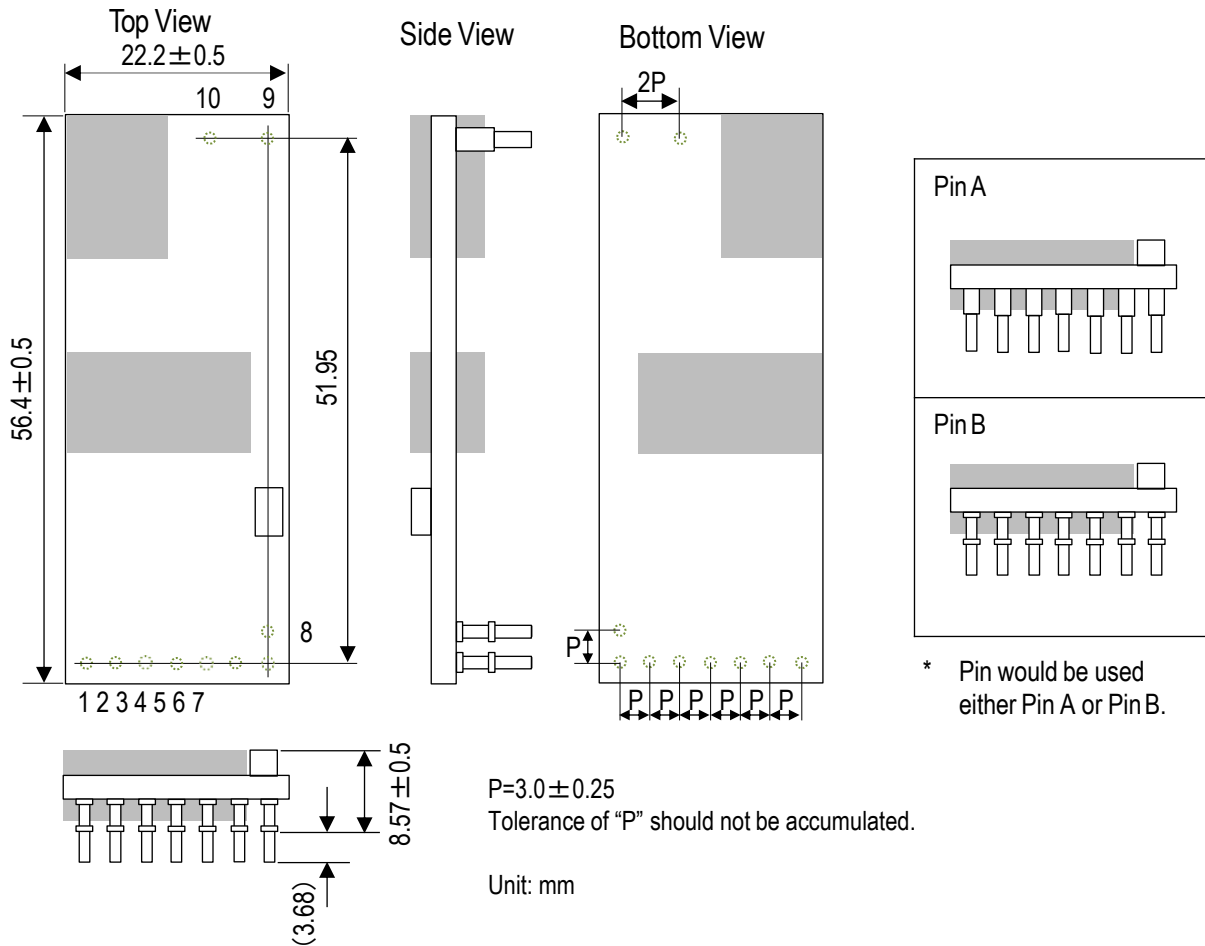


Figure 21. Product Dimensions

■ Pin Assignment

Table 4. Pin Function & Descriptions

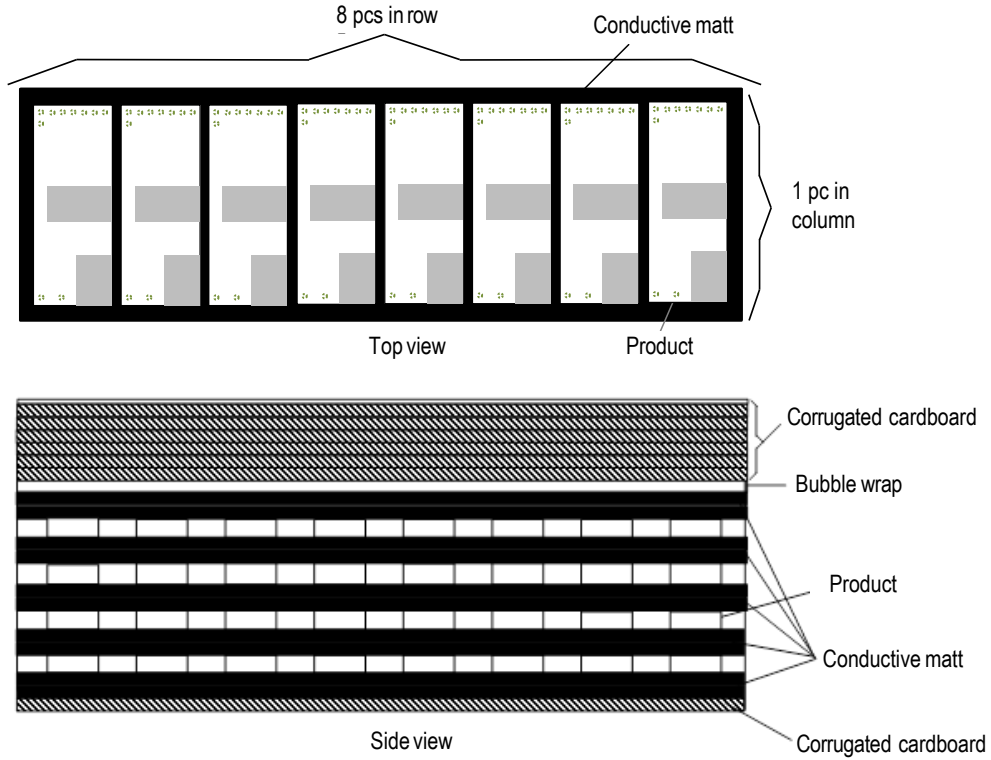
INPUT / OUTPUT CONNECTIONS				
Pin	Designation	Function	Pin size	Pin shoulder size
1	+Vin	Positive Input Voltage	Φ1.02	Φ1.57
2	RTN	External Input Capacitor	Φ1.02	Φ1.57
3	VC	Controller Voltage	Φ1.02	Φ1.57
4	BT	PSE Type Indicator	Φ1.02	Φ1.57
5	TPL	PSE Type Indicator	Φ1.02	Φ1.57
6	TPH	PSE Type Indicator	Φ1.02	Φ1.57
7	-Vin	Negative Input Voltage	Φ1.02	Φ1.57
8	DEN	Detection and Enable	Φ1.02	Φ1.57
9	-Vout	Negative Output Voltage	Φ1.57	Φ2.36
10	+Vout	Positive Output Voltage	Φ1.57	Φ2.36



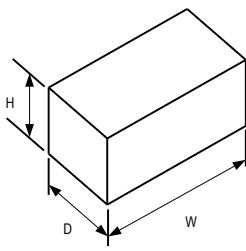
**PACKAGING INFORMATION**

Packaging form (Carton box)

1. The products are placed in the conductive mat (1 row × 8 columns) as below
2. Pile these conductive mats and pack maximum 4 units in carton box.

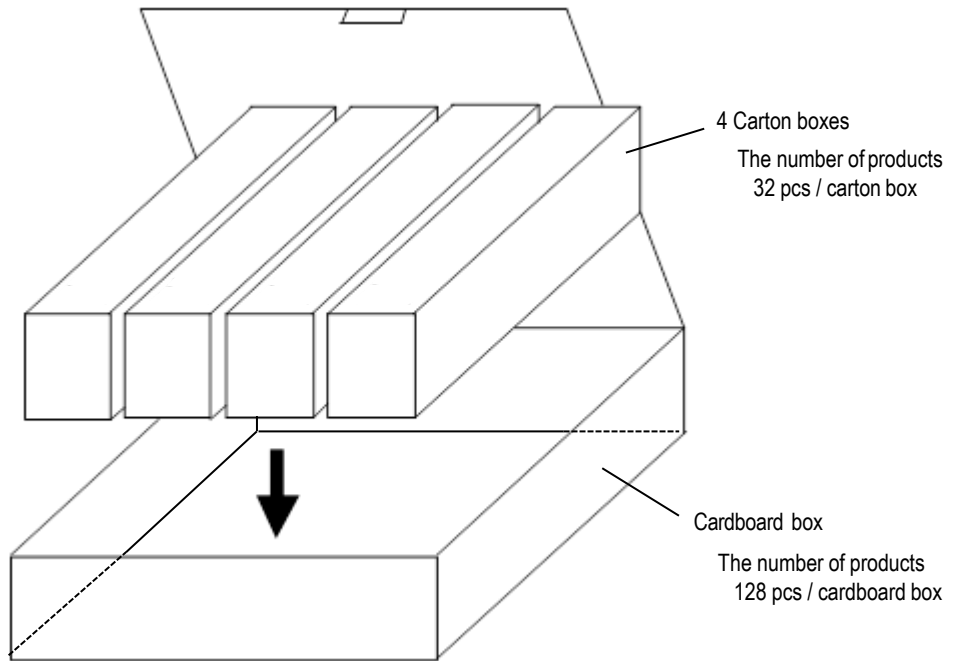


**Figure 23. Packaging Form (Carton box)**

Item	Specification	Remark • The number of contained products may not reach to the maximum number.
Packaging form typical classification	Box	
Dimensions of packaging form 	W = 245 ( mm ) D = 78 ( mm ) H = 104 ( mm )	
The number of products in a packaging form	32 ( pcs. )	

PACKAGING INFORMATION(CONT.)

Packaging form (Cardboard box)  
4 carton boxes per cardboard box.



**Figure 24. Packaging Form (Cardboard box)**

**TECHNICAL NOTES**

**Over Current Protection**

Over Current Protection operates with a controller circuit failure or over-load condition, and DC-DC converter will enter hiccup mode. After rejecting the abnormal mode, DC-DC converter will automatically restart.

**Over Voltage Protection**

Output halts in hiccup mode while Output Voltage is over the value of OVP specified with failure of controller circuit. DC-DC converter will enter a hiccup mode. After rejected the abnormal mode, DC-DC converter will automatically restart.

**Over Temperature Protection**

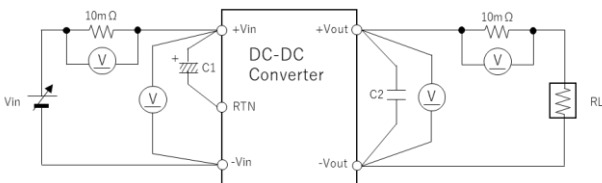
When DC-DC converter is heated abnormally, it will shut down. After it is cooled down, DC-DC converter will automatically restart.

**External Input Capacitor**

An external input capacitor can be added between positive input (+Vin) and RTN to stabilize the operation of the DC-DC converter. When EMI Suppression Filters are added, additional capacitors may be needed to stabilize the operation. The withstand voltage for the input voltage is required. But do not connect any capacitor between positive input(+Vin) and negative input(-Vin) to avoid large inrush current. It is one of the requirements of IEEE802.3bt standard.

**Test Circuit**

The initial values in Functional Specification are measured in the following test circuit.

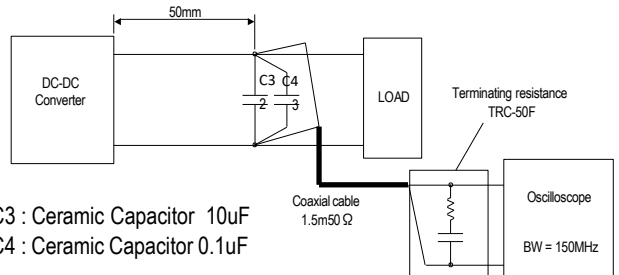


- C1 : Low Impedance Electrolytic Capacitor : None
- C2 : Ceramic Capacitor : 10uF+0.1uF
- RL : Electronic Load Device : LN-1000A-G7 KEISOKU GIKEN equivalent
- Vin : DC Power Supply :Model HP6675A KEYSIGHT equivalent
- (V) : Digital Multimeter :Model HP34401A KEYSIGHT equivalent

When deviating from the above, DC-DC converter may operate abnormally. It should be fully confirmed on your board before use.

**Ripple Noise Test**

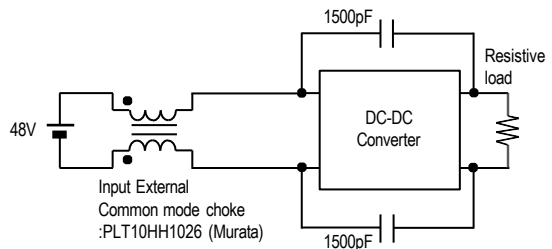
Output ripple noise is measured using designated external output components, circuits and layout as shown below.



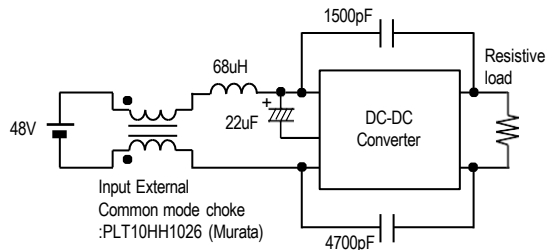
- C3 : Ceramic Capacitor 10uF
- C4 : Ceramic Capacitor 0.1uF

**EMI Test**

The external input filter is installed, and the circuit diagram is shown below.



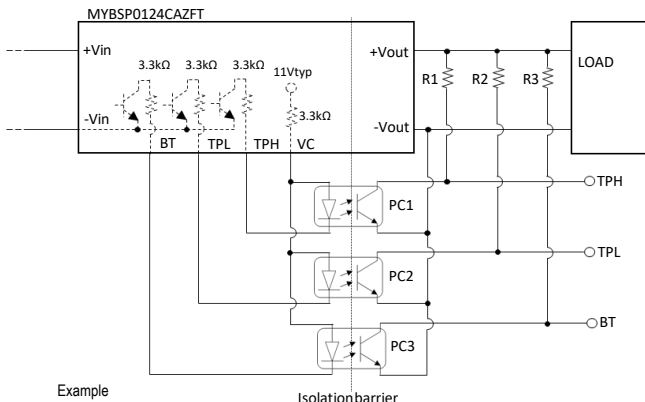
(A) MYBSP0124CAZFT



(B) MYBSP01206AZFT

### PSE Type Indicator

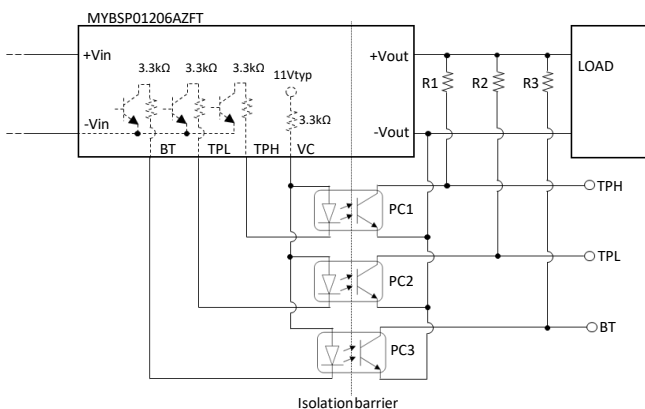
BT, TPL and TPH (Pin4~6) is open drain output. After classification with PSE Type 3-4, MYBSP0124CAZFT pulls BT and TPH Pins indicator low. After classification with PSE Type 4, MYBSP01206AZFT pulls 3 Pins indicator low. Please pull up BT, TPL and TPH by VC (Pin3). VC is the source only for this function. Do not apply VC for any other purpose. Appropriate board design for isolation barrier is required (Opto-coupler selection and Isolation distance). Also consider CTR of Opto-coupler which may affect value of R1~R3. Keep BT, TPL, TPH and VC open if you don't apply this function. Typical application circuit is below.



Example  
R1, R2, R3 : 15kΩ/0.1W  
PC1, PC2, PC3 : TLP293(GRH) (TOSHIBA)

PSE Type	PD Class	Number of CLASS Cycles	TPH	TPL	BT
1-2	0-3	1	HIGH	HIGH	HIGH
2	4	2	HIGH	LOW	HIGH
3-4	0-3	1	HIGH	HIGH	LOW
3-4	4	2-3	HIGH	LOW	LOW
3-4	5-6	4	LOW	HIGH	LOW

(A) MYBSP0124CAZFT



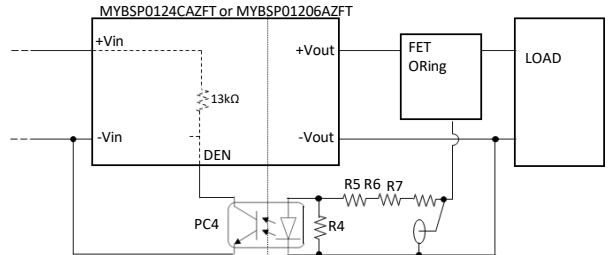
Example  
R1, R2, R3 : 15kΩ/0.1W  
PC1, PC2, PC3 : TLP293(GRH) (TOSHIBA)

PSE Type	PD Class	Number of CLASS Cycles	TPH	TPL	BT
1-2	0-3	1	HIGH	HIGH	HIGH
2	4	2	HIGH	LOW	HIGH
3-4	0-3	1	HIGH	HIGH	LOW
3-4	4	2-3	HIGH	LOW	LOW
3-4	5-6	4	LOW	HIGH	LOW
4	7-8	5	LOW	LOW	LOW

(B) MYBSP01206AZFT

### Adapter ORing

DEN (Pin8) handles Enable / Disable of MYBSP0124CAZFT and MYBSP01206AZFT. In case of applying external power output by adapter, MYBSP needs to be disable. Connecting DEN to -Vin disable MYBSP. There is limitation for voltage from adapter. Keep open if you don't use this function. Typical application circuit is below.



Example  
R4 : 3.3kΩ/0.1W  
R5, R6, R7 : 330Ω/0.25W  
PC4 : TLP293(GRH) (TOSHIBA)

### Limitation for adapter voltage

P/N	Acceptable voltage range from Adapter at V <sub>OUT</sub>
MYBSP0124CAZFT	10.8 to 12.8V
MYBSP01206AZFT	

### Thermal Derating Condition

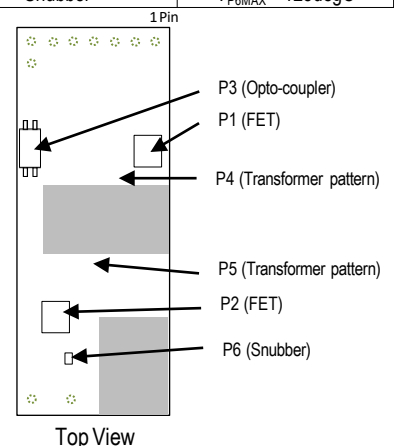
The output current is limited by the derating curve. The derating curve in this datasheet illustrate typical operation under a variety of conditions.

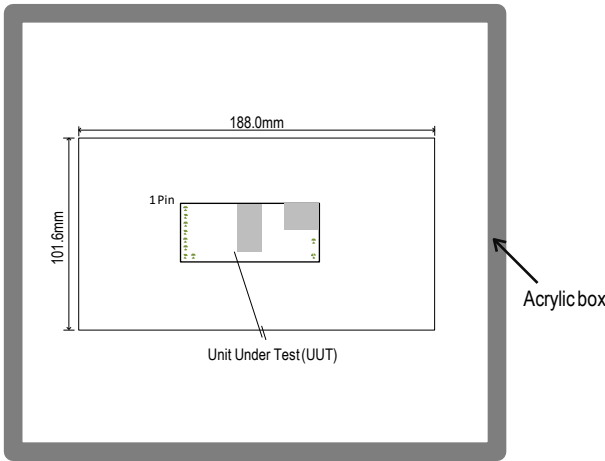
DC-DC Converter is tested on a 101.6x188mm, 2 layers Copper evaluation board at Vin=48V.

The Unit Under Test (UUT) is set up as shown below. UUT is covered by acrylic box to avoid airflow.

The temperature measurement points are shown below table. The temperature of measurement points should not exceed the maximum temperatures in the below table.

Position	Description	Max temperature
P1	FET	T <sub>P1MAX</sub> = 124degC
P2	FET	T <sub>P2MAX</sub> = 124degC
P3	Opto-coupler	T <sub>P3MAX</sub> = 105degC
P4	Transformer pattern	T <sub>P4MAX</sub> = 125degC
P5	Transformer pattern	T <sub>P5MAX</sub> = 125degC
P6	Snubber	T <sub>P6MAX</sub> = 125degC





**Through Hole Soldering Guidelines**

Murata recommends the specifications below when installing these converters. These specifications vary depending on the solder type. Exceeding these specifications may cause damage to the product. Your production environment may differ; therefore please thoroughly review these guidelines with your process engineers.

Flux : Rosin Flux which contains chlorine 0.2wt% or less.

Do not use high activity acid flux and water soluble flux.

Solder : Use the solder Sn-3Ag-0.5Cu or the equivalent type.

**Condition of Flow Soldering**

- Preheat : 120 ± 10 degC / 60 to 120seconds
- Soldering temperature : 260 degC +0/-5 degC
- Soldering time : 10 seconds max.

**Condition of Iron Soldering**

- Preheat : 120 ± 10 degC / 30 minutes max.
- Soldering temperature : 350 degC max.
- Soldering time : 3 seconds max.

**Detection and Hardware Classification**

DC-DC converter implements IEEE 802.3bt compliant detection and hardware classification.

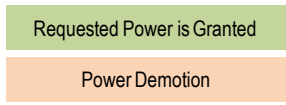
When DC-DC converter(PD) is connected to PSE, the PSE applies two voltages in the range of 2.7 to 10.1 V and measures the corresponding current. Connection to PD is detected by measured current.(Detection)

After Detection, the PSE applies voltage in the range of 14.5 to 20.5 V and measures the corresponding current. PD is classified by measured current.(Hardware Classification)

Please check with your application.

**Power Demotion**

Power Demotion allows the PSE to supply power to a PD even if the PSE does not have all of the PD's requested power available. Also it allows higher power PDs to operate in a reduced mode when connected to lower power PSEs.



Power Demotion						
Type Power	PSE Power Available	PD(25.5W) Class 4 Requested	PD(40W) Class 5 Requested	PD(51W) Class 6 Requested	PD(62W) Class 7 Requested	PD(71W) Class 8 Requested
Type1	15W	12.9W	12.9W	12.9W	12.9W	12.9W
Type2	30W	25.5W	25.5W	25.5W	25.5W	25.5W
Type 3	45W	25.5W	40W	25.5W	25.5W	25.5W
	60W	25.5W	40W	51W	51W	51W
Type4	75W	25.5W	40W	51W	62W	51W

### Scope

This datasheet is applied to MYBSP0124CAZFT and MYBSP01206AZFT.

- Specific applications: Consumer Electronics, Industrial Equipment

### Limitation of Applications

The products listed in the datasheet (hereinafter the product(s) is called the "Product(s)") are designed and manufactured for applications specified in the specification or the datasheet. (hereinafter called the "Specific Application"). We shall not warrant anything in connection with the Products including fitness, performance, adequateness, safety, or quality, in the case of applications listed in from (1) to (11) written at the end of this precautions, which may generally require high performance, function, quality, management of production or safety. Therefore, the Product shall be applied in compliance with the specific application.

We disclaim any loss and damages arising from or in connection with the products including but not limited to the case such loss and damages caused by the unexpected accident, in event that (i) the product is applied for the purpose which is not specified as the specific application for the product, and/or (ii) the product is applied for any following application purposes from (1) to (11) (except that such application purpose is unambiguously specified as specific application for the product in our catalog specification forms, datasheets, or other documents officially issued by us\*).

- (1) Aircraft equipment
- (2) Aerospace equipment
- (3) Undersea equipment
- (4) Power plant control equipment
- (5) Medical equipment
- (6) Transportation equipment (such as vehicles, trains, ships)
- (7) Traffic control equipment
- (8) Disaster prevention / crime prevention equipment
- (9) Industrial data-processing equipment
- (10) Combustion/explosion control equipment
- (11) Application of similar complexity and/or reliability requirements to the applications listed in the above

For exploring information of the Products which will be compatible with the particular purpose other than those specified in the datasheet, please contact our sales offices, distribution agents, or trading companies with which you make a deal, or via our web contact form.

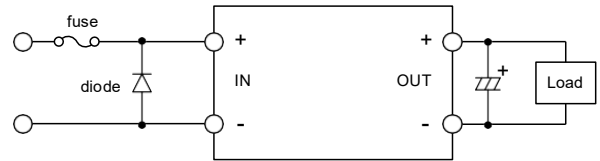
Contact form: <https://www.murata.com/contactform>

\*We may design and manufacture particular Products for applications listed in (1) to (11). Provided that, in such case we shall unambiguously specify such Specific Application in specification or datasheet without any exception. Therefore, any other documents and/or performances, whether exist or non-exist, shall not be deemed as the evidence to imply that we accept the applications listed in (1) to (11).

### Fail-safe function

Be sure to add an appropriate fail-safe function to your finished product to prevent secondary damage in the unlikely event of an abnormality function or malfunction in our product.

Please connect the input terminal by right polarity. If you mistake the connection, it may break the DC-DC converter. In the case of destruction of the DC-DC converter inside, over input current may flow. Please add a diode and fuse as follows to protect them.



Please select diode and fuse after confirming the operation.

### ⚠ Note

1. Please make sure that your product has been evaluated in view of your specifications with our product being mounted to your product.
2. You are requested not to use our product deviating from the reference specifications.
3. If you have any concerns about materials other than those listed in the RoHS directive, please contact us.
4. Please don't wash this product under any conditions.

### Storage

Please store the products in room where direct sunlight cannot come in and use the products within 6 months after delivery and maintain an appropriate storage condition using the following conditions.

- A temperature is +5 degC to +40 degC and a relative humidity is 20% to 70% as a standard condition. The temperature recommendation is less than 30 degC.
- If the storage period exceeds six months, check packaging, mounting, etc. before use.
- In addition, this may cause oxidation of the electrodes. If more than one year has elapsed since delivery, also check the solderability before use.
- Please do not store the products in the places such as: in a dusty place, in a place exposed directly to sea breeze, in an atmosphere containing corrosive gas (Cl<sub>2</sub>, NH<sub>3</sub>, SO<sub>2</sub>, NO<sub>x</sub> and so on).

#### Note Prior to use

If you apply high static electricity, voltage higher than rated voltage or reverse voltage to the product, it may cause defects in the products or degrade the reliability.

Please avoid the following items:

1. Over rating power supply, reverse power supply or not-enough connection of input voltage and 0V(DC)line
2. Electrostatic discharge by production line and/or operator
3. Electrified product by electrostatic induction

Do not subject product to excessive mechanical shock. If you drop the product on the floor it might cause a crack to the core of inductors and monolithic ceramic capacitors.

Also please pay attention to handling; the mounted parts can be dislodged if subjected to excessive force.

#### Operational environment and operational conditions

This product is not chemical-proof or rust-proof.

In order to prevent this product from leakage of electricity and/or abnormal temperature increase, do not use the product under the following circumstances:

- (1) in an atmosphere containing corrosive gas (Cl<sub>2</sub>, NH<sub>3</sub>, SO<sub>2</sub>, NO<sub>x</sub> and so on).
- (2) in a dusty place.
- (3) in a place exposed to direct sunlight.
- (4) in such a place where water splashes or in such a humid place where water condenses.
- (5) in a place exposed to sea breeze.
- (6) in any other places similar to the above (1) through (5).

Operational Conditions

Please use the product within specified values (power supply, temperature, input, output and load condition etc.). Input voltage drops due to line impedance, so please make sure that input voltage is within specified values.

If the product is used over the specified values, it may damage the product, reduce the quality, and even if the products can endure the condition for short time, it may cause degradation of the reliability.

#### Transportation

If you transport the product, please pack it so that the package will not be damaged by mechanical vibration or mechanical shock, and please educate and guide the carrier to prevent rough handling.

#### Product Specification

Product Specification in this datasheet are as of March 2026.

Specifications and features may change in any manner without notice.

Please check with our sales representatives or product engineers.

#### Contact form

<https://www.murata.com/contactform?Product=Power%20Device>

#### Patent Statement

Murata products are protected to under one or more of the U.S. patents.

#### Copyright and Trademark

©2026 Murata Manufacturing Co., Ltd. All rights reserved.

#### Disclaimers

The information described in this data sheet was carefully crafted for accuracy. However, this product is based on the assumption that it will be used after thoroughly verifying and confirming the characteristics and system compatibility. Therefore, Murata is not responsible for any damages caused by errors in the description of the datasheet.

Murata constantly strives to improve the quality and reliability of our products, but it is inevitable that semiconductor products will fail with a certain probability. Therefore, regardless of whether the use conditions are within the range of this data sheet, Murata is not responsible for any damage caused by the failure of this product., (for example, secondary damage, compensation for accidents, punitive damage, loss of opportunity, and etc.) Also, regardless of whether Murata can foresee the events caused by the failure of our product, Murata has no obligations or responsibilities.

The buyer of this product and developer of systems incorporating this product must analyze, evaluate, and make judgements at their own risk in designing applications using this product. The buyer and the developer are responsible for verifying the safety of this product and the applications, and complying with all applicable laws, regulations, and other requirements.

Furthermore, the buyer and developer are responsible for predicting hazards and taking adequate safeguards against potential events at your own risk in order to prevent personal accidents, fire accidents, or other social damage. When using this product, perform thorough evaluation and verification of the safety design designed at your own risk for this product and the application.

Murata assumes that the buyer and developer have the expertise to verify all necessary issues for proper use of the product as described above and to take corrective action. Therefore, Murata has no liability arising out of the use of the product. The buyer and developer should take all necessary evaluations, verifications, corrective actions and etc., in your own responsibility and judgment.

This data sheet does not guarantee or grant any license to the information, including patents, copyrights, and other intellectual property rights, of the Murata or third parties. Regardless of whether the information described in this datasheet is express or implied, Murata does not take any responsibility or liability for any claims, damages, costs, losses, etc. relating to intellectual property rights or other rights from third parties due to the use of these information.



This product is subject to the following [operating requirements](#) and the [Life and Safety Critical Application Sales Policy](#).

Refer to:

<https://www.murata.com/products/power/requirements>

Murata Manufacturing Co., Ltd makes no representation that the use of its products in the circuits described herein, or the use of other technical information contained herein, will not infringe upon existing or future patent rights. The descriptions contained herein do not imply the granting of licenses to make, use, or sell equipment constructed in accordance therewith. Spec and cautions are subject to change without notice.