

# DC-DC Converter DATA Sheet

## MYBEA01210CZT / MYBEA01210CZTB

### Feature:

1/8<sup>th</sup> Brick type Vin  
 18Vdc-36Vdc Vout  
 12Vdc  
 Iout 10Adc  
 120W

### Application:

This specification applies to DC-DC Converter MYBEA01210CZT/ MYBEA01210CZTB for telecommunication equipment.  
 Please contact us before using our products for the application except this application.

### 1. Appearance

MYBEA01210CZT



MYBEA01210CZTB



### 2. Part Number

Part Number	Base Plate Option
MYBEA01210CZT	No Base Plate
MYBEA01210CZTB	With Base Plate

### △Note:

- This datasheet is downloaded from the website of Murata Manufacturing co., ltd. Therefore, it's specifications are subject to change or our products in it may be discontinued without advance notice. Please check with our sales representatives or product engineers before ordering.
- This datasheet has only typical specifications because there is no space for detailed specifications. Therefore, please approve our product specifications or transact the approval sheet for product specifications before ordering.

3. Appearance, Dimensions

3.1. MYBEA01210CZT

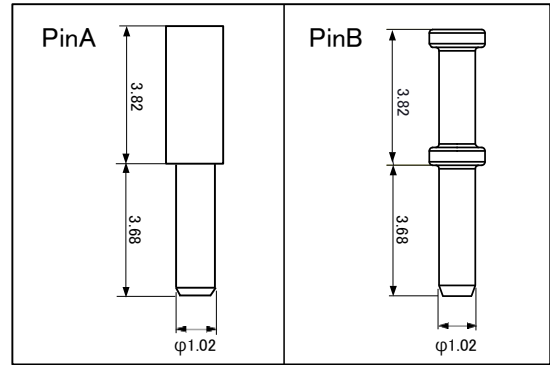
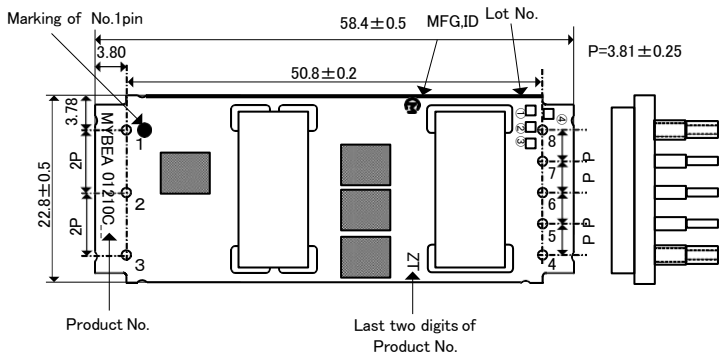

\*Pins 1, 2, 3, 5, 6 and 7 use either Pin A or Pin B.

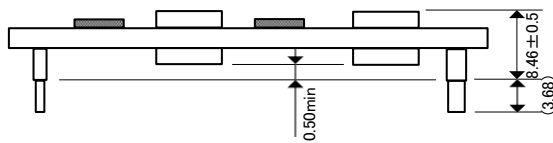

Pin No.	A: Stand-off portion	B: Insert portion to Via hole of PCB
1,2,3,5,6,7	φ1.57±0.15	φ1.02±0.15
4,8	φ2.36±0.15	φ1.57±0.15

Marking

- (1) Parts No. MYBEA01210CZT
- (2) MFG, ID
- (3) Lot No. □□□□

Terminal Specification  
Sn(100%)Plating on Ni over Copper Base

- ① Production Factory N: Wakura Murata Manufacturing Co., Ltd., T: Murata Electronics (Thailand), Ltd.
- ② Production Year
- ③ Production Month ( 1,2,3,...9, X, Y, Z )
- ④ Revision symbol Blank (no revision)

**△Note:**

- This datasheet is downloaded from the website of Murata Manufacturing co., ltd. Therefore, it's specifications are subject to change or our products in it may be discontinued without advance notice. Please check with our sales representatives or product engineers before ordering.
- This datasheet has only typical specifications because there is no space for detailed specifications. Therefore, please approve our product specifications or transact the approval sheet for product specifications before ordering.

3.2. MYBEA01210CZTB

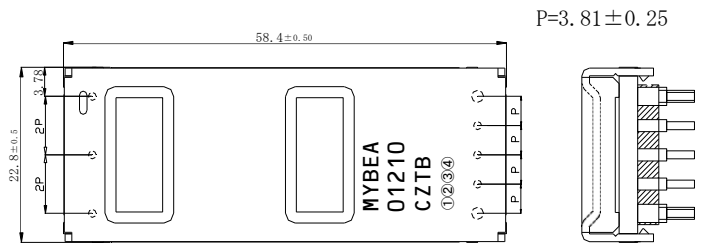
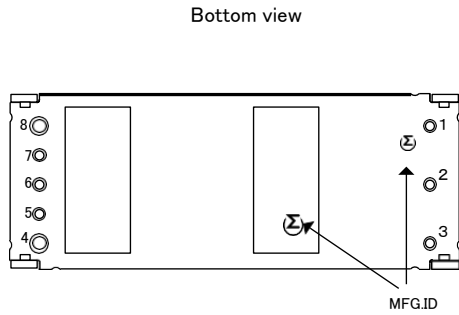

Pin No.	A: Stand-off portion	B: Insert portion to Via hole on PCB
1,2,3,5,6,7	$\phi 1.57 \pm 0.15$	$\phi 1.02 \pm 0.15$
4,8	$\phi 2.36 \pm 0.15$	$\phi 1.57 \pm 0.15$

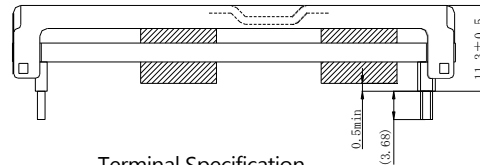

Terminal Specification  
Sn(100%), Ni over Copper Base

Marking

- (1) Parts No. MYBEA01210CZTB
- (2) MFG, ID
- (3) Lot No.

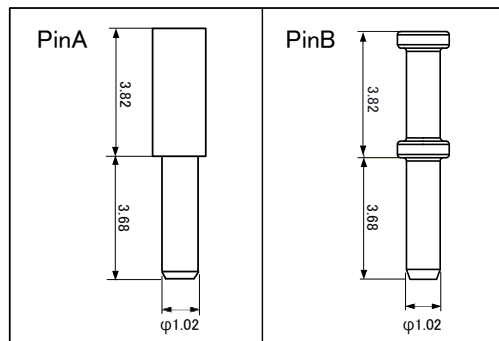

\*Pins 1, 2, 3, 5, 6 and 7 use either Pin A or Pin B.

- ① Factory N: Wakura Murata Manufacturing Co., Ltd., T: Murata Electronics (Thailand), Ltd.
- ② Production Year Last number of year
- ③ Production Month (1,2,3,...9,X,Y,Z)
- ④ Revision symbol Blank (no revision)

P in Number, Function

Pin No.	Signal	Function
1	Vin(+)	Positive Input Voltage
2	ON/OFF	Remote ON/OFF
3	Vin(-)	Negative Input Voltage
4	Vout(-)	Negative output Voltage
5	SENSE(-)	Negative Remote Sense
6	TRIM	Output Voltage Adjustment
7	SENSE(+)	Positive Remote Sense
8	Vout(+)	Positive output Voltage

**△Note:**

- This datasheet is downloaded from the website of Murata Manufacturing co., ltd. Therefore, it's specifications are subject to change or our products in it may be discontinued without advance notice. Please check with our sales representatives or product engineers before ordering.
- This datasheet has only typical specifications because there is no space for detailed specifications. Therefore, please approve our product specifications or transact the approval sheet for product specifications before ordering.

## 4. Absolute Maximum Ratings

Item		Unit	Absolute Rating	Remarks
Minimum Input Voltage		V	0	
Maximum Input Voltage	Time			
	Continuous	V	36	
	100ms	V	50	Slew rate 26V/10 $\mu$ s
ON/OFF pin Control Voltage	Maximum	V	7	
	Minimum	V	0	

## 5. Rating

1. Operating Temperature Range    -40°C ~ +85°C ( Caution: Please refer the temperature derating. )
2. Operating Humidity Range        20% ~ 85% ( with no dew deposit )
3. Storage Temperature Range       -45°C ~ +90°C
4. Storage Humidity Range          10% ~ 95% ( with no dew deposit )
5. Maximum Wet Bulb temperature   39°C

**△Note:**

1. This datasheet is downloaded from the website of Murata Manufacturing co., Ltd. Therefore, it's specifications are subject to change or our products in it may be discontinued without advance notice. Please check with our sales representatives or product engineers before ordering.
2. This datasheet has only typical specifications because there is no space for detailed specifications. Therefore, please approve our product specifications or transact the approval sheet for product specifications before ordering.

## 6. Electrical Characteristics

## 6.1. General Characteristics

Item	Symbol	Condition	Value			Unit
			Min.	Typ.	Max.	
Input Voltage Range	Vin		18	24	36	V
Turn-on Input Voltage		Vin=increasing	15	-	18	V
Input Voltage difference of Turn-on and Turn-off			2.0	-	-	V
Galvanic Isolation Voltage		Voltage applied for 1 minute Cutoff Current:1mA Ta=25°C±10°C 60%±15RH	1500	-	-	Vdc
Galvanic Isolation Voltage ( Input-Base Plate /Output-Base Plate )		Voltage applied for 1 minute Cutoff Current:1mA Ta=25°C±10°C 60%±15RH	750			Vdc

## 6.2. EMI,Safety Standard

Item	Standard	Note
Noise (Radiation, Conduction)	In accordance with VCCI Class A	Refer to Test Circuit in clause 10
Safety Standard	Recognized UL60950(UL/C-UL), Complied IEC 60950	UL file No.E190503
	CE Marking	CE Mark is shown on a package box.

## 6.3. Protection Cuircuit

Item	Value
Protection	If output is shorted , or output voltage is over the value specified in OVP , or DC-DC converter is heated abnormally, DC-DC converter will enter a hiccup mode where it repeatedly turn on and off. After rejected the abnormal mode, DC-DC converter will automatically restart. However output short, output over voltage, and abnormal heating affect long-term reliability.

**△Note:**

1. This datasheet is downloaded from the website of Murata Manufacturing co., ltd. Therefore, it' s specifications are subject to change or our products in it may be discontinued without advance notice. Please check with our sales representatives or product engineers before ordering.
2. This datasheet has only typical specifications because there is no space for detailed specifications. Therefore, please approve our product specifications or transact the approval sheet for product specifications before ordering.

## 6.4. Specific Characteristics (Ta= -40 to +85°C with temperature derated.)

Test circuit is mentioned in section 7.

Item	Symbol	Z	Value			Unit
			Min.	Typ.	Max.	
Output Voltage	Vout	Vin =Min ~ Max Iout=Min ~ Max	11.64	12	12.36	V
Output Voltage Adjustable Range	Vout(adj)		-20	-	+10	%
Output Current	Iout		0	-	10.0	A
Ripple Noise Voltage	Vripl		-	-	200	mV(p_p)
Efficiency	$\eta$	Vin=24V Iout=10A Ta=25°C	-	93	-	%
ON/OFF pin Control Voltage	Von		0	-	0.7	V
	Voff		2	-	-	V
RC start up delay time	trc	Vin =Min ~ Max Iout=Min ~ Max RC connected with -Vin to Vout×90%	-	5	-	ms
Setting point of Over Current Protection	OCP	Vin =Min ~ Max	10.3	-	-	A
Setting point of Over Voltage Protection	OVP	Vin =Min ~ Max	14.4	-	-	V
External Output Capacitance	Cout	Ceramic capacitor	100	-	2000	$\mu$ F

## 6.5. Weight

Item	Product Name	Value			Unit
		Min	Typ.	Max.	
Weight	MYBEA01210CZT	-	21.4		g
	MYBEA01210CZTB	-	29.7		

**△Note:**

1. This datasheet is downloaded from the website of Murata Manufacturing co., Ltd. Therefore, it's specifications are subject to change or our products in it may be discontinued without advance notice. Please check with our sales representatives or product engineers before ordering.
2. This datasheet has only typical specifications because there is no space for detailed specifications. Therefore, please approve our product specifications or transact the approval sheet for product specifications before ordering.

## 6.6. To Adjust Output Voltage

When TRIM-pin (6pin) is left open, DC-DC converter applies nominal output voltage.

Resistors connected between TRIM-pin(6pin) to SENSE(+)-pin (7pin) will increase the output voltage (Vo,adj) between 100% ~ 110% of the nominal output voltage(Vo,nom). (Vout-Up control)

Resistors connected between TRIM-pin(6pin) to SENSE(-)-pin (5pin) will decrease the output voltage(Vo,adj) between 80% ~ 100% of the nominal output voltage(Vo,nom). (Vout-Down control)

The following equations give the required external-resistor value to adjust the output voltage to Vo,adj. After calculating external resistance, it is necessary to check the output voltage and to adjust of the resistance value at your board conditions.

1) When you increase the output voltage,

$$R_{adj-up} = \left[ \frac{5.1 \times V_o(100\% + \Delta(\%))}{1.225 \times \Delta(\%)} - \frac{5.1 \times 100(\%)}{\Delta(\%)} - 10.22 \right] [\text{k}\Omega]$$

where,

$$\Delta = \left| \frac{V_o, adj - V_o, nom}{V_o, nom} \right| \times 100(\%)$$

when you decrease the output voltage,

$$R_{adj-down} = \left[ \frac{5.1 \times 100(\%)}{\Delta(\%)} - 10.22 \right] [\text{k}\Omega]$$

where,

$$\Delta = \left| \frac{V_o, nom - V_o, adj}{V_o, nom} \right| \times 100(\%)$$

If you change output voltage, it is necessary to evaluate the characteristics of DC-DC converter at your board conditions.

### △Note:

1. This datasheet is downloaded from the website of Murata Manufacturing co., ltd. Therefore, it's specifications are subject to change or our products in it may be discontinued without advance notice. Please check with our sales representatives or product engineers before ordering.
2. This datasheet has only typical specifications because there is no space for detailed specifications. Therefore, please approve our product specifications or transact the approval sheet for product specifications before ordering.

### 6.7. ON/OFF control

#### 1) On control

ON/OFF Pin (2Pin) should be connected to Vin(-) Pin (3Pin), or keeps less than 0.7V.

#### 2) Off control

ON/OFF Pin (2Pin) should be opened, or the current from ON/OFF Pin (2Pin) to Vin(-) Pin (3Pin) is controlled less than 30uA.

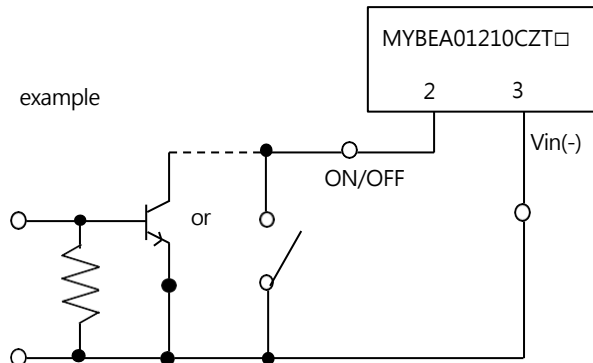

The voltage of maximum 5V appears in the ON/OFF pin at the time of pin opening.

### 6.8. External input capacitor

When an inductance or a switch device is connected to Input line, or when the transient response of input power supply is bad, input voltage is greatly changed at the time of load sudden change of DC-DC converter.

Since the load response of DC-DC converter may not be normally demonstrated by this influence, and DC-DC converter may cause unusual oscillation, in such a case, please connect an external input capacitor.

### 6.9. Output voltage remote sense

It has the remote sense function which corrects a voltage drop by the line drop from the power supply output terminal to the load terminal.

A voltage drop by the line drop can be corrected by connecting No.5 pin and No.7 pin to the load terminal part.

At the time of a remote sense, a remote sense line is to use a shielding wire, a twist line, a side by side pattern, and so on, and reduce the influence of the noise.

A Output Voltage Remote Sense Range is  $V_{out}(\text{nom})$  within +5%. And, use an output voltage within the output adjustment range.

Short-circuit No.4 -No.5 terminal and No.7- No.8 terminal respectively when a remote sense shouldn't be necessary.

If you use an output voltage remote sense, it is necessary to evaluate the characteristics of DC-DC converter at your board conditions.

#### △Note:

1. This datasheet is downloaded from the website of Murata Manufacturing Co., Ltd. Therefore, its specifications are subject to change or our products in it may be discontinued without advance notice. Please check with our sales representatives or product engineers before ordering.
2. This datasheet has only typical specifications because there is no space for detailed specifications. Therefore, please approve our product specifications or transact the approval sheet for product specifications before ordering.

## 7. Test Circuit

In the following test circuit, the initial values in item 6 should be met.

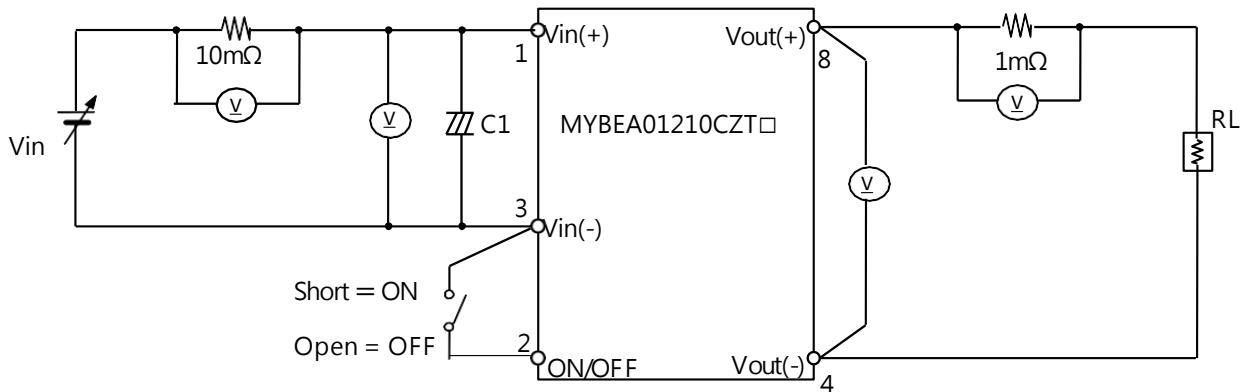

C1 :	Low Impedance Electrolytic Capacitor 100 $\mu$ f
RL :	Electronic Load Device :Model ELL355 KEISOKUGIKEN equivalent
Vin :	DC Power Supply :Model HP6675A HP equivalent
 :	Digital Multimeter :Model HP34401A HP equivalent

※When deviating from the above, DC-DC converter may operate abnormally. It should be fully confirmed on your board before use.

## ※ Ripple Noise Test

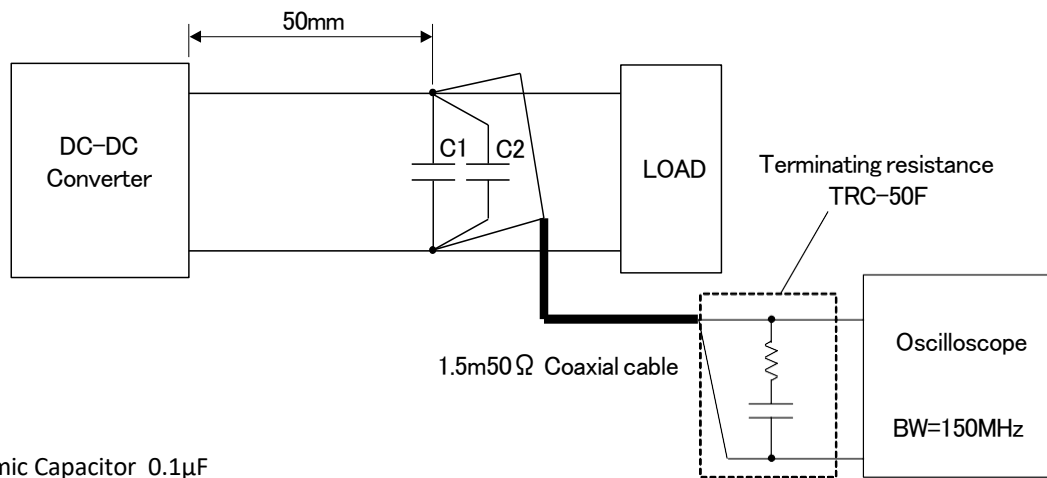

C1 :	Ceramic Capacitor 0.1 $\mu$ F
C2 :	Ceramic Capacitor 10 $\mu$ F

**△Note:**

1. This datasheet is downloaded from the website of Murata Manufacturing co., ltd. Therefore, it's specifications are subject to change or our products in it may be discontinued without advance notice. Please check with our sales representatives or product engineers before ordering.
2. This datasheet has only typical specifications because there is no space for detailed specifications. Therefore, please approve our product specifications or transact the approval sheet for product specifications before ordering.

### ※ Radiation Noise

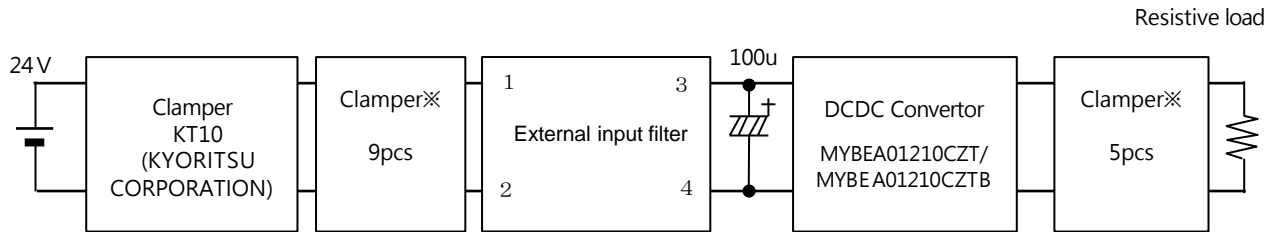

※Clamper : ZCAT3035-1330(TDK)

### ※Conduction Noise

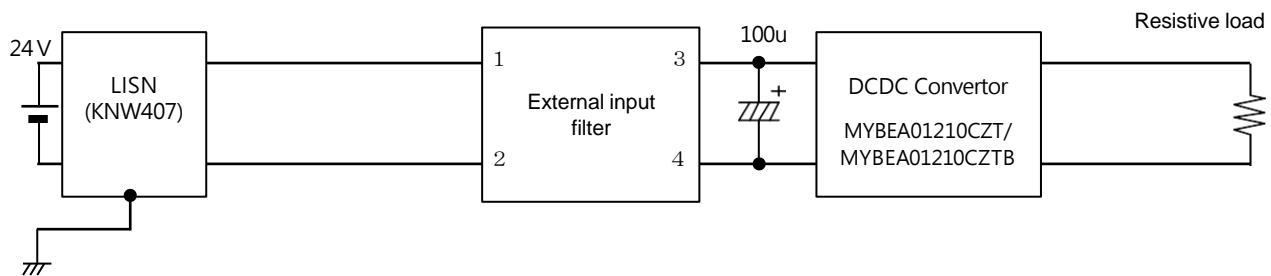

#### External input filter

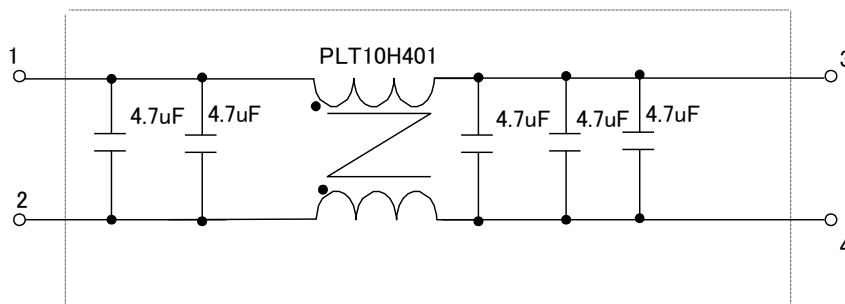

Measurement at Radiation Noise, Conductive Noise, Output ripple & Noise.

Please measure Radiation Noise, Conductive Noise and Output ripple & Noise with conforming to the Test Circuit in section 7

Otherwise the noise might not meet the specified values.

#### △Note:

1. This datasheet is downloaded from the website of Murata Manufacturing co., ltd. Therefore, it's specifications are subject to change or our products in it may be discontinued without advance notice. Please check with our sales representatives or product engineers before ordering.
2. This datasheet has only typical specifications because there is no space for detailed specifications. Therefore, please approve our product specifications or transact the approval sheet for product specifications before ordering.

## 8. Mechanical Tests

### 8.1. Vibration

Vibration frequency : 10 ~ 55Hz  
 Amplitude : 1.5mm max  
 10 to 55Hz · 1.5mm amplitude, 1 hour for each of X,Y,Z directions.  
 No damage in appearance and no deviation from electrical characteristics.

### 8.2. Mechanical Shock

20G, 1 time for each X,Y,Z directions.  
 No damage in appearance and no deviation from electrical characteristics.

### 8.3. Soldering Heat Resistance

Touch a solder iron to the pin of DC-DC Converter for 3±0.5 seconds.  
 Solder iron : MAX 30W , 350°C  
 There should be no damage in appearance.  
 Measure the DC-DC Converter after 2 hours and the initial values in item 7 should be met.

### 8.4. Pull Strength

Fasten the body of DC-DC Converter and pull the lead gradually in a radial direction with 5.0N load, keep the load for 5 seconds. The body should not be damaged thereafter.

## 9. Environmental Tests

### 1) Humidity Test

Subjected to a temperature 40°C±2°C with 90 ~ 95% for 100 hours.  
 Return to room temperature (25°C) for 2 hours and measure. The initial values in item 7 should be met. (JIS-C-0022)

### 2) Thermal Cycle Test

Subjected to 5 cycle of the following.  
 Placed in room temperature (25°C) for 2 hours and are measured.  
 The initial values in item 6 should be met.

Step	Condition	Time
1	-40°C±3°C	30 minutes
2	Room Temp.	5 ~ 10 minutes
3	+85°C±3°C	30 minutes
4	Room Temp.	5 ~ 10 minutes

### 9.1. MTBF Reliability Prediction (For reference only)

MTBF is 2.04million hours = 233 years  
 at 50% nominal output current , Ambient Temperature Ta=40°C, calculated by Telcordia SR-332.

#### △Note:

1. This datasheet is downloaded from the website of Murata Manufacturing co., ltd. Therefore, it's specifications are subject to change or our products in it may be discontinued without advance notice. Please check with our sales representatives or product engineers before ordering.
2. This datasheet has only typical specifications because there is no space for detailed specifications. Therefore, please approve our product specifications or transact the approval sheet for product specifications before ordering.

10. Packaging Information

10.1. MYBEA01210CZT

10.1.1. Tray Dimensions

DC-DC converters are packaged in the conductive trays. (See Fig.1)  
 Each tray is covered by tray cover.(See Fig.2)

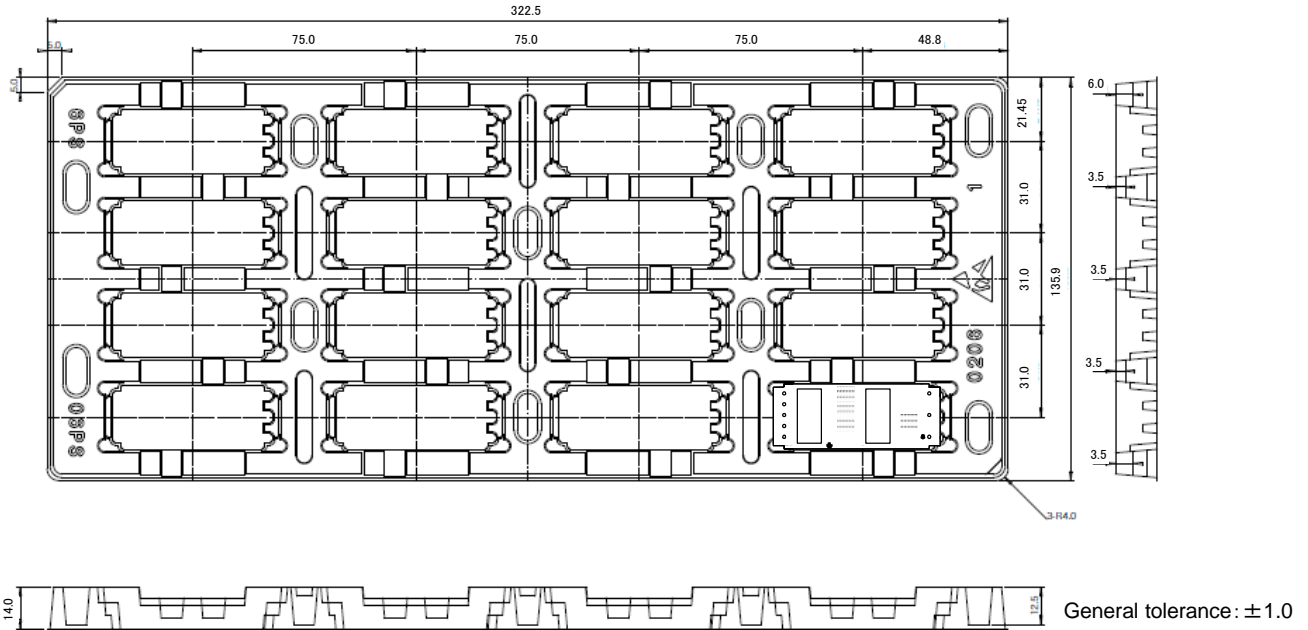

Fig.1

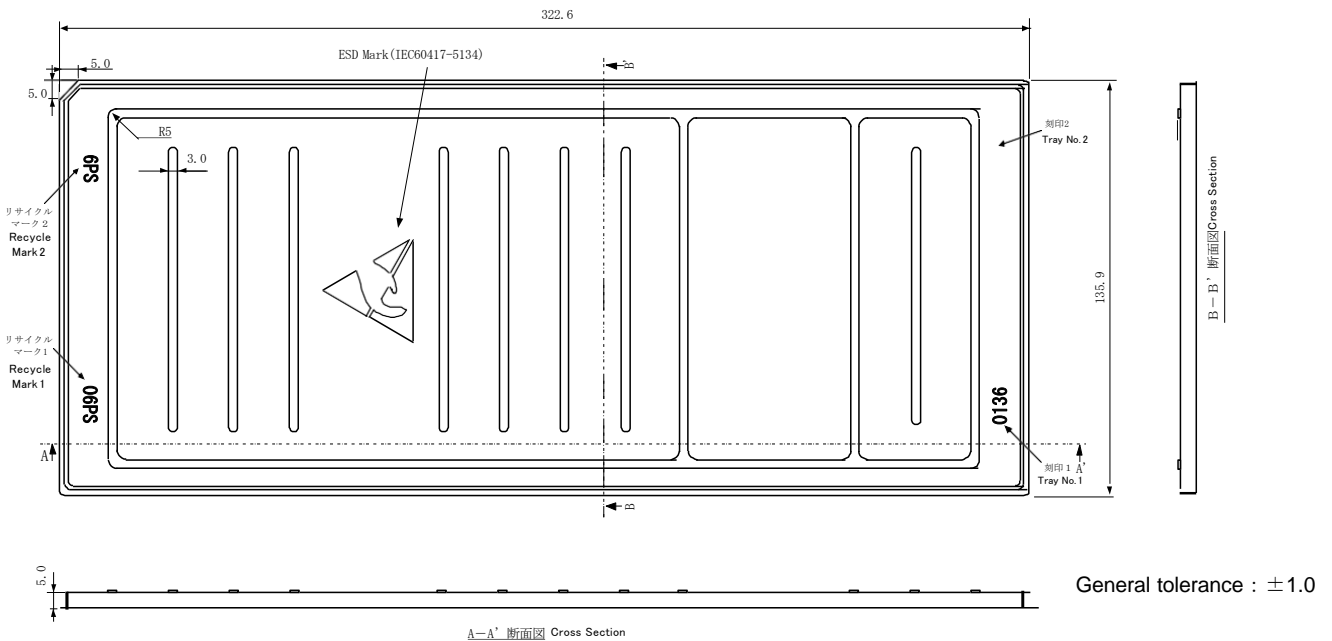

Fig.2

△Note:

1. This datasheet is downloaded from the website of Murata Manufacturing co., ltd. Therefore, it's specifications are subject to change or our products in it may be discontinued without advance notice. Please check with our sales representatives or product engineers before ordering.
2. This datasheet has only typical specifications because there is no space for detailed specifications. Therefore, please approve our product specifications or transact the approval sheet for product specifications before ordering.

### 10.1.2. Pieces of contained products per corrugated box.

Maximum contained products pieces 64 pcs/corrugated box.

Further plural sheets of corrugated cardboard are placed on the top of the tray cover according to number of contained trays in order to full up the space in a corrugated box.

### 10.1.3. Packaging Form

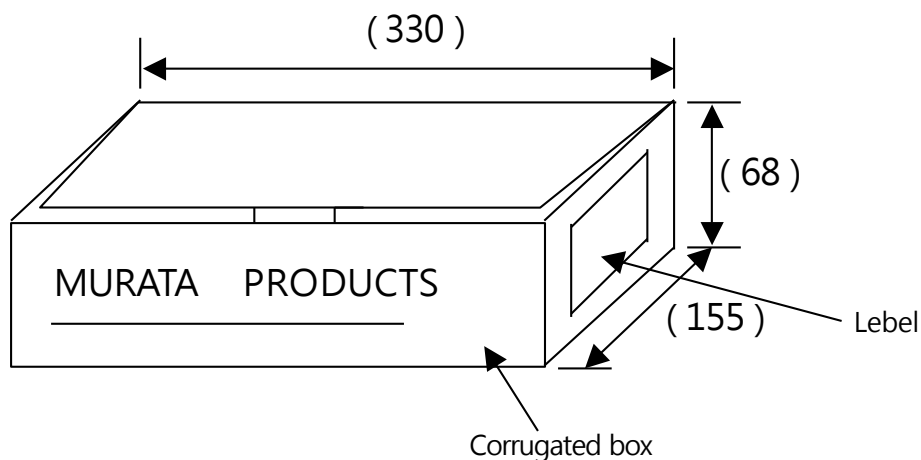
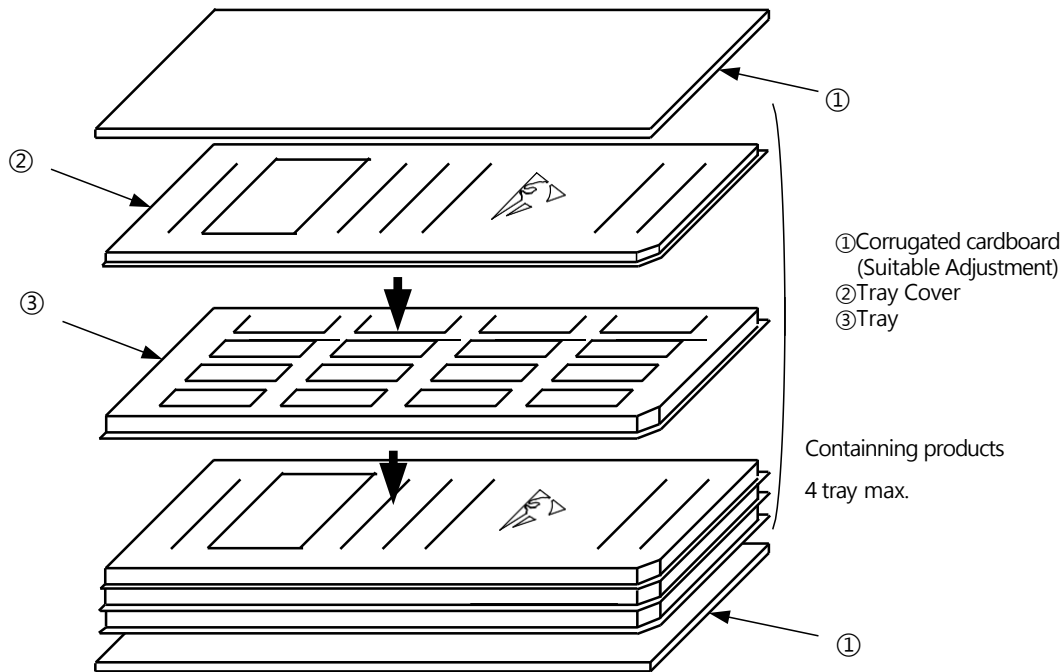

Dimension [unit : mm]of corrugated box is reference only.

Fig.3

- ※ Marking on the box
- MURATA Parts Number
  - Quantity
  - Inspection No.
  - RoHS - Y

#### △Note:

1. This datasheet is downloaded from the website of Murata Manufacturing co., ltd. Therefore, it's specifications are subject to change or our products in it may be discontinued without advance notice. Please check with our sales representatives or product engineers before ordering.
2. This datasheet has only typical specifications because there is no space for detailed specifications. Therefore, please approve our product specifications or transact the approval sheet for product specifications before ordering.

## 10.2. MYBEA01210CZTB

## 10.2.1. Packaging form

- ① Like the below figure, put the products on a conductive mat. (1row×8column) (See Fig.4)
- ② Pile these conductive mats and pack maximum 4 units. (See Fig.5)

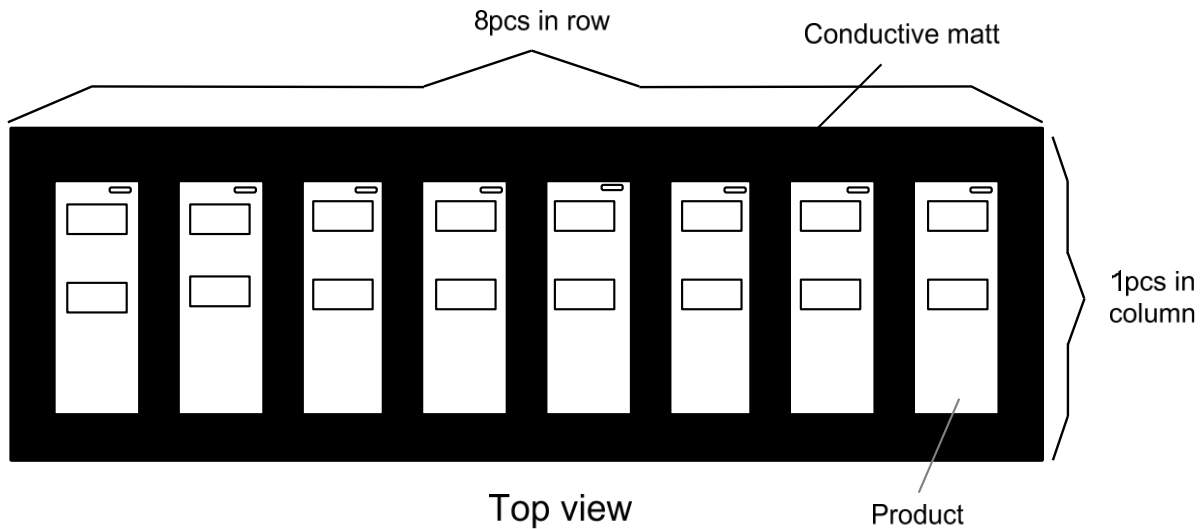

Fig.4

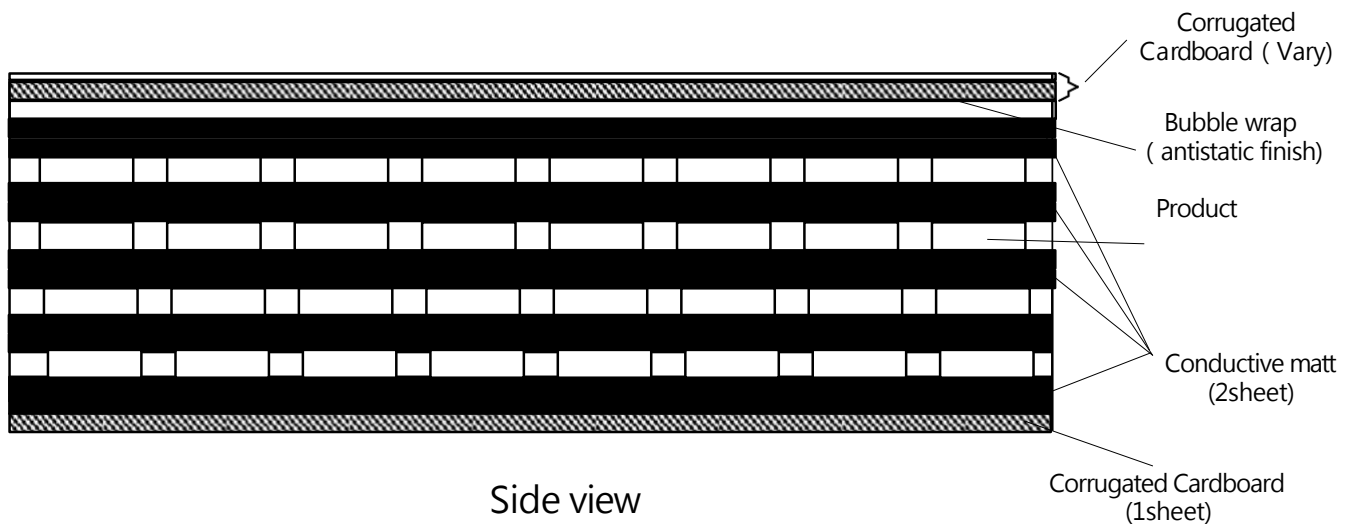
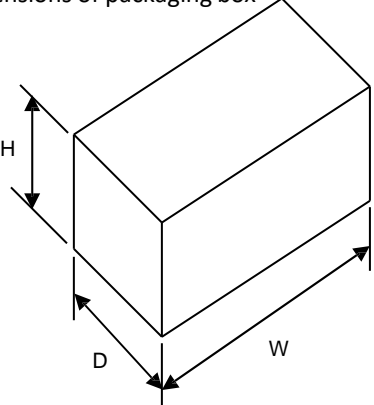

Fig.5

**△Note:**

1. This datasheet is downloaded from the website of Murata Manufacturing co., ltd. Therefore, it's specifications are subject to change or our products in it may be discontinued without advance notice. Please check with our sales representatives or product engineers before ordering.
2. This datasheet has only typical specifications because there is no space for detailed specifications. Therefore, please approve our product specifications or transact the approval sheet for product specifications before ordering.

Item	Specification
Packaging form typical classification	Box
<p>Dimensions of packaging box</p> 	<p>W = 245 ( mm ) D = 78 ( mm ) H = 104 ( mm )</p>
Maximum number in a box	32(pcs)
<p>Remark</p> <p>The number of contained products may not reach to the maximum number.</p> <p>Marking on the box</p> <ol style="list-style-type: none"> <li>1. MURATA Parts Number</li> <li>2. Quantity</li> <li>3. Inspection No.</li> <li>4. CE Mark</li> <li>5. ROHS—Y</li> </ol>	

**△Note:**

1. This datasheet is downloaded from the website of Murata Manufacturing co., ltd. Therefore, it's specifications are subject to change or our products in it may be discontinued without advance notice. Please check with our sales representatives or product engineers before ordering.
2. This datasheet has only typical specifications because there is no space for detailed specifications. Therefore, please approve our product specifications or transact the approval sheet for product specifications before ordering.

## 11. Reference data

## 11.1. Temperature Derating &lt;For Reference Only&gt;

## 11.1.1. No Base Plate

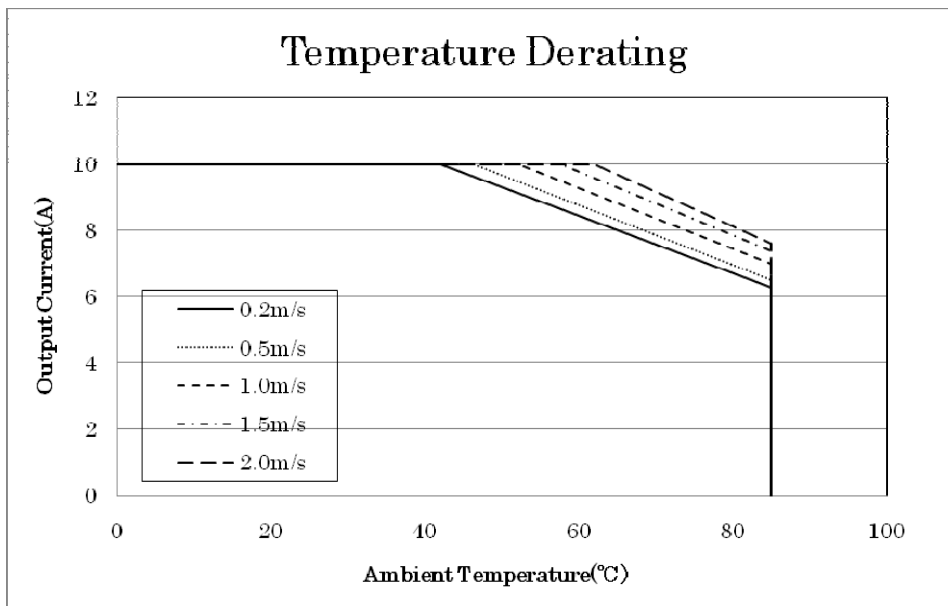

MYBEA01210AZT is tested on the evaluation board (size 237x237, 12 layers Copper), and the output voltage setting is 12V(Trim pin is Open).

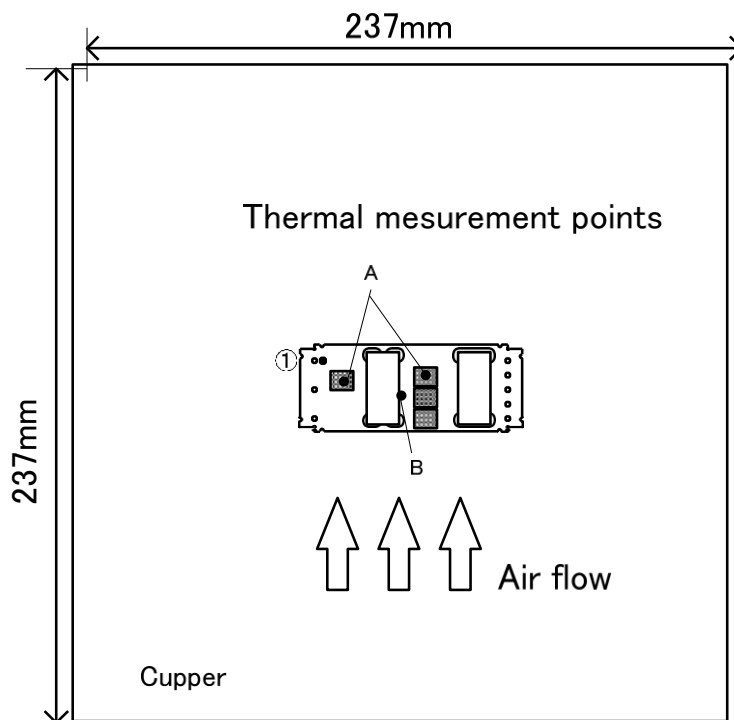

Cool the thermal measure points less than 119deg show in the next page.

**△Note:**

1. This datasheet is downloaded from the website of Murata Manufacturing co., ltd. Therefore, it's specifications are subject to change or our products in it may be discontinued without advance notice. Please check with our sales representatives or product engineers before ordering.
2. This datasheet has only typical specifications because there is no space for detailed specifications. Therefore, please approve our product specifications or transact the approval sheet for product specifications before ordering.

## 11.1.2. With Base Plate

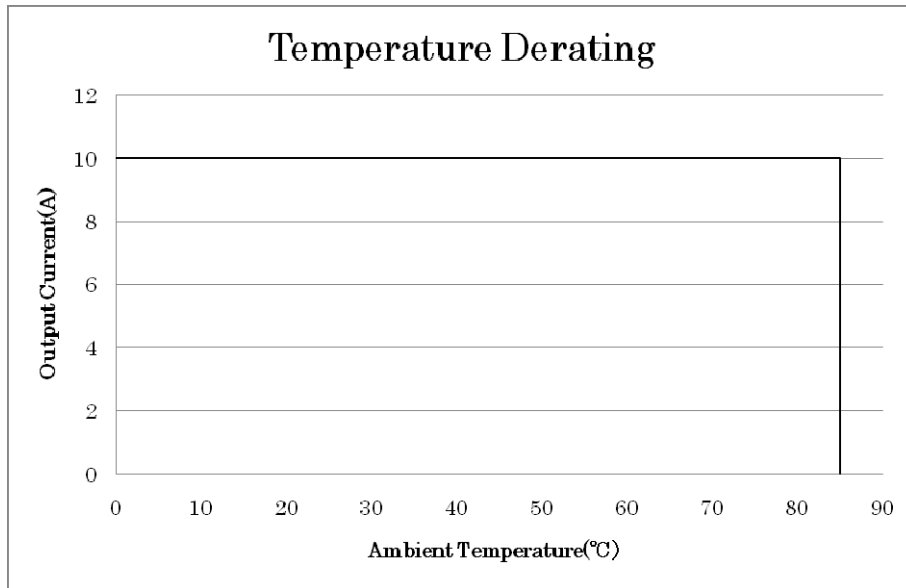

MYBEA01210CZTB is tested on the evaluation board (size 101.6x180, 2 layers ) and keep Base Plate surface Temperature under 100degC.

The output voltage setting is 12V(Trim pin is Open).

Cool the thermal measure points A and B less than 100deg show in the below drawing.

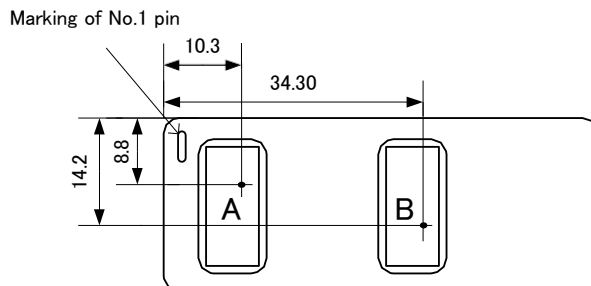
**△Note:**

1. This datasheet is downloaded from the website of Murata Manufacturing co., ltd. Therefore, it's specifications are subject to change or our products in it may be discontinued without advance notice. Please check with our sales representatives or product engineers before ordering.
2. This datasheet has only typical specifications because there is no space for detailed specifications. Therefore, please approve our product specifications or transact the approval sheet for product specifications before ordering.

## 12. Electrical data(Reference only)

## 12.1. Efficiency

Ta=25°C

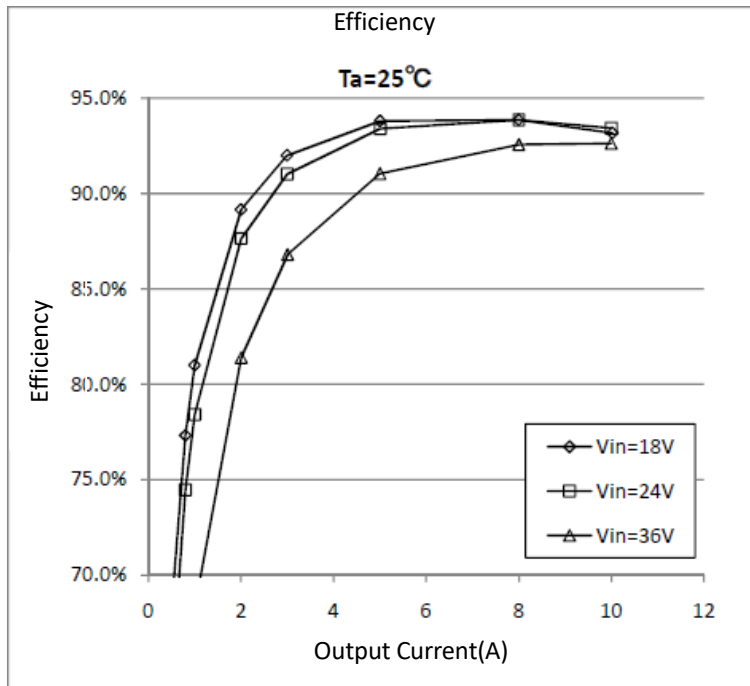

## 12.2. Output Ripple noise

Vin=24Vdc Full Load Ta=25°C

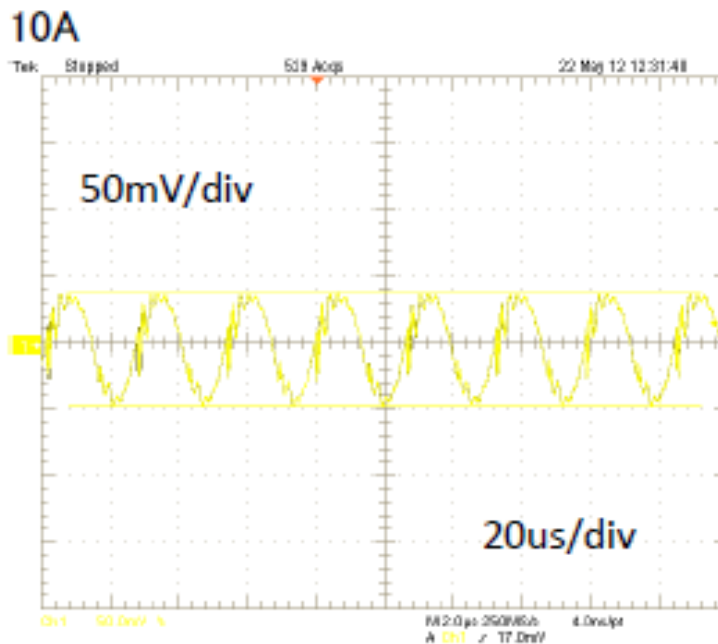

## △Note:

1. This datasheet is downloaded from the website of Murata Manufacturing co., Ltd. Therefore, it's specifications are subject to change or our products in it may be discontinued without advance notice. Please check with our sales representatives or product engineers before ordering.
2. This datasheet has only typical specifications because there is no space for detailed specifications. Therefore, please approve our product specifications or transact the approval sheet for product specifications before ordering.

## 12.3. Remote Control Start

Vin=24Vdc Full Load Ta=25°C

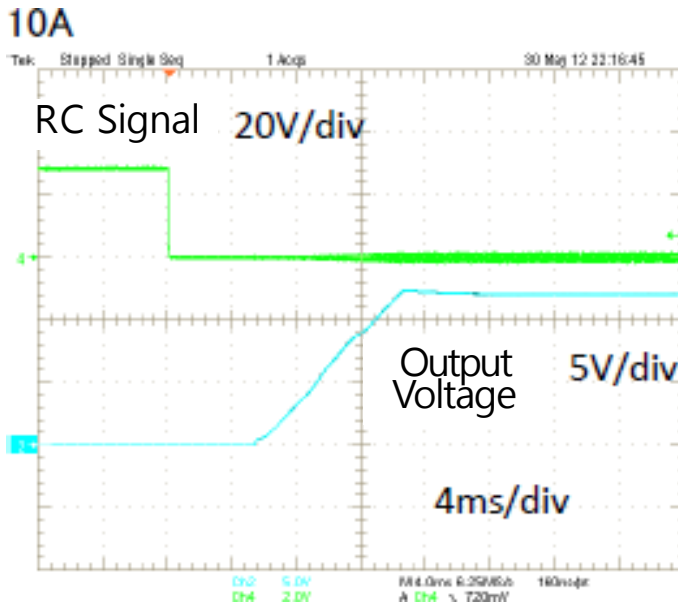

## 12.4. Remote Control Stop

Vin=24Vdc Full Load Ta=25°C

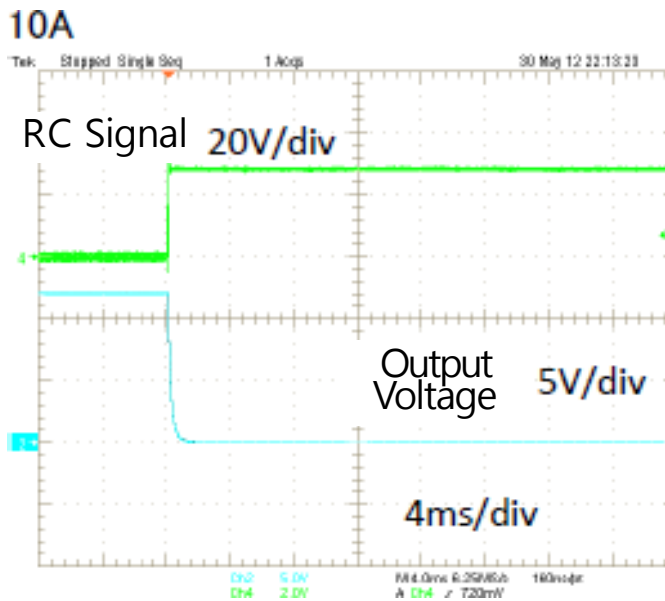
**△Note:**

1. This datasheet is downloaded from the website of Murata Manufacturing co., Ltd. Therefore, it's specifications are subject to change or our products in it may be discontinued without advance notice. Please check with our sales representatives or product engineers before ordering.
2. This datasheet has only typical specifications because there is no space for detailed specifications. Therefore, please approve our product specifications or transact the approval sheet for product specifications before ordering.

## 13. Notice

## 13.1. Soldering

## 13.1.1. Flux

Please solder the product with Rosin Flux, which contains chlorine 0.2wt% or less.

Please do NOT use acid flux or water-soluble flux, which could corrode metals and glass of the product.

## 13.1.2. Solder

Lead Free Solder

Please use solder Sn-3Ag-0.5Cu

## 13.1.3. Please solder under the following condition.

## ① Flow Solder

Preheating :  $120\pm 10^{\circ}\text{C}$  60~120seconds

Soldering temperature :  $260^{\circ}\text{C}$   $+0^{\circ}\text{C}/-5^{\circ}\text{C}$

Soldering time : 10 seconds max.

## ② Condition of iron Soldering

Preheating :  $120\pm 10^{\circ}\text{C}$  30 minutes max

Iron temperature :  $350^{\circ}\text{C}$  max

Soldering time : 3 seconds max

## 13.1.4. Recommendable Solder Land Pattern

Pin No	Pin Size	Hole diameter	Land diameter
1.Vin(+) 2.ON/OFF 3.Vin(-) 5.Vsens(-) 6.Trim 7.Vsens(+)	$\phi 1.02$	$\phi 1.5$	$\phi 3.0$
4.Vout(-) 8.Vout(+)	$\phi 1.57$	$\phi 2.0$	$\phi 4.0$

[Unit:mm]

## Recommended footprint

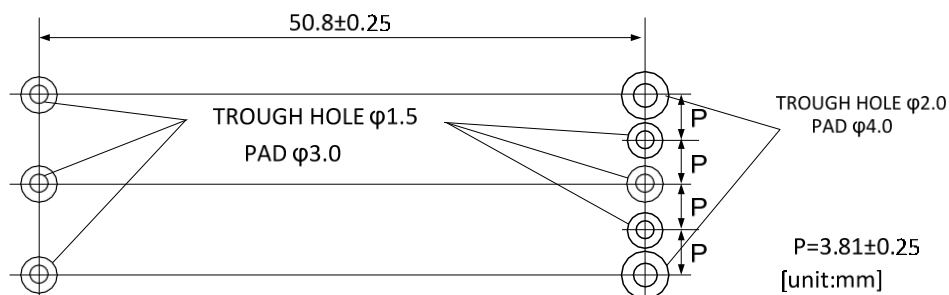

$P=3.81\pm 0.25$   
[unit:mm]

**△Note:**

1. This datasheet is downloaded from the website of Murata Manufacturing co., ltd. Therefore, it's specifications are subject to change or our products in it may be discontinued without advance notice. Please check with our sales representatives or product engineers before ordering.
2. This datasheet has only typical specifications because there is no space for detailed specifications. Therefore, please approve our product specifications or transact the approval sheet for product specifications before ordering.

### 13.2. Cleaning

Please don't clean or wash the products.

### 13.3. Storage

13.3.1. Please store the products in room where the temperature/humidity is stable and direct sunlight cannot come in and use the products within 6 months after delivery.

Avoid damp heated places or such places where there are large temperature changes, because water may condense on the products, the characteristics may be reduced in quality, and/or be degraded in the solderability.

If you store the products for a long time (more than 1 year), use caution because the products may be degraded in the solderability and/or rusty.

Please confirm solderability and characteristics for the products regularly.

13.3.2. Please do not store the products in the places such as:

in a dusty place, in a place exposed directly to sea breeze, in an atmosphere containing corrosive gas (Cl<sub>2</sub>, NH<sub>3</sub>, SO<sub>2</sub>, NO<sub>x</sub> and so on).

### 13.4. Operational Environment and Operational Conditions

#### 13.4.1. Operational Environment

The products are not waterproof, chemical-proof or rustproof.

In order to prevent leakage of electricity and abnormal temperature increase of the products, do not use the products under the following circumstances:

- (1) in an atmosphere containing corrosive gas (Cl<sub>2</sub>, NH<sub>3</sub>, SO<sub>2</sub>, NO<sub>x</sub> and so on)
- (2) in a dusty place
- (3) in a place exposed to direct sunlight
- (4) in such a place where water splashes or in such a humid place where water condenses
- (5) in a place exposed to sea breeze
- (6) in any other places similar to the above (1)through (5)

#### 13.4.2. Operational Conditions

Please use the products within specified values (power supply, temperature, input, output and load condition, and so on). Input voltage drop for line impedance, so please make sure that input voltage is included in specified values. If you use the products over the specified values, it may break the products, reduce the quality, and even if the products can endure the condition for short time, it may cause degradation of the reliability.

#### 13.4.3. Note prior to use

If you apply high static electricity, over rated voltage or reverse voltage to the products, it may cause defects in the products or degrade the reliability.

Please avoid the following items:

- (1) over rating power supply, reverse power supply or not-enough connection of 0 V(DC)line
- (2) electrostatic discharge by production line and/or operator
- (3) electrified product by electrostatic induction

Do not give an excessive mechanical shock.

If you drop the products on the floor, etc., it may occur a crack to the core of inductors and monolithic ceramic capacitors.

Do not give a strong shock such as a drop in handling.

Do not bend this product much more than 0.1mm.

#### △Note:

1. This datasheet is downloaded from the website of Murata Manufacturing co., ltd. Therefore, it's specifications are subject to change or our products in it may be discontinued without advance notice. Please check with our sales representatives or product engineers before ordering.
2. This datasheet has only typical specifications because there is no space for detailed specifications. Therefore, please approve our product specifications or transact the approval sheet for product specifications before ordering.

### 13.5. Transportation

If you transport the products, please pack them so that the package will not be damaged by mechanical vibration or mechanical shock, and please educate and guide a carrier to prevent rough handling.

If you transport the products to overseas (in particular, by sea), it is expected that the transportation environment will be the worst, so please pack the products, in the package designed on the consideration of mechanical strength, vibration-resistant and humidity-resistant.

The package of the products, which Murata sells in Japan, may not resist over sea transport.

Please consult us if you are to use the Murata package of the products sold in Japan for transport to overseas.

### 14. Production factory

Wakura Murata Manufacturing Co., Ltd.

Murata Electronics(Thailand), Ltd.

### ⚠ Caution

1. Be sure to provide an appropriate fail-safe function on your product to prevent a second damage that may be caused by the abnormal function or the failure of our product.
2. Please connect the input terminal by right polarity. If you mistake the connection, it may break the DC-DC converter. In the case of destruction of the DC-DC converter inside, a large input current may flow. Please add a diode and fuse as follows.

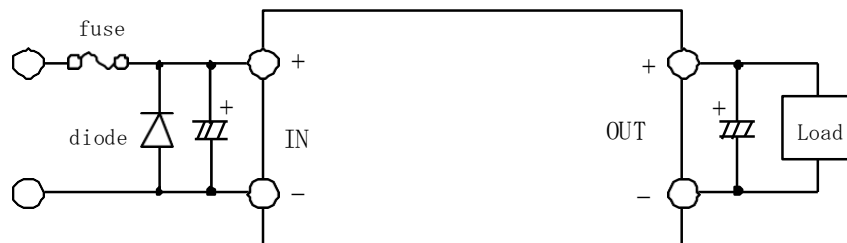

Rated Fuse Current : 12A

Please select a diode and fuse after confirming the operation.

### 3. The intended use

3.1. This product is designed/manufactured for the general applications such as computers, office appliances, communication equipment, machine tools, factory equipment, audiovisual equipment and home appliances, etc.

3.2. Please contact us before using this product for the applications, which require high reliability, such as transportation equipment (aircraft, trains, vehicles, etc.), traffic lights equipment, disaster prevention/crime prevention equipment, etc.

3.3. Please do NOT use this product for the applications which require especially high reliability, such as aerospace equipment, undersea equipment, nuclear power plant control equipment, medical equipment, etc.

### ⚠Note:

1. This datasheet is downloaded from the website of Murata Manufacturing Co., Ltd. Therefore, it's specifications are subject to change or our products in it may be discontinued without advance notice. Please check with our sales representatives or product engineers before ordering.
2. This datasheet has only typical specifications because there is no space for detailed specifications. Therefore, please approve our product specifications or transact the approval sheet for product specifications before ordering.

**Note**

1. Please make sure that your product has been evaluated and confirmed against your specifications when our product is mounted to your product.
2. All the items and parameters in this product specification have been prescribed on the premise that our product is used for the purpose, under the condition and in the environment agreed upon between you and us.  
You are requested not to use our product deviating from such agreement.
3. We consider it not appropriate to include other terms and conditions for transaction warranty in product specifications, drawings or other technical documents.  
Therefore, if your technical documents as above include such terms and conditions as warranty clause, product liability clause, or intellectual property infringement liability clause, we will not be able to accept such terms and conditions unless they are based on the governmental regulation or they are stated in a separate contract agreement.

**△Note:**

1. This datasheet is downloaded from the website of Murata Manufacturing Co., Ltd. Therefore, it's specifications are subject to change or our products in it may be discontinued without advance notice. Please check with our sales representatives or product engineers before ordering.
2. This datasheet has only typical specifications because there is no space for detailed specifications. Therefore, please approve our product specifications or transact the approval sheet for product specifications before ordering.