

To be discontinued

# NM232DDC Series

Isolated Dual EIA-232-D Transmitter and Receiver



## FEATURES

- RoHS compliant
- Single 5V supply
- 50μW low power shutdown
- TTL/CMOS Logic compatible
- EIA-232-D/E and CCITT V.28 compatible
- Dual transmitters and receivers
- 1.5kVrms Isolation

## DESCRIPTION

The NM232DDC is an electrically isolated dual transmitter and receiver designed to interface data terminal equipment (DTE) with data communications equipment (DCE). The device provides two data receive channels and two data transmit channels. Each channel is EIA-232-D, EIA-232-E and CCITT V.28 compatible at the interface boundary and TTL/CMOS compatible at the logic connections. No external components are needed and a single 5V input supply powers all functions either side of the isolation boundary. A low-power shutdown mode and high impedance state for receiver outputs is effected via two pins, SHUTDOWN and ENABLE. The device is supplied in a low profile 24 pin DIP package.

## ELECTRICAL CHARACTERISTICS

Parameter	Test conditions	Min..	Typ.	Max.	Units
High threshold input logic, $V_{IH}$	$TX_{IN}$ , SHUTDOWN, $\overline{ENABLE}$		1.8	2.4	V
Low threshold input logic, $V_{IL}$	$TX_{IN}$ , SHUTDOWN, $\overline{ENABLE}$	0.8	1.3		V
Input Hysteresis, $\Delta V_T$	$TX_{IN}$		0.5		V
Leakage Current, $I_L$	$TX_{IN}$ , SHUTDOWN or $\overline{ENABLE} = V_{CC}$			10	μA
Input capacitance, $C_{IN}$	$TX_{IN}$		5.0		pF
Low level output voltage, $V_{OL}$	$I_{OUT} = 3.2mA$			0.4	V
High level output voltage, $V_{OH}$	$I_{OUT} = -1.0mA$	2.4			V
Input pull up current	$V_{IN} = 0V$		4.0	20	μA
$\pm V_{REF}$ Current	$TX_{OUT} = 3k\Omega$ , $RX_{OUT} = 2.2k\Omega$			3.0	mA

## ELECTRICAL CHARACTERISTICS - EIA-232-D

Parameter	Test conditions	Min..	Typ.	Max.	Units
Positive going threshold, $V_{T+}$	$RX_{IN}$		1.8	3.0	V
Negative going threshold, $V_{T-}$	$RX_{IN}$	0.6	1.2		V
Input Hysteresis, $\Delta V_T$	$RX_{IN}$		0.6		V
Input resistance	$RX_{IN}$	3.0		7.0	kΩ
Output voltage, $V_{FP}$	$TX_{OUT}$ , $R_L = 3k\Omega$ to ISO GND	±5.0	±7.0		V
Output leakage current, $I_L$	SHUTDOWN= $V_{CC}$ , $TX_{OUT} = \pm 15V$	-10		10	μA
Output slew rate, $S_R$	$R_L = 3k\Omega$ , $C_L = 2500pF$		3.0	30	V/μs
Propagation delay, $T_L$	Logic to RS232		20		μs
Propagation delay, $T_R$	RS232 to logic		10		μs
Transmission rate	$R_L = 3k\Omega$ , $C_L = 2500pF$			9.6	kbps
Supply voltage, $V_{CC}$		4.5		5.5	V
Supply current, $I_{CC}$	$TX_{IN} = 0.8V$ , $TX_{OUT} = 3k\Omega$ , $RX_{IN} = 3.0V$ , $RX_{OUT} = 2.2k\Omega$		53		mA
Shutdown current $I_{CC}$	SHUTDOWN=1		1.0	10	μA
$\overline{ENABLE}$ input current, $I_{EN}$	$\overline{ENABLE} = 0V$ to $V_{CC}$			1.0	μA
Shutdown input current, $I_{SHUTDOWN}$	SHUTDOWN=0V to $V_{CC}$			1.0	μA
MTTF <sup>1</sup>		187			kHrs

## TEMPERATURE CHARACTERISTICS

Parameter	Min..	Typ.	Max.	Units
Operating free-air temperature range	0		70	°C
Storage temperature range	-55		125	°C

## ABSOLUTE MAXIMUM RATINGS

Supply voltage $V_{CC}$ with respect to pin 10	-0.3V to +6V	
Input voltage to logic pins 3, 7, 8, & 11 with respect to pin 10	-0.3V to $V_{CC} + 0.3V$	
Voltages with respect to ISO GND pin 22	EIA-232-D input voltage, pins 17 & 18	-30V to +30V
	EIA-232-D input voltage, pins 19 & 20	-15V to +15V
	Positive input voltage, pins 16 & 21	+14V
Negative input voltage, pin 23	-14V	
Short circuit on pins 19 & 20	Indefinite	
Power dissipation	700mW	
NM232DDC maximum data rate	9.6kbps	
Lead case temperature 1.5mm from case for 10 seconds	260°C	

## ISOLATION CHARACTERISTICS

Parameter	Conditions	Min..	Typ.	Max.	Units
Isolation test voltage	Flash tested for 1 second	1500			Vrms

1. Calculated using MIL-HDBK-217F.  
All data taken at  $T_A = 25^\circ C$ ,  $V_{CC} = 5V$ .



For full details go to  
[www.murata-ps.com/rohs](http://www.murata-ps.com/rohs)

### APPLICATION NOTES

The NM232DDC is an isolated interface device providing EIA-232-D compatibility. A single supply from the logic side provides all necessary power for the device. The isolation feature allows the protective or frame ground of DTEs or DCEs to be isolated from each other, eliminating ground loop currents and inherently long noise paths. The voltage level between different ground points can be up to  $\pm 5V$  or  $\pm 6V$  and this level fluctuates as the power taken varies. This voltage appears, in non-isolated equipment, as normal mode noise on the signals. With such high noise levels present it is clearly very difficult with single ended signals to have reliable communication. Isolating the input from output so that one side floats relative to the other allows reliable communication in environments with considerable degrees of noise between equipments.

Figure 1 shows a typical pcb track layout with a clear separation between the logic pin connections (pins 1-12) and the EIA-232-D connections (pins 13-24). Between the two sides of the layout is a track which can be connected to frame or equipment ground, this can be seen as the boundary between the logic and EIA-232-D side of the device. No other rules or speed conditions need to be applied other than to keep the two halves' separation to a maximum.

An example of a DTE application circuit is shown in figure 2. The schematic is illustrative of the way the NM232DDC may be connected to implement an isolated EIA-232-D interface with a typical UART and processor bus. Precise circuitry will depend on the application and in particular the use of the control lines shown will need to be altered to suit the situation.

The ENABLE control line (pin 11), puts the receiver output pins 1 and 12 into a high impedance state when set to a high level. The shutdown control line (pin 3) sets the device into a shutdown power mode when it is at high logic level. The maximum power drawn in shutdown mode is  $50\mu W$ , a low enough level for consideration in battery powered equipment.

#### Where to use the NM232DDC

The function of the NM232DDC is to provide an isolated signal path between a UART or similar device and the EIA-232-D interface 'D' connector, providing two receivers and two transmitters which can be used in a number of handshake modes. One receiver and transmitter will normally be used for the signal lines and the remaining pair will act as handshake lines. Figure 3 shows simply where the device will be connected.

More complicated schemes for controlled signal interchange will require two or more such devices. As the devices are self contained no external DC/DC converter is required. The enable line provides a means for creating a communications bus where each NM232DDC can have a different logical address via a decoder. This would allow one UART to talk with many EIA-232-D connected interfaces (see figure 4).

Figure 1

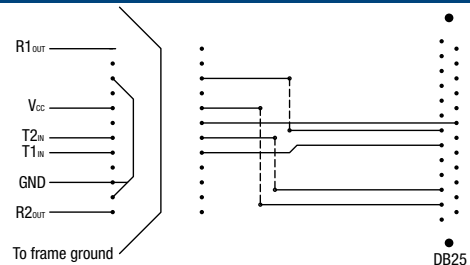

Figure 2

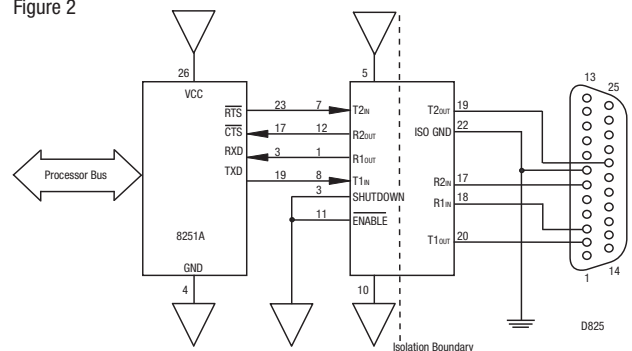

Figure 3

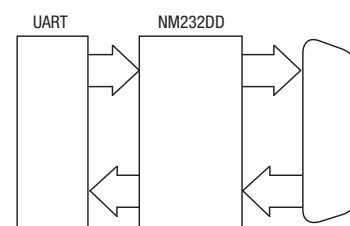
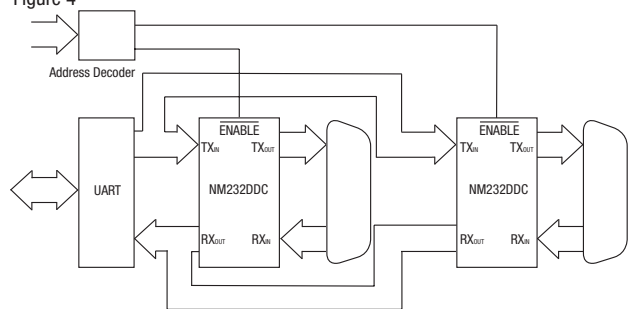

Figure 4



### RoHS COMPLIANCE INFORMATION



This series is compatible with RoHS soldering systems with a peak wave solder temperature of 260°C for 10 seconds. Please refer to [application notes](#) for further information. The pin termination finish on this product series is Matte Tin over Nickel Preplate. The series is backward compatible with Sn/Pb soldering systems. For further information, please visit [www.murata-ps.com/rohs](http://www.murata-ps.com/rohs)

**TYPICAL OPERATING CHARACTERISTICS**

**POWER UP TO TRANSMITTER OUTPUT DELAY**

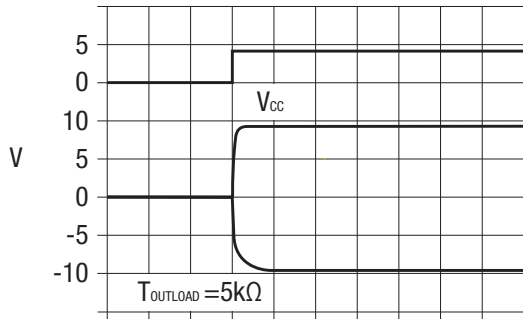

1 ms/div

**SHUTDOWN TO POWER UP DELAY**

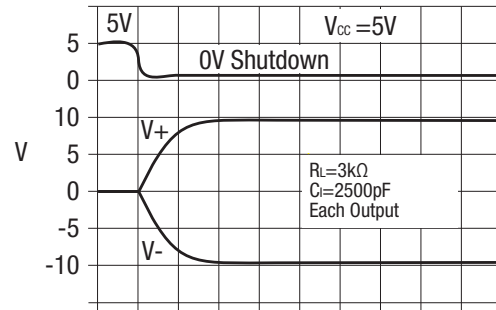

500ms/div

**TRANSMITTER SLEW RATE VS LOAD CAPACITANCE**

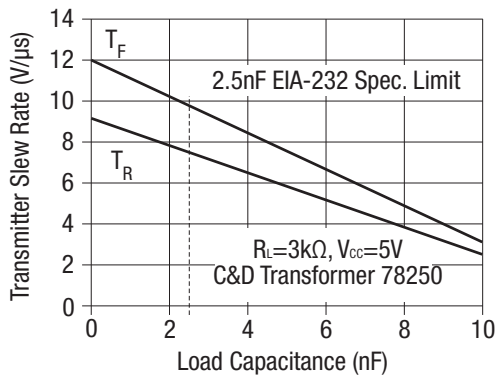

**TRANSMITTER SLEW RATE VS TEMPERATURE**

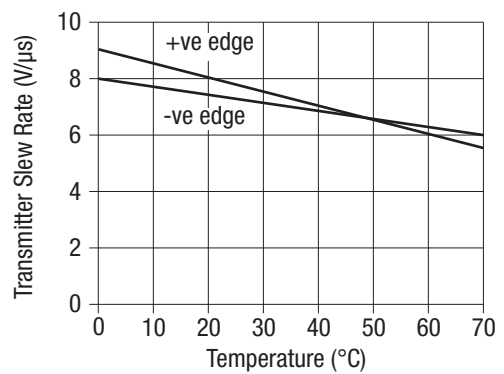

**ENABLE & DISABLE TIMES VS TEMPERATURE**

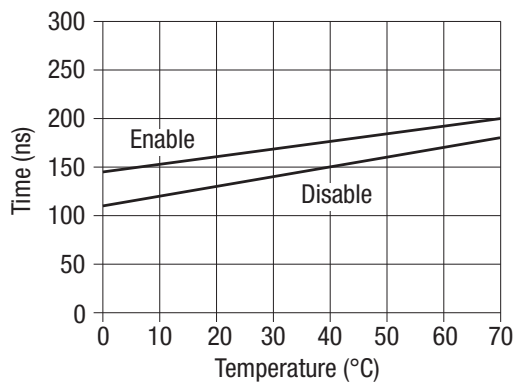

**PROPAGATION DELAY VS TEMPERATURE**

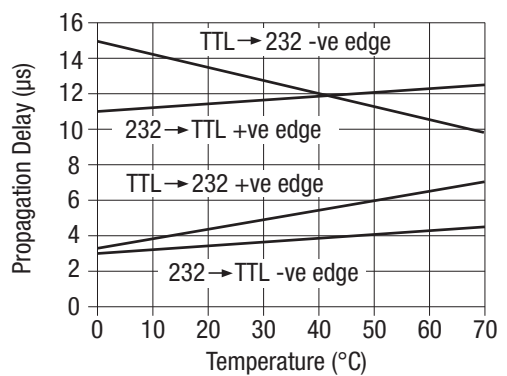

**PACKAGE SPECIFICATIONS**

**MECHANICAL DIMENSIONS**

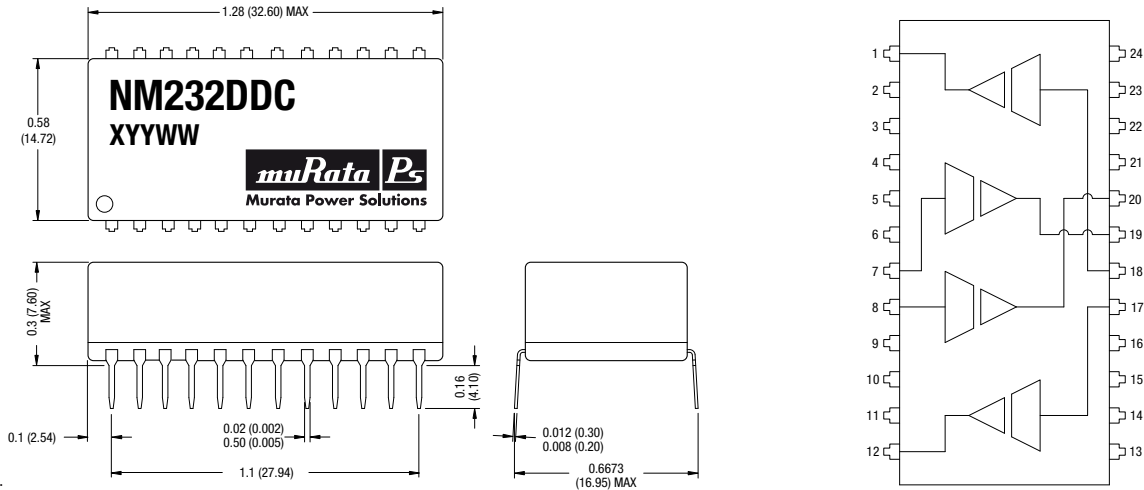

Weight: 5.5g Typ.  
All pins on a 0.1 (2.54) pitch.  
All dimensions are in inches (mm) ±0.01 (0.25).

**PIN CONNECTIONS**

Pin	Function	Description
1	R1 <sub>OUT</sub>	Receiver output number 1, TTL/CMOS logic
2	NC	No internal connection
3	SHUTDOWN	SHUTDOWN input, High=SHUTDOWN, Low=normal operation
4	NC	No internal connection
5	V <sub>CC</sub>	+5V supply
6	NC	No internal connection
7	T2 <sub>IN</sub>	Transmitter input number 2, TTL/CMOS logic
8	T1 <sub>IN</sub>	Transmitter input number 1, TTL/CMOS logic
9	NC	No internal connection
10	GND	Ground
11	ENABLE	Output ENABLE, High-Hi Z on R1/R2 <sub>OUT</sub> , low-normal operation
12	R2 <sub>OUT</sub>	Receiver output number 2, TTL/CMOS logic
13	NC	No internal connection
14	NC	No internal connection
15	NC	No internal connection
16	+V <sub>REF</sub>	Isolated +V supply out internally connected to pin 12
17	R2 <sub>IN</sub>	Receiver input number 2, RS232 levels
18	R1 <sub>IN</sub>	Receiver input number 1, RS232 levels
19	T2 <sub>OUT</sub>	Transmitter output number 2, RS232 levels
20	T1 <sub>OUT</sub>	Transmitter output number 1, RS232 levels
21	+V <sub>REF</sub>	Isolated +V supply out internally connected to pin 16
22	ISO GND	Isolated ground
23	-V <sub>REF</sub>	Isolated +V supply out-
24	NC	No internal connection

**RECOMMENDED FOOTPRINT**

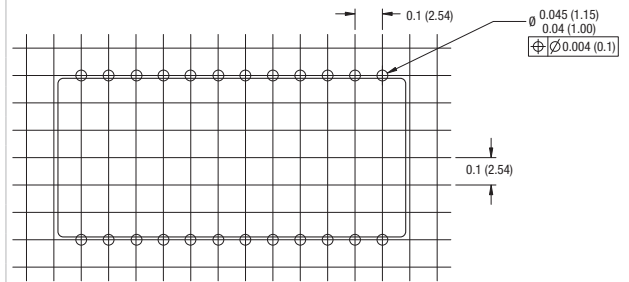

All dimensions are in inches (mm) ±0.01 (0.25)

**TUBE OUTLINE DIMENSIONS**

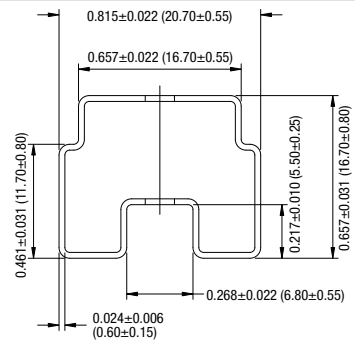

All dimensions are in inches (mm) ±0.01 (0.25)

Tube Quantity : 15

### TECHNICAL NOTES

#### ISOLATION VOLTAGE

'Hi Pot Test', 'Flash Tested', 'Withstand Voltage', 'Proof Voltage', 'Dielectric Withstand Voltage' & 'Isolation Test Voltage' are all terms that relate to the same thing, a test voltage, applied for a specified time, across a component designed to provide electrical isolation, to verify the integrity of that isolation.

Murata Power Solutions NM232DDC series of DC/DC converters are all 100% production tested at their stated isolation voltage. This is 1.5kVrms for 1 second.

A question commonly asked is, "What is the continuous voltage that can be applied across the part in normal operation?"

For a part holding no specific agency approvals, such as the NM232DDC series, both input and output should normally be maintained within SELV limits i.e. less than 42.4V peak, or 60VDC. The isolation test voltage represents a measure of immunity to transient voltages and the part should never be used as an element of a safety isolation system. The part could be expected to function correctly with several hundred volts offset applied continuously across the isolation barrier; but then the circuitry on both sides of the barrier must be regarded as operating at an unsafe voltage and further isolation/insulation systems must form a barrier between these circuits and any user-accessible circuitry according to safety standard requirements.

#### REPEATED HIGH-VOLTAGE ISOLATION TESTING

It is well known that repeated high-voltage isolation testing of a barrier component can actually degrade isolation capability, to a lesser or greater degree depending on materials, construction and environment. The NM232DDC series has toroidal isolation transformers, with no additional insulation between primary and secondary windings of enameled wire. While parts can be expected to withstand several times the stated test voltage, the isolation capability does depend on the wire insulation. Any material, including this enamel (typically polyurethane) is susceptible to eventual chemical degradation when subject to very high applied voltages thus implying that the number of tests should be strictly limited. We therefore strongly advise against repeated high voltage isolation testing, but if it is absolutely required, that the voltage be reduced by 20% from specified test voltage.

### DISCLAIMER

Unless otherwise stated in the datasheet, all products are designed for standard commercial and industrial applications and NOT for safety-critical and/or life-critical applications.

Particularly for safety-critical and/or life-critical applications, i.e. applications that may directly endanger or cause the loss of life, inflict bodily harm and/or loss or severe damage to equipment/property, and severely harm the environment, a prior explicit written approval from Murata is strictly required. Any use of Murata standard products for any safety-critical, life-critical or any related applications without any prior explicit written approval from Murata shall be deemed unauthorised use.

These applications include but are not limited to:

- Aircraft equipment
- Aerospace equipment
- Undersea equipment
- Power plant control equipment
- Medical equipment
- Transportation equipment ( automobiles, trains, ships, etc.)
- Traffic signal equipment
- Disaster prevention / crime prevention equipment
- Data Processing equipment

Murata makes no express or implied warranty, representation, or guarantee of suitability, fitness for any particular use/purpose and/or compatibility with any application or device of the buyer, nor does Murata assume any liability whatsoever arising out of unauthorised use of any Murata product for the application of the buyer. The suitability, fitness for any particular use/purpose and/or compatibility of Murata product with any application or device of the buyer remain to be the responsibility and liability of the buyer.

Buyer represents and agrees that it has all the necessary expertise to create and implement safeguards that anticipate dangerous consequences of failures, monitor failures and their consequences, lessen the likelihood of failures that might cause harm, and take appropriate remedial actions. Buyer will fully indemnify and hold Murata, its affiliated companies, and its representatives harmless against any damages arising out of unauthorised use of any Murata products in any safety-critical and/or life-critical applications.

Remark: Murata in this section refers to Murata Manufacturing Company and its affiliated companies worldwide including, but not limited to, Murata Power Solutions.



This product is subject to the following [operating requirements](#) and the [Life and Safety Critical Application Sales Policy](#):

Refer to: <https://www.murata.com/en-eu/products/power/requirements>

Murata Power Solutions (Milton Keynes) Ltd. makes no representation that the use of its products in the circuits described herein, or the use of other technical information contained herein, will not infringe upon existing or future patent rights. The descriptions contained herein do not imply the granting of licenses to make, use, or sell equipment constructed in accordance therewith. Specifications are subject to change without notice.

© 2021 Murata Power Solutions (Milton Keynes) Ltd.