



FEATURES

- UL62368-1 recognised
- EN62368-1 certified
- ANSI/AAMI ES60601-1, 1 MOPP/2 MOOP's recognition pending
- Wide input voltage range 85-264VAC/ 120-370VDC
- Operating temperature range -40°C to 85°C
- 4.25kVDC isolation 'Hi Pot Test'
- 3.3V, 5V, 12V & 24V single regulated outputs
- Over current protection
- Short circuit protection
- Meets EMC class B with no external components

PRODUCT OVERVIEW

The BAC10 series delivers an output power of 10 watts from -40°C to 55°C, operating up to 85°C with derating, from AC or DC input voltages. The BAC10 series small footprint is EMC class B compliant without the need of any external components. The BAC10 series is suited to medical applications with 1 MOPP and 2 MOOP.

With high efficiency at low loads and low no load power consumption, the BAC10 supports standby mode operation for applications in industrial, medical, automation, IOT as well as household and home automation.

BAC10 Series

Isolated 10W Regulated Single Output AC/DC Converters

SELECTION GUIDE

Order Code ¹	Output Power W	Output Voltage V	Output Current A	Ripple & Noise				Efficiency				Isolation Capacitance pF	MTTF ²	
				115V		230V		115V		230V			MIL 217	Telcordia
				Typ.	Max.	Typ.	Max.	Min.	Typ.	Min.	Typ.			
				mVp-p				%					kHrs	
BAC10S03DC	6.6	3.3	2	40	80	50	80	70	73	70	73	170	337	5207
BAC10S05DC	10	5	2	50	80	50	80	75	77.5	75	79	170	276	2357
BAC10S12DC	10	12	0.83	50	120	65	120	77	80.5	78	82	170	304	2937
BAC10S24DC	10	24	0.42	60	200	85	200	79	83	80	83.5	170	344	4277

To be discontinued

INPUT CHARACTERISTICS

Parameter	Conditions	Min.	Typ.	Max.	Units
Voltage range	All input types	85	115/230	264	VAC
	All input types	120		370	VDC
Input frequency		47	50/60	63	Hz
Switching frequency			79		kHz
Input current	Nominal Vin = 115VAC	BAC10S03DC		150	mA
		BAC10S05DC		200	
		BAC10S12DC		190	
		BAC10S24DC		190	
	Nominal Vin = 230VAC	BAC10S03DC		100	
		BAC10S05DC		130	
		BAC10S12DC		120	
		BAC10S24DC		120	
Inrush current	Nominal Vin = 115VAC		11	A	
	Nominal Vin = 230VAC		25		
Input leakage current	250VAC		25	µA	
Stand by power	BAC10S03DC	115VAC		66	mW
		230VAC		74	
	BAC10S05DC	115VAC		97	
		230VAC		104	
	BAC10S12DC	115VAC		83	
		230VAC		91	
	BAC10S24DC	115VAC		202	
		230VAC		210	



1. 6 pin variant available - Orderable part numbers are BAC10SxxD6C, for further information refer to the application notes.
 2. Calculated using MIL-HDBK-217F FN2 and Telcordia SR-332, parts stress method with nominal input voltage 115VAC at full load.
 3. ANSI/AAMI ES60601-1 recognition is currently pending
 All specifications typical at T_A=25°C, nominal input voltage and rated output current unless otherwise specified.

ISOLATION CHARACTERISTICS							
Parameter	Conditions		Min.	Typ.	Max.	Units	
Isolation test voltage	Production tested for 1 second		4250			VDC	
	Qualification tested for 1 minute		4250				
Resistance	Viso = 1000VDC		100			MΩ	
Safety approvals ³	UL62368-1	Reinforced	Creepage and clearance 8.6mm			240	VAC
	EN62368-1					240	
	ANSI/AAMI ES60601-1				1 MOPP/2 MOOP		

OUTPUT CHARACTERISTICS							
Parameter	Conditions		Min.	Typ.	Max.	Units	
Minimum load			10			%	
Initial voltage accuracy	All output types				±3	%	
Line regulation	Low line to high line	BAC10S03DC		±0.13	±0.5	%	
		BAC10S24DC		±0.03	±0.5		
		All others		±0.04	±0.5		
Load Regulation	10% total load to 100% total load	115VAC	BAC10S03DC		±0.12	±1	%
			BAC10S05DC		±0.5	±1	
			BAC10S12DC		±0.02	±1	
		230VAC	BAC10S24DC		±0.07	±1	
			BAC10S03DC		±0.06	±1	
			BAC10S05DC		±0.4	±1	
Temperature coefficient					0.05	%/°C	
	Transient Response	Peak deviation - 50-75% & 75-50% swing	115VAC	3.3V & 5V output types		±2	%Vout
				12V & 24V output types		±1	
	Settling time (within 1% Vout Nom.)	230VAC	3.3V & 5V output types		±0.5	μs	
			12V & 24V output types		0		
Current limit inception	Hiccup	BAC10S03DC			110	%	
		BAC10S05DC			110		
		BAC10S12DC			115		
		BAC10S24DC			120		
Hold up time	115VAC				15	ms	
	230VAC				75		

TEMPERATURE CHARACTERISTICS						
Parameter	Conditions		Min.	Typ.	Max.	Units
Operation	Please refer to derating graphs	Convection cooling 0.2m/s	-40		85	°C
Storage			-40		85	
Product temperature rise above ambient	BAC10S05DC			35		
	BAC10S12DC			30		
	All others			25		

ABSOLUTE MAXIMUM RATINGS	
Short-circuit protection ¹	Continuous, auto recovery
Input voltage	277VAC
Lead temperature 1.0mm from case for 7 +2/-0 seconds (to JEDEC JESD22-B106)	270 ±5°C
Shelf life (1 year)	Please refer to reconditioning application notes.
Wave solder	Wave Solder profile not to exceed the profile recommended in IEC 61760-1 Section 6.1.3. Please refer to application notes for further information.

1. Please see application notes for more details.

TECHNICAL NOTES

ISOLATION VOLTAGE

'Hi Pot Test', 'Flash Tested', 'Withstand Voltage', 'Proof Voltage', 'Dielectric Withstand Voltage' & 'Isolation Test Voltage' are all terms that relate to the same thing, a test voltage, applied for a specified time, across a component designed to provide electrical isolation, to verify the integrity of that isolation.

Murata Power Solutions BAC10 series of AC/DC converters are all 100% production tested at their stated isolation voltage. This is 4.25kVDC for 1 second.

A question commonly asked is, "What is the continuous voltage that can be applied across the part in normal operation?"

The BAC10 series is pending recognition by Underwriters Laboratory to 240VAC for Reinforced Insulation.

The BAC10 series fulfils the requirements of EN62368-1:2014 + A11:2017 to 240VAC for Reinforced Insulation.

REPEATED HIGH-VOLTAGE ISOLATION TESTING

It is well known that repeated high-voltage isolation testing of a barrier component can actually degrade isolation capability, to a lesser or greater degree depending on materials, construction and environment. We therefore strongly advise against repeated high voltage isolation testing, but if it is absolutely required, that the voltage be reduced by 20% from specified test voltage.

SAFETY APPROVAL

ANSI/AAMI ES60601-1

The BAC10 series is pending recognition by Underwriters Laboratory (UL) to ANSI/AAMI ES60601-1 and provides 1 MOPP (Means Of Patient Protection) and 2 MOOP (Means Of Operator Protection) based upon a working voltage of 240VAC max., between Primary and Secondary. File number E202895 applies.

EN62368-1

The BAC10 series fulfils the requirements of EN62368-1:2014 + A11:2017 for reinforced insulation to a working voltage of 240VAC.

UL62368

The BAC10 series has been recognised by Underwriters Laboratory (UL) to UL62368 for reinforced insulation to a working voltage of 240VAC. File number E151252 applies.

Creepage and clearance 8.6mm

Working altitude OVC II 5000m

RoHS COMPLIANCE INFORMATION



This series is compatible with RoHS soldering systems with a peak wave solder temperature of 260°C for 10 seconds based on IEC 61760-1. Please refer to [application notes](#) for further information. The pin termination finish on this product series is Hot Dipped over Matte Tin with Nickel Preplate. The series is backward compatible with Sn/Pb soldering systems. For further information, please visit www.murata.com/en-global/products/rohs

ENVIRONMENTAL VALIDATION TESTING

The following tests have been conducted on this product series, as part of our design verification process. The datasheet characteristics specify user operating conditions for this series, please contact Murata if further information about the tests is required.

Test	Standard	Condition
Temperature Cycling	JEDEC JESD22-A104	200 cycles. -40°C to 105°C, 15 minutes hold at each extreme including transitions.
Humidity bias	JEDEC JESD22-A101	85±2°C, 85±5% R.H. for 1000 (+168/-24) hours
Storage life	JEDEC JESD22-A103	105°C +10/-0°C for ≥1000 hours
Vibration	BS EN 61373 with respect to BS EN 60068-2-64, Test Fh Category 1 Class B	5 – 150Hz. Level at each axis – Vertical, Traverse and Longitudinal: 5.72m/s ² rms. 5 hours in each axis. Crest factor: 3 Sigma. Device is secured via pins/leads.
Shock	BS EN 61373: Category 1 Class B	Test is 30ms duration, 3 shocks in each sense of 3 mutually perpendicular axes (18 shocks total). Level at each axis as follows: Vertical, Traverse and Longitudinal: 50m/s ² . Device is secured via pins.
Solderability	EIA/IPC/ECA J-STD-002 Test A1	Parts are baked for 4 hours at a temperature of 155°C, within 72 hours they are dipped in flux for 10 seconds. Followed by dipping the parts in a solder pot at 255°C ±5°C for 5 seconds (96SC tin/silver/copper)
Solvent cleaning	Resistance to cleaning agents	Solvent – Novec 71IPA & Topklean EL-20A. Pulsed ultrasonic immersion 45°C- 65°C
Solvent resistance	MIL-STD-883 Method 2015	The parts and the bristle portion of the brush are immersed in Isopropanol for a minimum of 1 minute. The parts are brushed 3 times, after the third time the parts are blown dry and inspected.
Solder Heat	JEDEC JESD22-B106	The test sample is subjected to a molten solder bath at 270 ±5°C for 7 +2/-0 seconds (96SC tin/silver/copper). The leads are dipped in the solder bath to within 1mm of the device body.
Solder Heat (Hand)	MIL-STD 202 Method 210, Condition A	The soldering iron is heated to 350°C ± 10°C and applied to the terminations for a duration of 4 to 5 seconds.
Lead Integrity (Adhesion)	MIL-STD 883 Method 2025	Leads are bent through 90° until a fracture occurs.
Lead Integrity (Fatigue)	MIL-STD 883 Method 2004, Condition B ₂	The leads are bent to an angle of 15°. Each lead is subjected to 3 cycles.
Lead Integrity (Tension/Pull)	MIL-STD 883 Method 2004, Condition A ₁	Pull of 0.227kg applied for 30 seconds. The force is then increased until the pins snap.

EMC/ESD STANDARDS

Conducted emissions	EN55032/FCC class B
Radiated emissions	EN55032/FCC class B
ESD immunity	IEC/EN 61000-4-2, level 1, criteria A
Radiated, radio-frequency, electromagnetic field immunity	IEC/EN61000-4-3, 10V/m perf criteria A 10V/m 80-1000MHz 3V/m 1.4-2.0GHz 1V/m 2.0-2.7GHz All 80% 1kHz am mod all perf criteria A
EFT/burst	IEC/EN61000-4-4, 2kV, perf criteria A
Surge immunity	IEC/EN61000-4-5, 1kV perf criteria A
Conducted field immunity	IEC/EN61000-4-6, 10 Vrms 0.15-80MHz 80% 1kHz am mod perf criteria A
Power frequency magnetic field immunity	IEC/EN61000-4-8 50Hz/60Hz 30 A/m perf criteria A
Harmonic current emissions	IEC/EN61000-3-2
Voltage changes, voltage fluctuations and flicker	IEC/EN61000-3-3
Voltage dips, short interruptions and variations	IEC/EN61000-4-11, 100% for 20ms, 60% for 200ms, 30% for 500ms and 100% for 5s perf criteria A-A-A-C.

PART NUMBER STRUCTURE

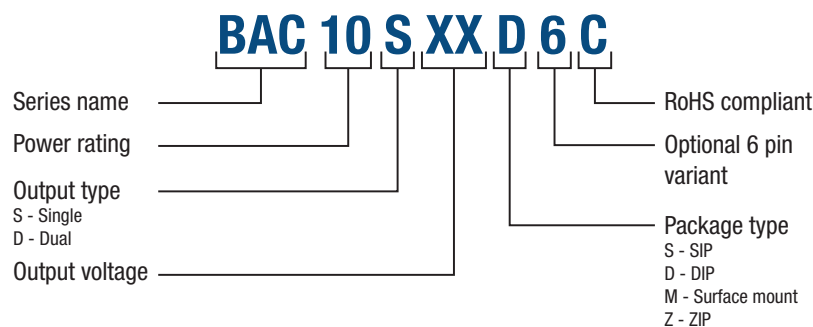

CHARACTERISATION TEST METHODS

Ripple & Noise Characterisation Method

Ripple and noise measurements are performed with the following test configuration.

C1 10 μ F electrolytic capacitor

Differential Mode Noise Test Schematic

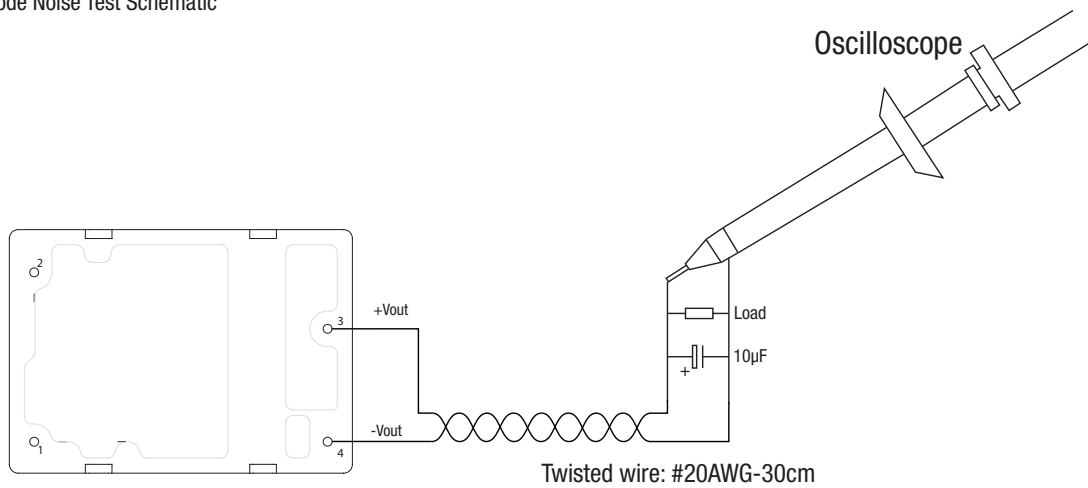

APPLICATION NOTES

Output Capacitance and start-up times

The BAC10 series does not require output capacitors to meet datasheet specification. To meet datasheet specification, output capacitance should not exceed:

Part No.	Maximum Load Capacitance (per output) μ F	Start-up times	
		115VAC	230VAC
		ms	
BAC10S03DC	1000	500	200
BAC10S05DC	1000	500	200
BAC10S12DC	440	500	200
BAC10S24DC	220	500	200

When operational in an application will operate down to -40°C. For start-up below nominal input voltage \leq 115VAC, at very low temperatures, please refer the temperature derating graphs.

Minimum Load

The minimum load to meet full datasheet specification is 10% of the full rated load across the specified input voltage range.

Reconditioning

This series contains electrolytic capacitors, which require reconditioning if the product is stored non-powered for more than 2 years from the date of manufacture. To recondition the capacitors, an AC input voltage should be applied with output loading for 10 minutes. For further information please contact Murata.

APPLICATION NOTES (Continued)

BAC10 optional 6 pin variants

An external 27uF electrolytic may be fitted to enable start up at -40°C , with minimum input voltage into 100% load.

C1 27uF electrolytic capacitor

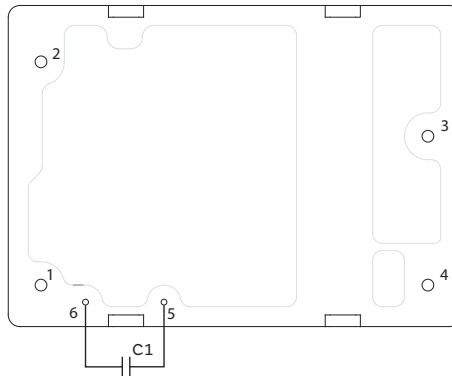

EFFICIENCY VS LOAD

BAC10S03DC

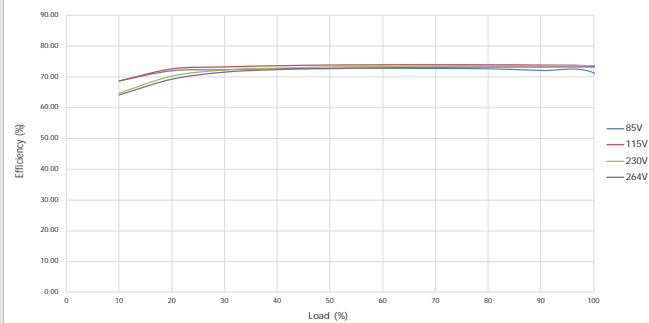

BAC10S05DC

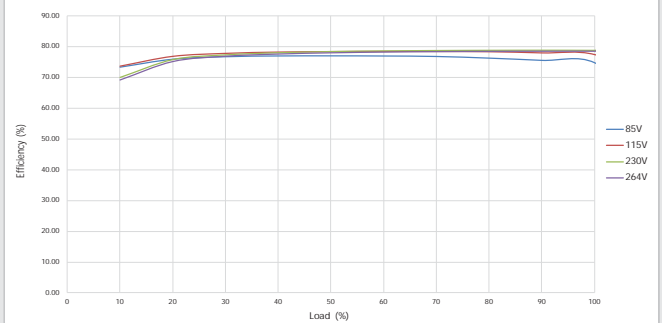

BAC10S12DC

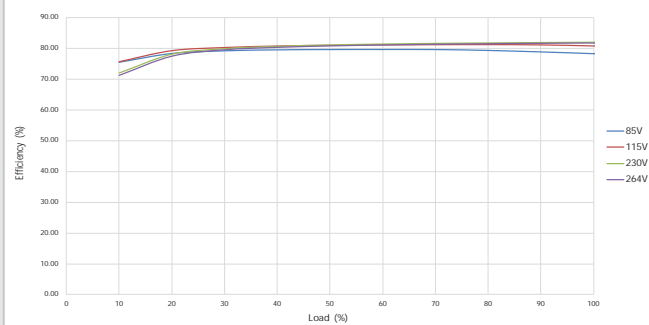

BAC10S24DC

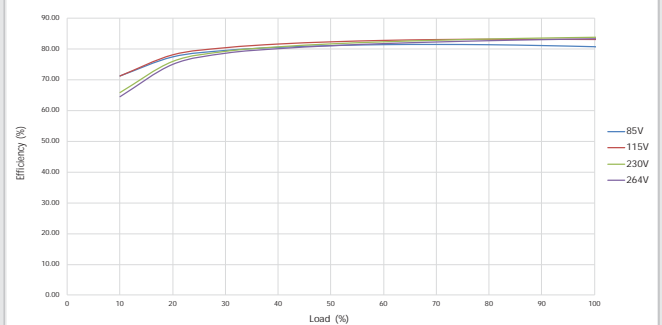

TEMPERATURE DERATING - OPERATIONAL

BAC10S03DC

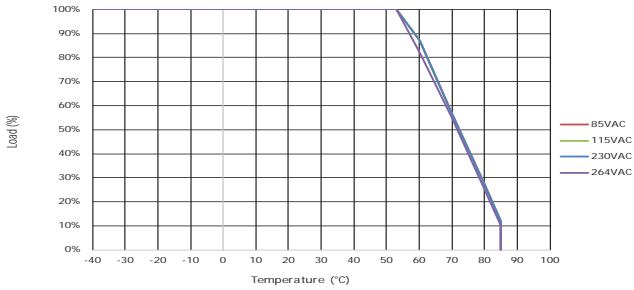

BAC10S05DC

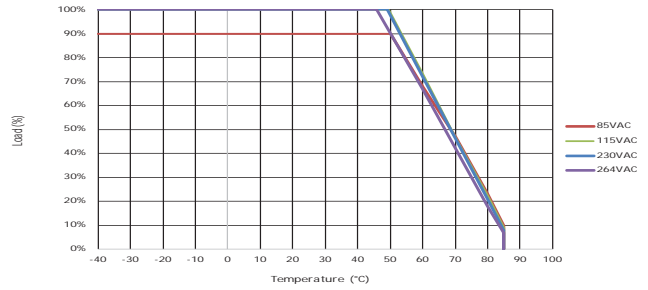

BAC10S12DC

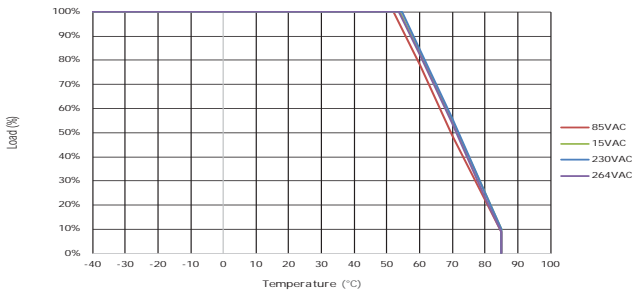

BAC10S24DC

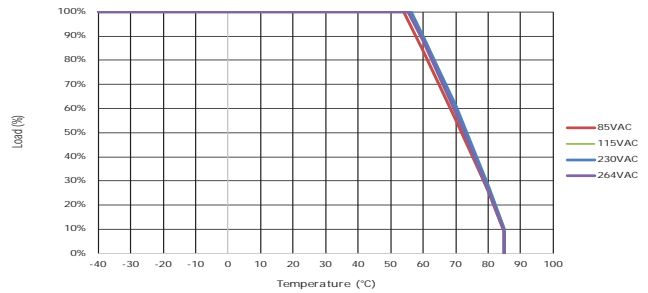

TEMPERATURE DERATING - COLD START

BAC10S03DC

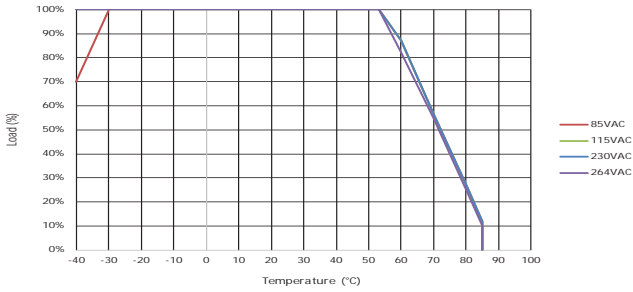

BAC10S05DC

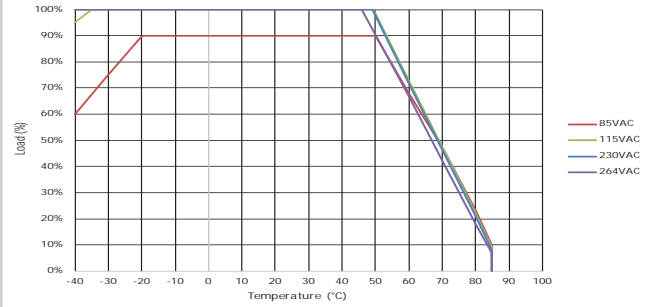

BAC10S12DC

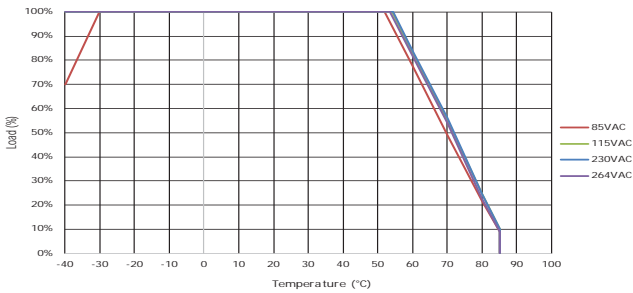

BAC10S24DC

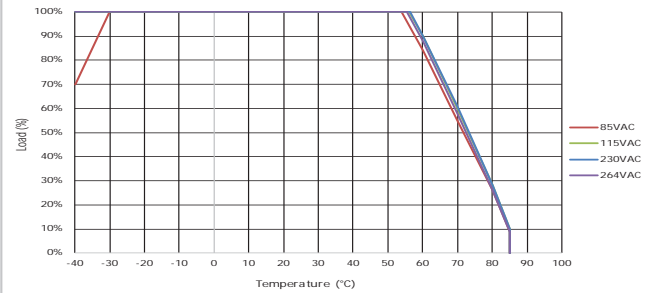

TEMPERATURE DERATING - 6 PIN VARIANTS

BAC10S03D6C

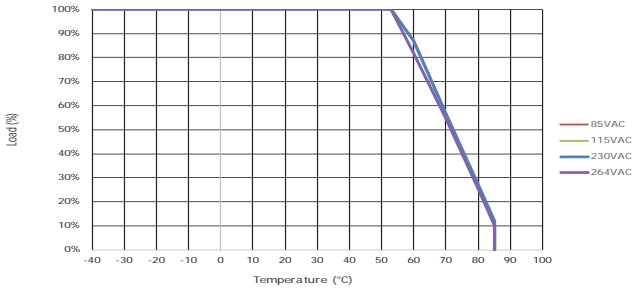

BAC10S05D6C

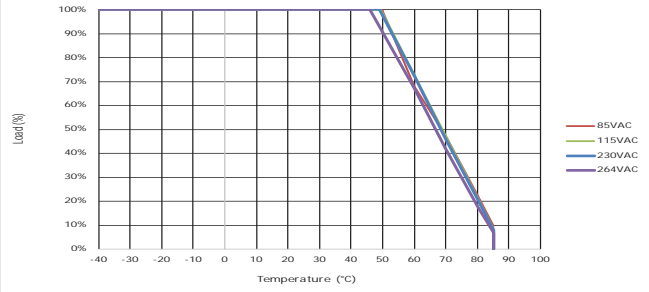

BAC10S12D6C

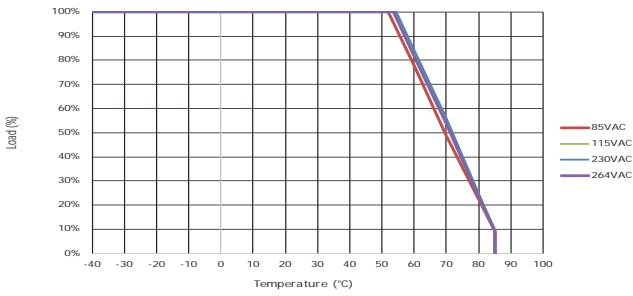

BAC10S24D6C

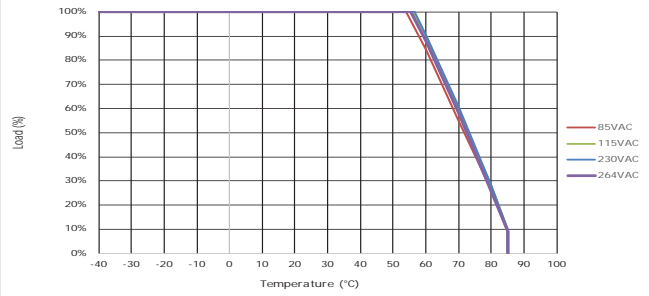

PACKAGE SPECIFICATIONS

MECHANICAL DIMENSIONS - STANDARD

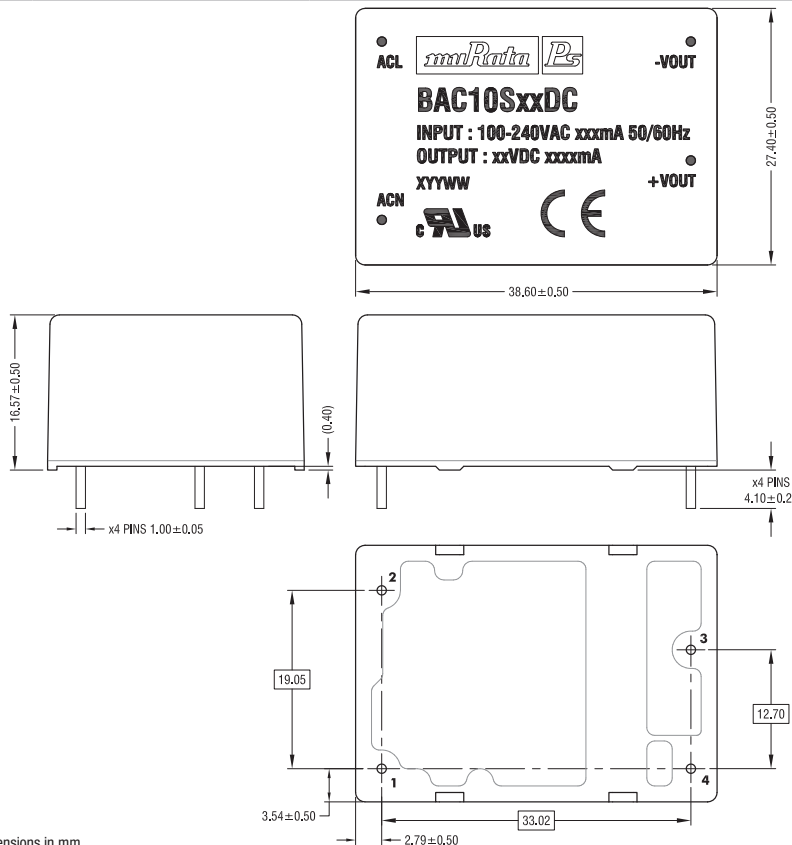

All dimensions in mm
Unless otherwise specified all pins within ±0.30 of true position.

Weight: 30g

PIN CONNECTIONS

Pin	Function
1	AC(L)
2	AC(N)
3	+Vout
4	-Vout

TUBE OUTLINE DIMENSIONS

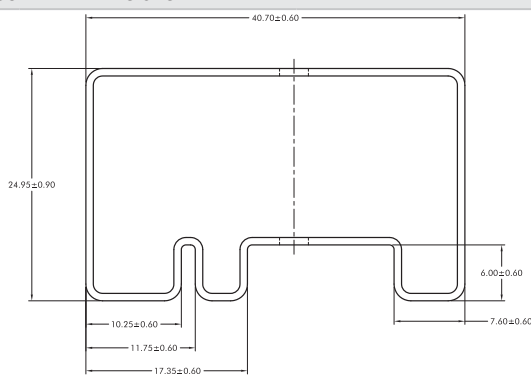

Unless otherwise specified all dimensions in mm.
Tube Length : 530mm±2.0

Tube Quantity : 18

RECOMMENDED FOOTPRINT DETAILS

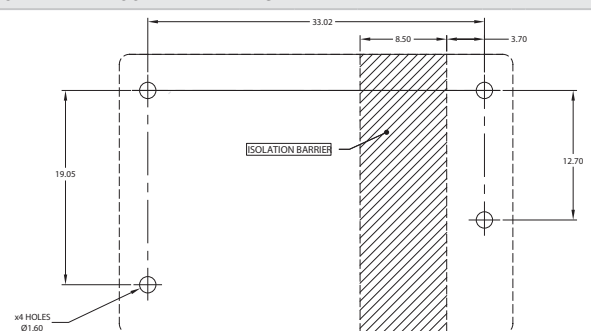

The isolation barrier shown must not have any copper traces even on internal layers. This is to avoid compromising the creepage and clearance distance. PCB layouts must take into consideration the required clearance and creepage requirements to maintain the clearance and creepage of the isolation barrier.
All dimensions in mm (inches).

PACKAGE SPECIFICATIONS

MECHANICAL DIMENSIONS - OPTIONAL 6 PIN

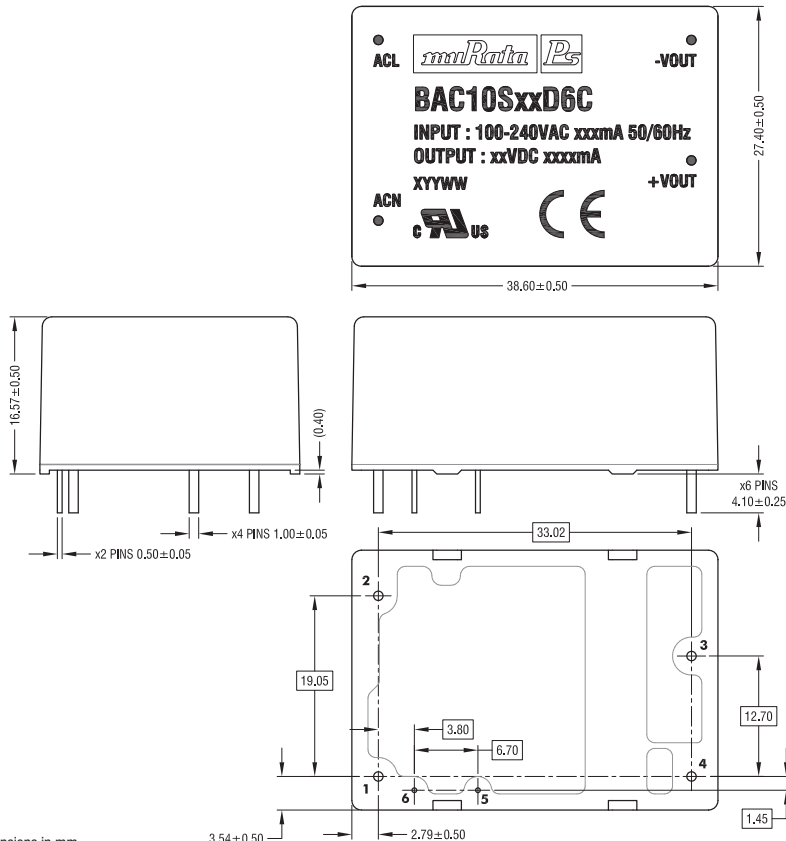

All dimensions in mm
Unless otherwise specified all pins within ± 0.30 of true position.

Weight: 30g

PIN CONNECTIONS

Pin	Function
1	AC(L)
2	AC(N)
3	+Vout
4	-Vout
5	-Cin
6	+Cin

TUBE OUTLINE DIMENSIONS

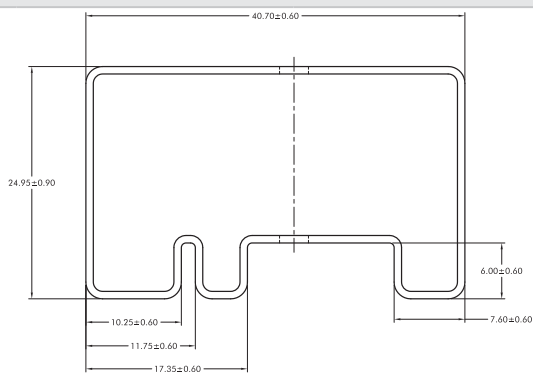

Unless otherwise specified all dimensions in mm.
Tube Length : 530mm ± 2.0

Tube Quantity : 18

RECOMMENDED FOOTPRINT DETAILS

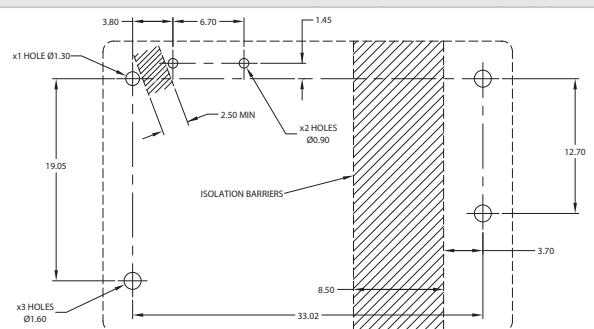

The isolation barrier shown must not have any copper traces even on internal layers. This is to avoid compromising the creepage and clearance distance. PCB layouts must take into consideration the required clearance and creepage requirements to maintain the clearance and creepage of the isolation barrier.
All dimensions in mm (inches).

DISCLAIMER

Unless otherwise stated in the datasheet, all products are designed for standard commercial and industrial applications and NOT for safety-critical and/or life-critical applications.

Particularly for safety-critical and/or life-critical applications, i.e. applications that may directly endanger or cause the loss of life, inflict bodily harm and/or loss or severe damage to equipment/property, and severely harm the environment, a prior explicit written approval from Murata is strictly required. Any use of Murata standard products for any safety-critical, life-critical or any related applications without any prior explicit written approval from Murata shall be deemed unauthorised use.

These applications include but are not limited to:

- Aircraft equipment
- Aerospace equipment
- Undersea equipment
- Power plant control equipment
- Medical equipment
- Transportation equipment (automobiles, trains, ships, etc.)
- Traffic signal equipment
- Disaster prevention / crime prevention equipment
- Data Processing equipment

Murata makes no express or implied warranty, representation, or guarantee of suitability, fitness for any particular use/purpose and/or compatibility with any application or device of the buyer, nor does Murata assume any liability whatsoever arising out of unauthorised use of any Murata product for the application of the buyer. The suitability, fitness for any particular use/purpose and/or compatibility of Murata product with any application or device of the buyer remain to be the responsibility and liability of the buyer.

Buyer represents and agrees that it has all the necessary expertise to create and implement safeguards that anticipate dangerous consequences of failures, monitor failures and their consequences, lessen the likelihood of failures that might cause harm, and take appropriate remedial actions. Buyer will fully indemnify and hold Murata, its affiliated companies, and its representatives harmless against any damages arising out of unauthorised use of any Murata products in any safety-critical and/or life-critical applications.

Remark: Murata in this section refers to Murata Manufacturing Company and its affiliated companies worldwide including, but not limited to, Murata Power Solutions.



This product is subject to the following [operating requirements](https://www.murata.com/en-eu/products/power/requirements) and the [Life and Safety Critical Application Sales Policy](https://www.murata.com/en-eu/products/power/requirements):

Refer to: <https://www.murata.com/en-eu/products/power/requirements>

Murata Power Solutions (Milton Keynes) Ltd. makes no representation that the use of its products in the circuits described herein, or the use of other technical information contained herein, will not infringe upon existing or future patent rights. The descriptions contained herein do not imply the granting of licenses to make, use, or sell equipment constructed in accordance therewith. Specifications are subject to change without notice.
© 2025 Murata Power Solutions (Milton Keynes) Ltd.