



FEATURES

- Measure and accurately display dc voltages in harsh environments
- Four input ranges: $\pm 200\text{mVdc}$, $\pm 2\text{Vdc}$, $\pm 20\text{Vdc}$, and $\pm 200\text{Vdc}$
- Daylight-readable LED display with automatic brightness adjustment
- Moisture & impact resistant package offers NEMA-4/IP65 protection
- Operates from universal 85-264Vac mains, or 110-300Vdc supplies
- Input circuit fully isolated from ac power supply

Murata Power Solutions' DMU-30DCV series of daylight-readable dc voltmeters measure and display dc signals as low as $\pm 200\text{mV}$ and as high as $\pm 200\text{V}$. Their large 0.56" (14.2mm) high super-bright red LED-display is readable in full sunlight. An auto-dimming circuit automatically adjusts the display brightness for all viewing conditions.

DMU-30DCV series dc voltmeters are packaged in a rugged, one-piece polycarbonate plastic housing that features an integrated bezel and gasket assembly. In a typical installation, the housing is secured to a panel with six metallic threaded inserts, allowing the unit to meet NEMA-4 / IP65 requirements for moisture and impact resistance in outdoor applications.

DMU-30DCV series dc voltmeters are available in a choice of four input ranges: $\pm 200\text{mVdc}$ (with 0.1mV resolution); $\pm 2\text{Vdc}$ (0.001V resolution); $\pm 20\text{Vdc}$ (0.01V resolution); and $\pm 200\text{Vdc}$ (0.1V resolution). The dc signal under measurement is electrically isolated from the unit's operating power source.

DMU-30DCV series' miniature size and rugged package are perfect for industrial and high-reliability instrumentation, alternative power generators, and any other application which requires daylight readability and precise monitoring of dc voltages in harsh indoor / outdoor environments. Simply connect the input signal and an 85-264Vac source of operating power to the two rear-mounted terminal blocks and the unit is fully operational.

TECHNICAL NOTES

IMPORTANT! To ensure safe and reliable operation, DMU-30DCV dc voltmeters must be installed and serviced by qualified technical personnel. Contact Murata Power Solutions if there is any doubt regarding installation and/or operation.

- 1. Measurement Type:** All DMU-30DCV series dc voltmeters achieve their excellent performance by employing a precision integrating analog-to-digital converter, metal film resistor dividers, and a high-stability voltage reference IC. The LED display is updated approximately 2.5 to 3 times per second. However, while some input filtering is provided, noisy signals may cause the displayed reading to vary by a few counts.
- 2. Wiring:** All ac supply (TB1) and input signal (TB2) wiring must be adequately rated for the voltages and currents they will carry, and must comply with any code or application-mandated requirements pertaining to the user's specific installation.
- 3. Power Supply Polarity, Fusing, Wiring and Grounding:** The power supply inputs (TB1-1 and TB1-2) on DMU-30DCV voltmeters are not polarity sensitive, that is, they have no "AC LO" or "AC HI" designations. These units do not include or require a connection to earth/chassis ground. Refer to Figure 1 for a typical wiring diagram.

Wires specified in the Functional Specifications section must be used for making connections to DMU-30DCV series voltmeters. All power-supply and load wiring must be rated for the supply voltages and currents they will conduct and must comply with any code or application-mandated requirements pertaining to the user's specific installation.

DMU-30DCV voltmeters are not internally fused. Terminal block TB1 is to be used only for powering the power meter's internal circuitry; it must not be used to supply power to external loads. The supply wires feeding these power meters must be fused with a 0.5A/250V time delay/time lag fuse, in accordance with applicable regulatory codes.

Wire insulation must be stripped to within $\pm 10\%$ of the stated dimensions, and wires should be inserted into TB1 such that their insulation is not pinched by the screw terminal.

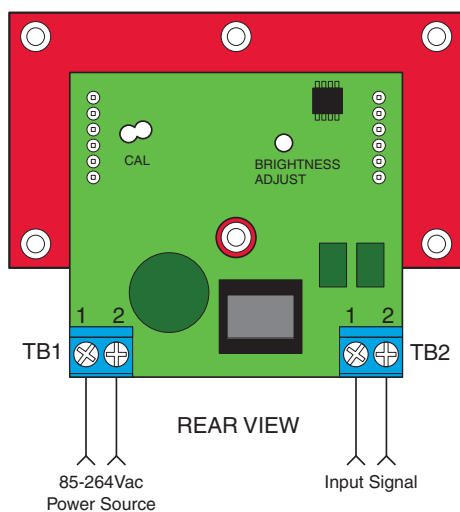

Figure 1. DMU-30DCV wiring diagram



TECHNICAL NOTES (continued)

4. Calibration: Periodic recalibration of DMU-30DCV voltmeters is not required under normal indoor operating environments. However, operation in environments subject to vibration and/or extreme temperature variations should have their accuracy verified on a yearly basis. If recalibration is necessary, it should only be performed by qualified technical personnel. Calibration is performed with potentially lethal voltages applied to the DMU-30DCV and its associated wiring. A plastic, fully-insulated adjusting tool must be used to access the recessed calibration potentiometer located on the back of the unit (see Mechanical Specifications). Contact Murata Power Solutions if additional information is required regarding calibration, setup, or any other technical issue pertaining to DMU-30DCV dc voltmeters.

5. Minimum-Intensity Adjustment Potentiometer: Users can adjust the DMU-30DCV's minimum LED display brightness to suit their indoor viewing requirements by adjusting the ¼-turn, rear-mounted intensity adjustment potentiometer. Please note, this potentiometer will have minimal impact on display brightness in high ambient light environments.

The intensity adjustment potentiometer is factory preset to its mid-point position. As viewed from the rear of the meter, and with the model number label facing up, turning the potentiometer clockwise increases the LED display's intensity. See the Mechanical Specifications section for potentiometer locations.

6. Operation with Power Supplies Lower than 85Vac: In indoor applications where daylight readability (i.e., maximum display brightness) is not required, DMU-30DCV meters will meet their specified accuracy with ac supply voltages (TB1) well below 85Vac. While performance is not guaranteed, DMU-30DCV voltmeters remain easily readable and accurate with ac supplies as low as 20Vac.

7. Panel Installation: All electrical connections to DMU-30DCV must be made after the meter is securely attached to the panel and with all input and supply voltages de-energized (off). Care must be exercised when attaching conductors to terminal blocks TB1 and TB2. The installed wire-positions should be such that minimal forces are applied to the terminal blocks or the voltmeter. In high-vibration environments, adequate strain reliefs must be used on all input and supply wiring.

To ensure a secure and moisture/vibration resistant installation, use only the supplied hardware. Following the four-step sequence shown—being careful not to apply excessive force or twisting motions—insert the voltmeter into the panel opening. Tighten all six M3 metric screws to 3 inch-pounds (0.34Nm). See the Mechanical Specifications section for panel cutout, drill dimensions, and panel installation information.

Performance/Functional Specifications

Typical at T_A = +25°C, unless otherwise noted.

Input (TB2)	Min.	Typ.	Max.	Units
Full Scale Input Range:				
DMU-30DCV-0-DR-C	0	–	199.9	mVdc
DMU-30DCV-1-DR-C	0	–	1.999	Vdc
DMU-30DCV-2-DR-C	0	–	19.99	Vdc
DMU-30DCV-3-DR-C	0	–	199.9	Vdc
Performance				
Sampling Rate	2.5 readings per second			
Accuracy	±0.4%FS ±2 counts			
Zero Reading (within 30 sec.)	“-001”	“000”	“001”	Cnts
Temperature Drift (0 to +60°C)	–	±0.2	±0.4	Cnts/°C
Breakdown Voltage (TB1 to TB2)	2000	–	–	Vdc
Supply Voltage (TB1)				
DMU-30DCV	85	–	264	Vac/47-63Hz
Supply Current (TB1) ①				
DMU-30DCV (total darkness)	–	4	6	mA/47-63Hz
DMU-30DCV (full sunlight)	–	40	50	mA/47-63Hz
Terminal Block Wiring (TB1 & TB2)				
Wire Size	16-22 AWG, Solid or stranded			
Insulation Strip Length	0.250 inches (6.35)			
Screw Tightening Torque	2.2 lb-in (0.25 N·m) ±20%			
Rated Voltage	300Vac			
Display				
Display Type and Size	Daylight readable, auto-dimming, 3½ digit, 0.56"/14.2mm high red LED			
Decimal Point	Fixed, model dependent			
Overrange Indication	"1_ _ _"			
Physical/Environmental				
Operating Temperature	–25	–	+60	°C
Storage Temperature	–40	–	+75	°C
Humidity (non-condensing)	0	–	85	%
Dimensions	See mechanical specifications			
Weight	1.3 ounces (36 grams) nominal			

① Display reading is set to "1888". Specified power supply currents are steady state; larger surge currents can occur at initial application of ac power. Power supply input (TB1) set to 120Vac/60 Hz.

Ordering Information

Model	Input Range
DMU-30DCV-0-DR-C	0 to ±199.9mVdc
DMU-30DCV-1-DR-C	0 to ±1.999Vdc * To Be Discontinued
DMU-30DCV-2-DR-C	0 to ±19.99Vdc * To Be Discontinued
DMU-30DCV-3-DR-C	0 to ±199.9Vdc * To Be Discontinued

See www.murata-ps.com/dpm-availability for model-specific availability.

Ruggedized DC Voltmeters with Daylight Readable Auto-Dimming LED Displays

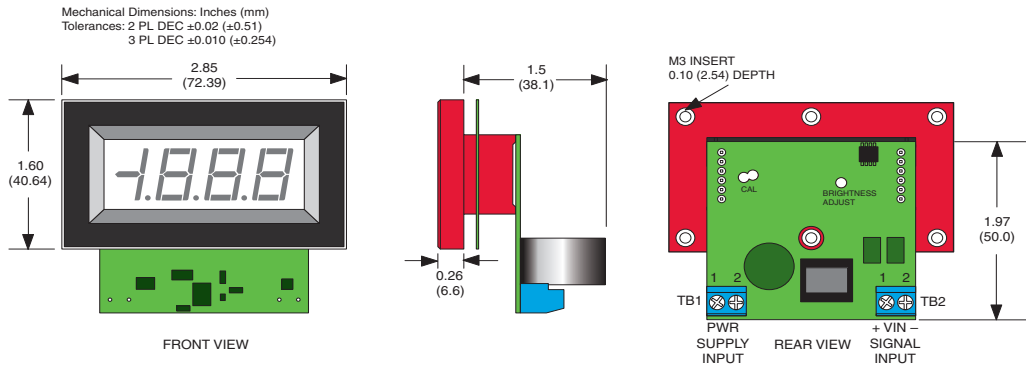

RECOMMENDED DRILL AND PANEL CUTOUT

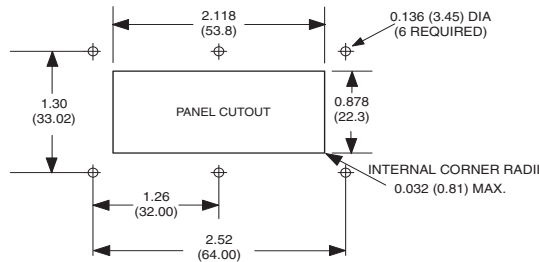

Note: The supplied M3 screws and washers will accommodate panel thicknesses from 0.060 to 0.090 inches (1.52 to 2.28 mm).

Tighten screws to 3.5–4.5 in-lbs (0.4–0.5 Nm).

PANEL INSTALLATION

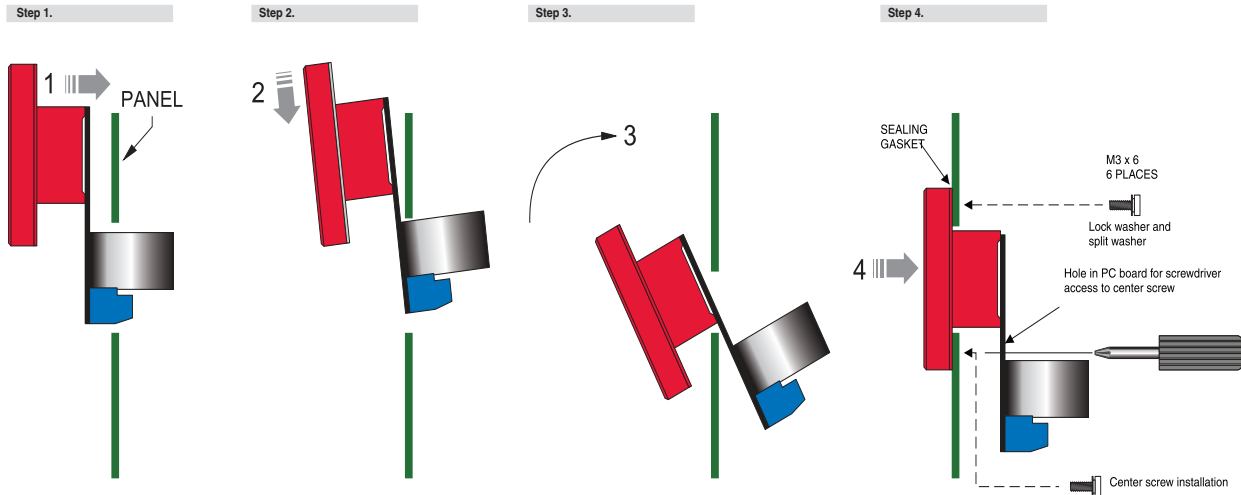

Murata Power Solutions, Inc.
129 Flanders Rd. Westborough, Ma 01581, USA.
ISO 9001 and 14001 REGISTERED



This product is subject to the following operating requirements and the Life and Safety Critical Application Sales Policy:
Refer to: <https://www.murata-ps.com/requirements/>

Murata Power Solutions, Inc. makes no representation that the use of its products in the circuits described herein, or the use of other technical information contained herein, will not infringe upon existing or future patent rights. The descriptions contained herein do not imply the granting of licenses to make, use, or sell equipment constructed in accordance therewith. Specifications are subject to change without notice.
© 2021 Murata Power Solutions, Inc.